

DATA SHEET

For a complete data sheet, please also download:

- The IC04 LOCMOS HE4000B Logic Family Specifications HEF, HEC
- The IC04 LOCMOS HE4000B Logic Package Outlines/Information HEF, HEC

HEF40195B

MSI

4-bit universal shift register

Product specification
File under Integrated Circuits, IC04

January 1995

4-bit universal shift register

HEF40195B MSI

DESCRIPTION

The HEF40195B is a fully synchronous edge-triggered 4-bit shift register with a clock input (CP), four synchronous parallel data inputs (P_0 to P_3), two synchronous serial data inputs (J, \bar{K}), a synchronous parallel enable input (\overline{PE}), buffered parallel outputs from all 4-bit positions (O_0 to O_3), a buffered inverted output from the last bit position (\bar{O}_3) and an overriding asynchronous master reset input (\overline{MR}). Each register stage is of a D-type master-slave flip-flop. Operation is synchronous (except for \overline{MR}) and is edge-triggered on the LOW to HIGH transition of the CP

input. When \overline{PE} is LOW, data are loaded into the register from P_0 to P_3 on the LOW to HIGH transition of CP. When \overline{PE} is HIGH, data are shifted into the first register position from J and \bar{K} and all the data in the register are shifted one position to the right on the LOW to HIGH transition of CP. D-type entry is obtained by interconnecting J and \bar{K} . When J is HIGH and \bar{K} is LOW, the first stage is in the toggle mode. When J is LOW and \bar{K} is HIGH, the first stage is in the hold mode. A LOW on \overline{MR} resets all four bit positions (O_0 to $O_3 = \text{LOW}$, $\bar{O}_3 = \text{HIGH}$) independent of all other input conditions.

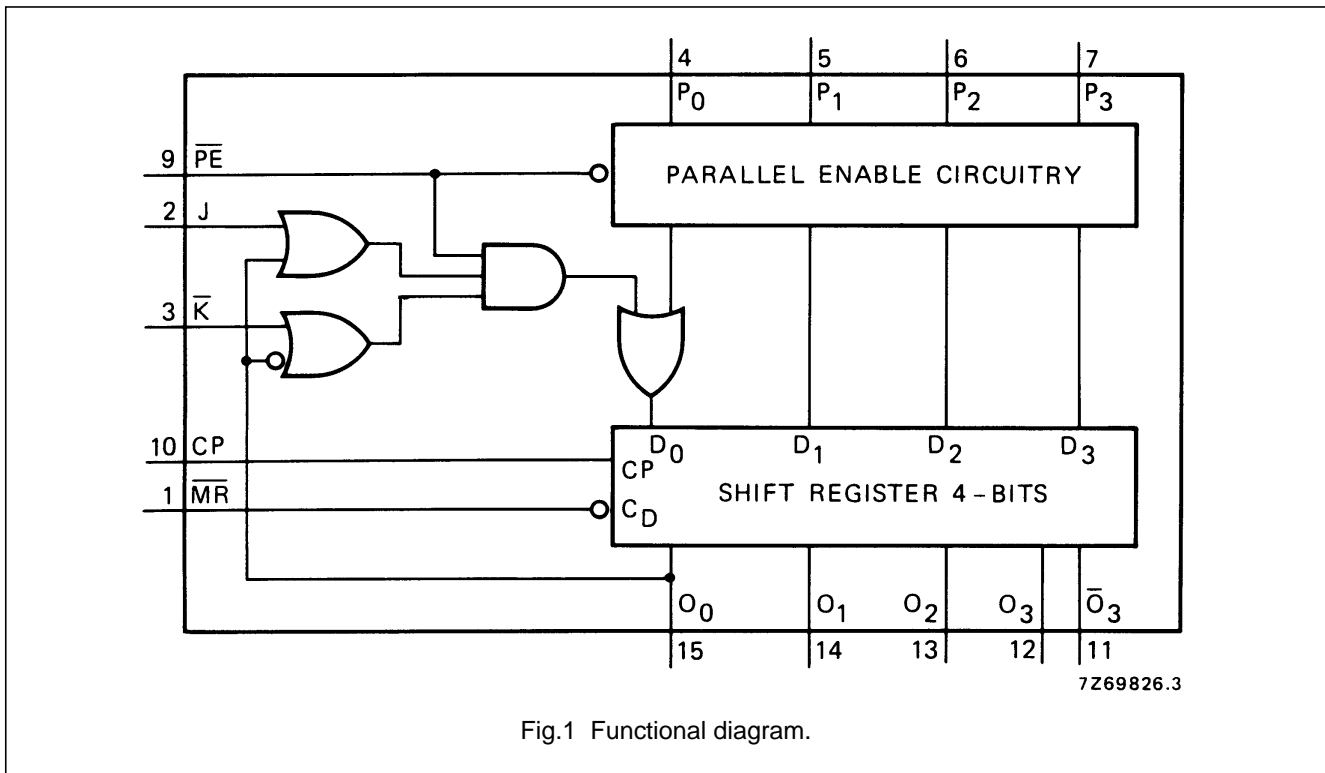

Fig.1 Functional diagram.

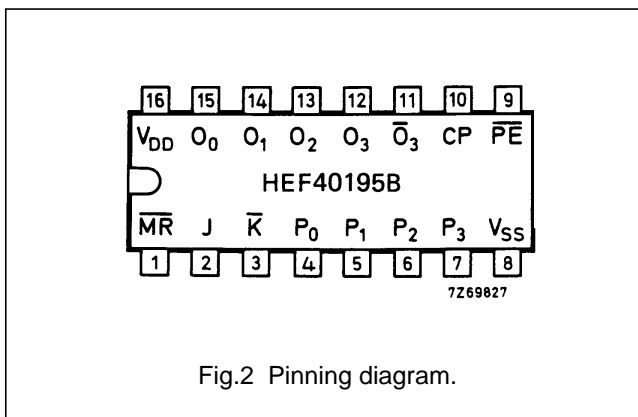

Fig.2 Pinning diagram.

- HEF40195BP(N): 16-lead DIL; plastic (SOT38-1)
 - HEF40195BD(F): 16-lead DIL; ceramic (cerdip) (SOT74)
 - HEF40195BT(D): 16-lead SO; plastic (SOT109-1)
- (): Package Designator North America

FAMILY DATA, I_{DD} LIMITS category MSI

See Family Specifications

4-bit universal shift register

HEF40195B
MSI

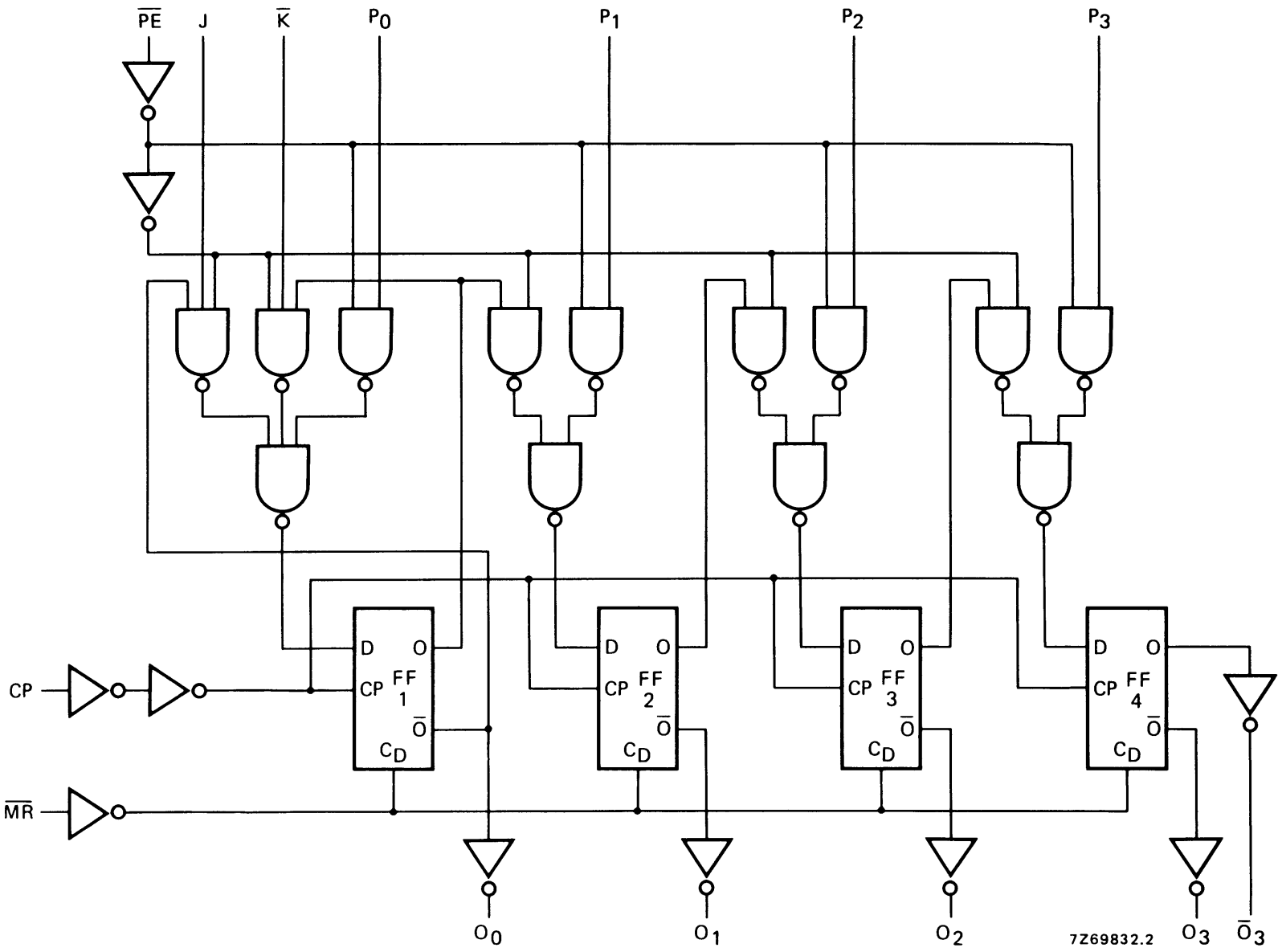

Fig.3 Logic diagram.

4-bit universal shift register

HEF40195B
MSI

PINNING

\overline{PE}	parallel enable input (active LOW)
P_0 to P_3	parallel data inputs
J	first stage J-input (active HIGH)
\overline{K}	first stage K-input (active LOW)
CP	clock input (LOW to HIGH edge triggered)
\overline{MR}	master reset input (active LOW)
O_0 to O_3	buffered parallel outputs
\overline{O}_3	buffered inverted output from last stage

FUNCTION TABLE

OPERATING MODE	INPUTS ($\overline{MR} = \text{HIGH}$)							OUTPUTS AT t_{n+1}				
	\overline{PE}	J	\overline{K}	P_0	P_1	P_2	P_3	O_0	O_1	O_2	O_3	\overline{O}_3
shift mode	H	L	L	X	X	X	X	L	O_0	O_1	O_2	\overline{O}_2
	H	L	H	X	X	X	X	O_0	O_0	O_1	O_2	\overline{O}_2
	H	H	L	X	X	X	X	\overline{O}_0	O_0	O_1	O_2	\overline{O}_2
	H	H	H	X	X	X	X	H	O_0	O_1	O_2	\overline{O}_2
parallel entry mode	L	X	X	L	L	L	L	L	L	L	L	H
	L	X	X	H	H	H	H	H	H	H	H	L

Notes

1. H = HIGH state (the more positive voltage)
2. L = LOW state (the less positive voltage)
3. X = state is immaterial
4. t_{n+1} = state after next LOW to HIGH transition of CP

4-bit universal shift register

HEF40195B
MSI**AC CHARACTERISTICS** $V_{SS} = 0\text{ V}$; $T_{amb} = 25\text{ °C}$; $C_L = 50\text{ pF}$; input transition times $\leq 20\text{ ns}$

	V_{DD} V	SYMBOL	MIN.	TYP.	MAX.	TYPICAL EXTRAPOLATION FORMULA		
Propagation delays $CP \rightarrow O_n$ HIGH to LOW	5	t_{PHL}		105	215	ns	$78\text{ ns} + (0,55\text{ ns/pF}) C_L$	
	10			50	95	ns	$39\text{ ns} + (0,23\text{ ns/pF}) C_L$	
	15			35	65	ns	$27\text{ ns} + (0,16\text{ ns/pF}) C_L$	
	LOW to HIGH	5	t_{PLH}		90	180	ns	$63\text{ ns} + (0,55\text{ ns/pF}) C_L$
		10			45	85	ns	$34\text{ ns} + (0,23\text{ ns/pF}) C_L$
		15			30	60	ns	$22\text{ ns} + (0,16\text{ ns/pF}) C_L$
$CP \rightarrow \overline{O}_3$ HIGH to LOW	5	t_{PHL}		125	255	ns	$98\text{ ns} + (0,55\text{ ns/pF}) C_L$	
	10			50	100	ns	$39\text{ ns} + (0,23\text{ ns/pF}) C_L$	
	15			35	70	ns	$27\text{ ns} + (0,16\text{ ns/pF}) C_L$	
	LOW to HIGH	5	t_{PLH}		120	240	ns	$93\text{ ns} + (0,55\text{ ns/pF}) C_L$
		10			50	105	ns	$39\text{ ns} + (0,23\text{ ns/pF}) C_L$
		15			35	75	ns	$27\text{ ns} + (0,16\text{ ns/pF}) C_L$
$\overline{MR} \rightarrow O_n$ HIGH to LOW	5	t_{PHL}		100	205	ns	$73\text{ ns} + (0,55\text{ ns/pF}) C_L$	
	10			45	90	ns	$34\text{ ns} + (0,23\text{ ns/pF}) C_L$	
	15			30	65	ns	$22\text{ ns} + (0,16\text{ ns/pF}) C_L$	
	LOW to HIGH	5	t_{PLH}		125	235	ns	$98\text{ ns} + (0,55\text{ ns/pF}) C_L$
		10			55	115	ns	$44\text{ ns} + (0,23\text{ ns/pF}) C_L$
		15			40	85	ns	$32\text{ ns} + (0,16\text{ ns/pF}) C_L$
Output transition times	5	t_{THL}		60	120	ns	$10\text{ ns} + (1,0\text{ ns/pF}) C_L$	
	10			30	60	ns	$9\text{ ns} + (0,42\text{ ns/pF}) C_L$	
	15			20	40	ns	$6\text{ ns} + (0,28\text{ ns/pF}) C_L$	
	LOW to HIGH	5	t_{TLH}		60	120	ns	$10\text{ ns} + (1,0\text{ ns/pF}) C_L$
		10			30	60	ns	$9\text{ ns} + (0,42\text{ ns/pF}) C_L$
		15			20	40	ns	$6\text{ ns} + (0,28\text{ ns/pF}) C_L$

4-bit universal shift register

HEF40195B
MSI**AC CHARACTERISTICS** $V_{SS} = 0$ V; $T_{amb} = 25$ °C; $C_L = 50$ pF; input transition times ≤ 20 ns

	V_{DD} V	SYMBOL	MIN.	TYP.	MAX.	
Set-up times $J, \bar{K} \rightarrow CP$ $P_n \rightarrow CP$ $\bar{PE} \rightarrow CP$	5	t_{su}	70	35	ns	see also waveforms Figs 4 and 5
	10		20	10	ns	
	15		10	5	ns	
	5	t_{su}	85	40	ns	
	10		25	10	ns	
	15		10	5	ns	
	5	t_{su}	115	55	ns	
	10		45	20	ns	
	15		30	15	ns	
Hold times $J, \bar{K} \rightarrow CP$ $P_n \rightarrow CP$ $\bar{PE} \rightarrow CP$	5	t_{hold}	15	-20	ns	
	10		5	-5	ns	
	15		0	-5	ns	
	5	t_{hold}	20	-25	ns	
	10		10	-5	ns	
	15		0	-5	ns	
	5	t_{hold}	10	-50	ns	
	10		5	-20	ns	
	15		5	-10	ns	
Minimum clock pulse width; LOW	5	t_{WCPL}	60	30	ns	
	10		25	10	ns	
	15		20	10	ns	
Minimum \bar{MR} pulse width; HIGH	5	t_{WMRL}	100	50	ns	
	10		40	20	ns	
	15		30	15	ns	
Recovery time for \bar{MR}	5	t_{RMR}	30	10	ns	
	10		15	5	ns	
	15		15	5	ns	
Maximum clock pulse frequency	5	f_{max}	5	10	MHz	
	10		14	28	MHz	
	15		19	39	MHz	

4-bit universal shift register

HEF40195B
MSI

	V _{DD} V	TYPICAL FORMULA FOR P (μW)	
Dynamic power dissipation per package (P)	5	$1900 f_i + \sum (f_o C_L) \times V_{DD}^2$	where f _i = input freq. (MHz) f _o = output freq. (MHz) C _L = load capacitance (pF) ∑ (f _o C _L) = sum of outputs V _{DD} = supply voltage (V)
	10	$8300 f_i + \sum (f_o C_L) \times V_{DD}^2$	
	15	$22\ 800 f_i + \sum (f_o C_L) \times V_{DD}^2$	

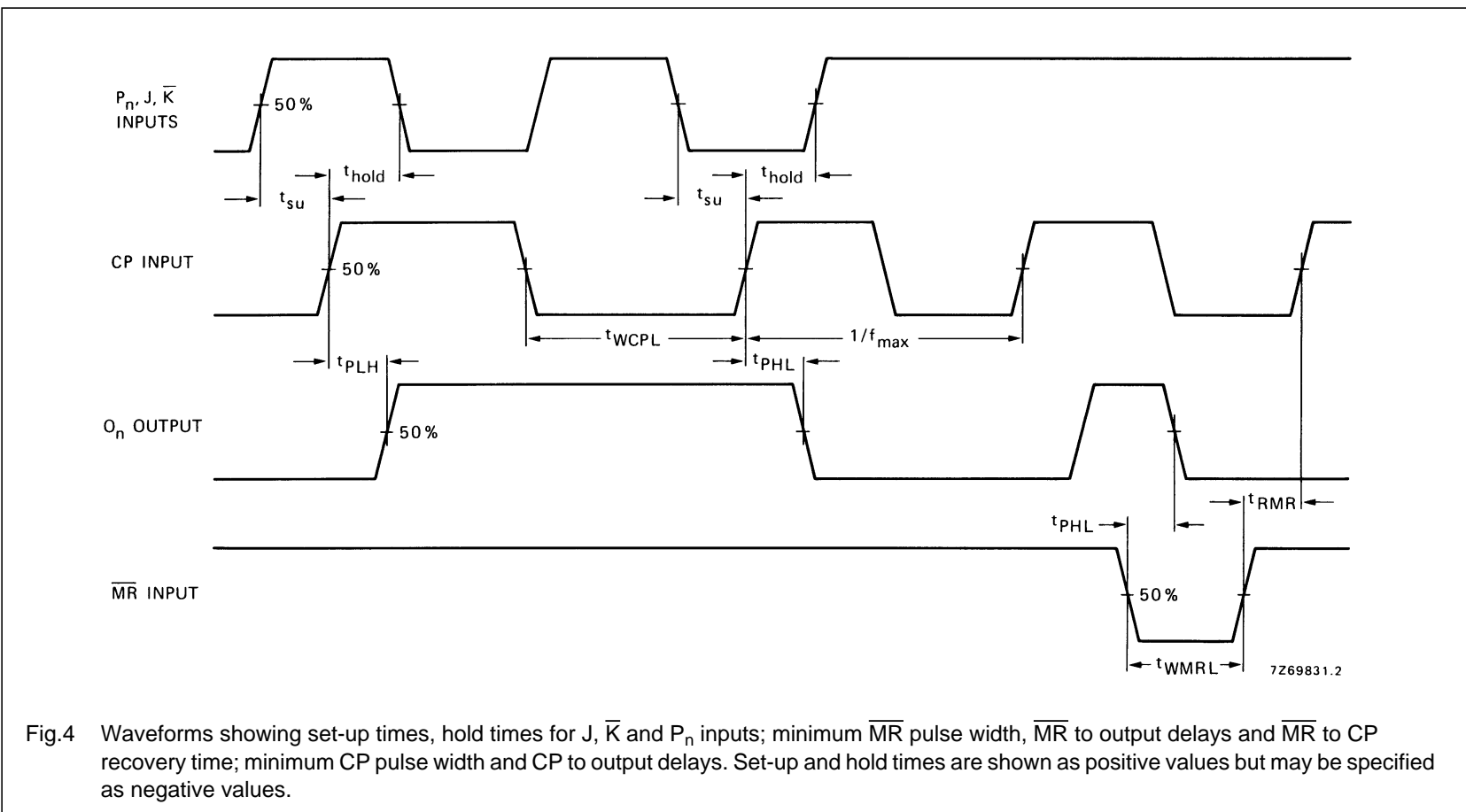

Fig.4 Waveforms showing set-up times, hold times for J, K̄ and P_n inputs; minimum MR pulse width, MR to output delays and MR to CP recovery time; minimum CP pulse width and CP to output delays. Set-up and hold times are shown as positive values but may be specified as negative values.

4-bit universal shift register

HEF40195B
MSI

Fig.5 Waveforms showing set-up and hold times for \overline{PE} input. Set-up and hold times are shown as positive values but may be specified as negative values.

APPLICATION INFORMATION

Some examples of applications for the HEF40195B are:

- Serial data transfer
- Parallel data transfer
- Serial to parallel data transfer
- Parallel to serial data transfer

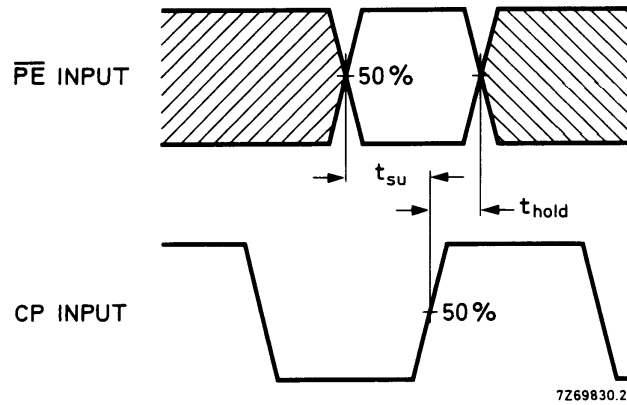

LittleDiode supplies new, hard to find or obsolete electronic components and semiconductors all over the world.

With over two million different components listed you are sure to find the part you need.

Feel free to visit us today at our online store:

LittleDiode.com

Looking forward to providing you with the best possible service.