

# DATA SHEET

For a complete data sheet, please also download:

- The IC04 LOCMOS HE4000B Logic Family Specifications HEF, HEC
- The IC04 LOCMOS HE4000B Logic Package Outlines/Information HEF, HEC

**HEF4720B**

**HEF4720V**

**LSI**

**256-bit, 1-bit per word random access memories**

Product specification  
File under Integrated Circuits, IC04

January 1995

256-bit, 1-bit per word random access memories

HEF4720B  
HEF4720V

DESCRIPTION

The HEF4720B and HEF4720V are 256-bit, 1-bit per word random access memories with 3-state outputs. The memories are fully decoded and completely static.

Recommended supply voltage range for HEF4720B is 3 to 15 V and for HEF4720V is 4,5 to 12,5 V; minimum stand-by voltage for both types is 3 V.

The use of LOC MOS gives the added advantage of very low stand-by power. The circuits can be directly interfaced with standard bipolar devices (TTL) without using special

interface circuits. The memory operates from a single power supply. The separate chip select input ( $\overline{CS}$ ) allows simple memory expansion when the outputs are wire-ORed. If  $\overline{CS}$  is HIGH, the outputs are floating and no new information can be written into the memory. The signal at  $\overline{O}$  has the same polarity as the data input D, while the signal at  $\overline{O}$  is the complement of the signal at O. The write control W must be HIGH for writing into the memory.

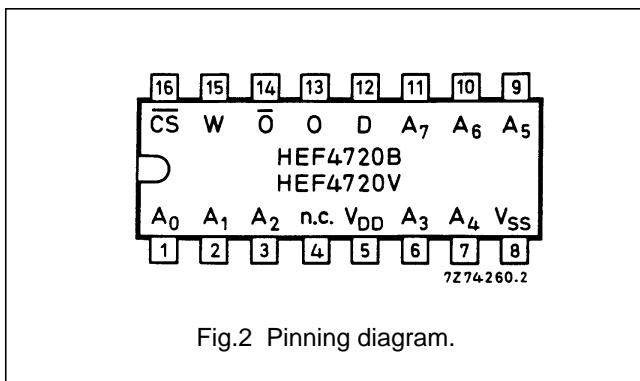
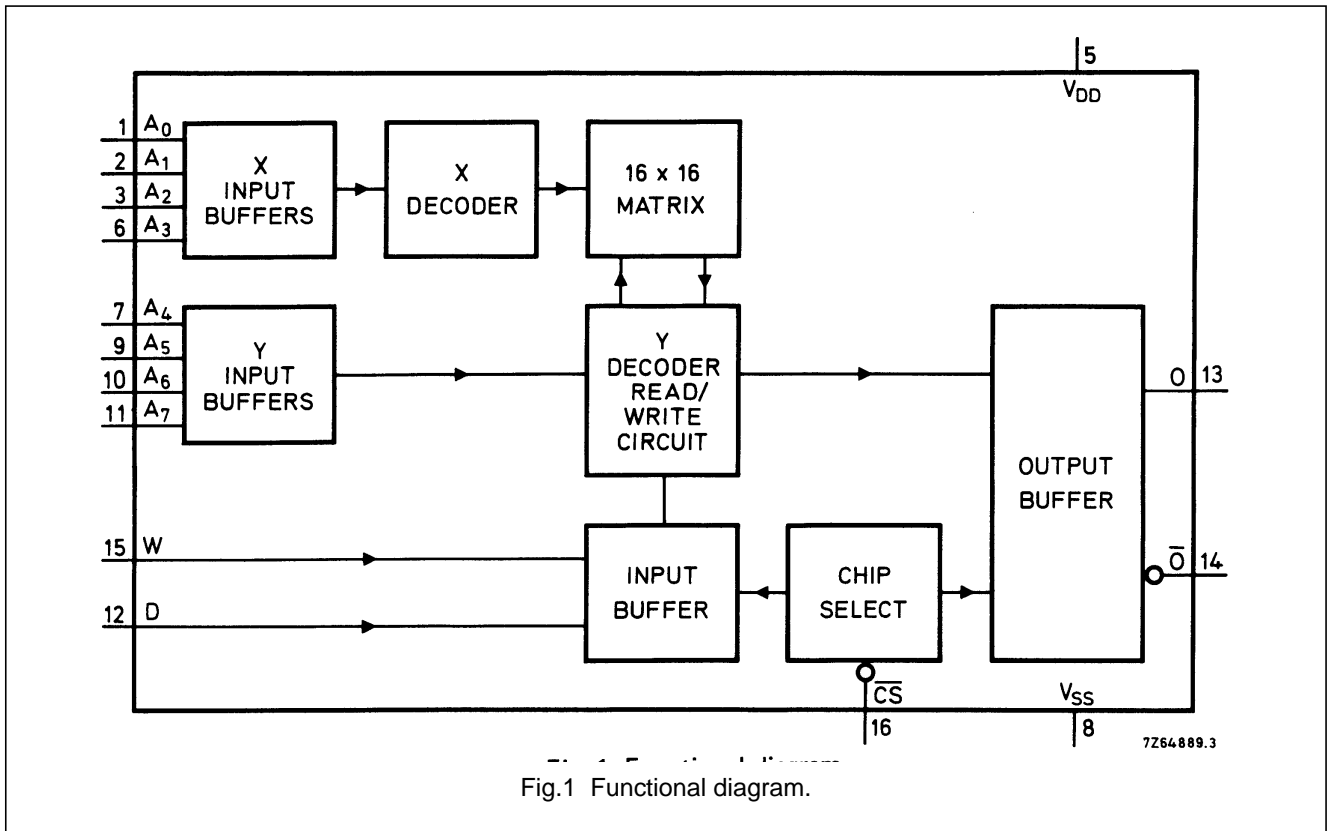

- HEF4720BP; HEF4720VP(N): 16-lead DIL; plastic (SOT38-1)
- HEF4720BD; HEF4720VD(F): 16-lead DIL; ceramic (cerdip) (SOT74)
- HEF4720BT; HEF4720VT(D): 16-lead SO; plastic (SOT109-1)

( ): Package Designator North America

FAMILY DATA

See Family Specifications.

## 256-bit, 1-bit per word random access memories

HEF4720B  
HEF4720V**I<sub>DD</sub> LIMITS**

See below.

**FUNCTION TABLE**

$\overline{\text{CS}}$	W	O	$\overline{\text{O}}$	MODE
L	H	data written into memory	complement of data written into memory	write
L	L	data written into memory	complement of data written into memory	read
H	X	Z	Z	inhibit

**PINNING**

$\overline{\text{CS}}$	chip select input (active LOW)
W	write enable input
D	data input
A <sub>0</sub> to A <sub>7</sub>	address inputs
O	3-state output (active HIGH)
$\overline{\text{O}}$	3-state output (active LOW)

**Notes**

- H = HIGH state (the more positive voltage)  
L = LOW state (the less positive voltage)  
X = state is immaterial  
Z = high impedance OFF-state

**SUPPLY VOLTAGE**

	RATING	RECOMMENDED OPERATING	STAND-BY MIN.
HEF4720B	-0,5 to 18	3,0 to 15,0	3 V
HEF4720V	-0,5 to 18	4,5 to 12,5	3 V

The values given at V<sub>DD</sub> = 15 V in the following DC and AC characteristics, are not applicable to the HEF4720V, because of its lower supply voltage range.

**DC CHARACTERISTICS**V<sub>SS</sub> = 0 V

	V <sub>DD</sub> V	V <sub>OL</sub> V	SYMBOL	T <sub>amb</sub> (°C)					
				-40		+25		+85	
				MIN.	MAX.	MIN.	MAX.	MIN.	MAX.
Output current LOW	4,75	0,4	I <sub>OL</sub>	2,4	2	1,6	mA		
	10	0,5		4,8	4	3,2	mA		
	15	1,5		10,0	10	7,5	mA		
Quiescent device current	5		I <sub>DD</sub>	25	25	200 μA			
	10			50	50	400 μA			
	15			100	100	800 μA			
Input leakage current HEF4720V	10		±I <sub>IN</sub>	0,3	0,3	1 μA			
	HEF4720B	15		0,3	0,3	1 μA			

## 256-bit, 1-bit per word random access memories

HEF4720B  
HEF4720V

## AC CHARACTERISTICS

	V <sub>DD</sub> V	SYMBOL	MIN.	TYP.	MAX.		
Output capacitance	5	C <sub>O</sub>		5		pF	
	10		5		pF		
	15		5		pF		

## A.C. CHARACTERISTICS

V<sub>SS</sub> = 0 V; T<sub>amb</sub> = 25 °C; C<sub>L</sub> = 50 pF; input transition times ≤ 20 ns

	V <sub>DD</sub> V	SYMBOL	MIN.	TYP.	MAX.		TYPICAL EXTRAPOLATION FORMULA
<b>Read cycle</b>							
Read access time	5	t <sub>ACC</sub>		320	580	ns	292 ns + (0,55 ns/pF) C <sub>L</sub>
	10		130	220	ns	118 ns + (0,23 ns/pF) C <sub>L</sub>	
	15		100	160	ns	92 ns + (0,16 ns/pF) C <sub>L</sub>	
Chip select to output time	5	t <sub>CO</sub>			180	ns	
	10				70	ns	
	15				50	ns	
Address hold time	5	t <sub>OA</sub>	0			ns	
	10		0			ns	
	15		0			ns	
Output hold time with respect to address input	5	t <sub>VAL1</sub>	60	170		ns	142 ns + (0,55 ns/pF) C <sub>L</sub>
	10		20	50		ns	38 ns + (0,23 ns/pF) C <sub>L</sub>
	15		15	40		ns	32 ns + (0,16 ns/pF) C <sub>L</sub>
Output hold time with respect to chip select input	5	t <sub>COH</sub>			130	ns	
	10				70	ns	
	15				60	ns	
Output floating time with respect to chip select input	5	t <sub>COF</sub>	0			ns	
	10		0			ns	
	15		0			ns	
Read cycle time	5	t <sub>RC</sub>	580			ns	
	10		220			ns	
	15		160			ns	
Output transition times LOW to HIGH	5	t <sub>TLH</sub>		60	120	ns	10 ns + (1,0 ns/pF) C <sub>L</sub>
	10			30	60	ns	9 ns + (0,42 ns/pF) C <sub>L</sub>
	15			20	40	ns	6 ns + (0,28 ns/pF) C <sub>L</sub>
HIGH to LOW	5	t <sub>THL</sub>		40	80	ns	14 ns + (0,52 ns/pF) C <sub>L</sub>
	10			22	40	ns	11 ns + (0,22 ns/pF) C <sub>L</sub>
	15			15	30	ns	7 ns + (0,16 ns/pF) C <sub>L</sub>

256-bit, 1-bit per word random access memories

HEF4720B  
HEF4720V

**AC CHARACTERISTICS**

$V_{SS} = 0\text{ V}$ ;  $T_{amb} = 25\text{ }^{\circ}\text{C}$ ;  $C_L = 50\text{ pF}$ ; input transition times  $\leq 20\text{ ns}$

	$V_{DD}$ V	SYMBOL	MIN.	TYP.	MAX.
<b>Write cycle</b>					
Write cycle time	5	$t_{WC}$	580		ns
	10		220		ns
	15		160		ns
Address to write set-up time	5	$t_{AW}$	110		ns
	10		50		ns
	15		50		ns
Write pulse width	5	$t_{WP}$	370		10 000 ns
	10		130		10 000 ns
	15		80		10 000 ns
Write recovery time	5	$t_{WR}$	100		ns
	10		40		ns
	15		30		ns
Data set-up time	5	$t_{DW}$	250		ns
	10		100		ns
	15		80		ns
Data hold time	5	$t_{DH}$	100		ns
	10		30		ns
	15		20		ns
Chip select set-up time with respect to write pulse	5	$t_{CSW}$	370		ns
	10		130		ns
	15		80		ns
Chip select hold time with respect to write pulse	5	$t_{CSH}$	0		ns
	10		0		ns
	15		0		ns
Chip select lead time over write pulse to prevent writing	5	$t_{CSL}$	0		ns
	10		0		ns
	15		0		ns

256-bit, 1-bit per word random access memories

HEF4720B  
HEF4720V

	V <sub>DD</sub> V	SYMBOL	MIN.	TYP.	MAX.
<b>Read-modify-write cycle</b>					
Read enable hold time	5		0		ns
	10	t <sub>RH</sub>	0		ns
	15		0		ns
Output hold time with respect to write pulse	5		60		ns
	10	t <sub>VAL2</sub>	20		ns
	15		15		ns
Read-modify-write cycle time	5		1050		ns
	10	t <sub>RWC</sub>	390		ns
	15		270		ns

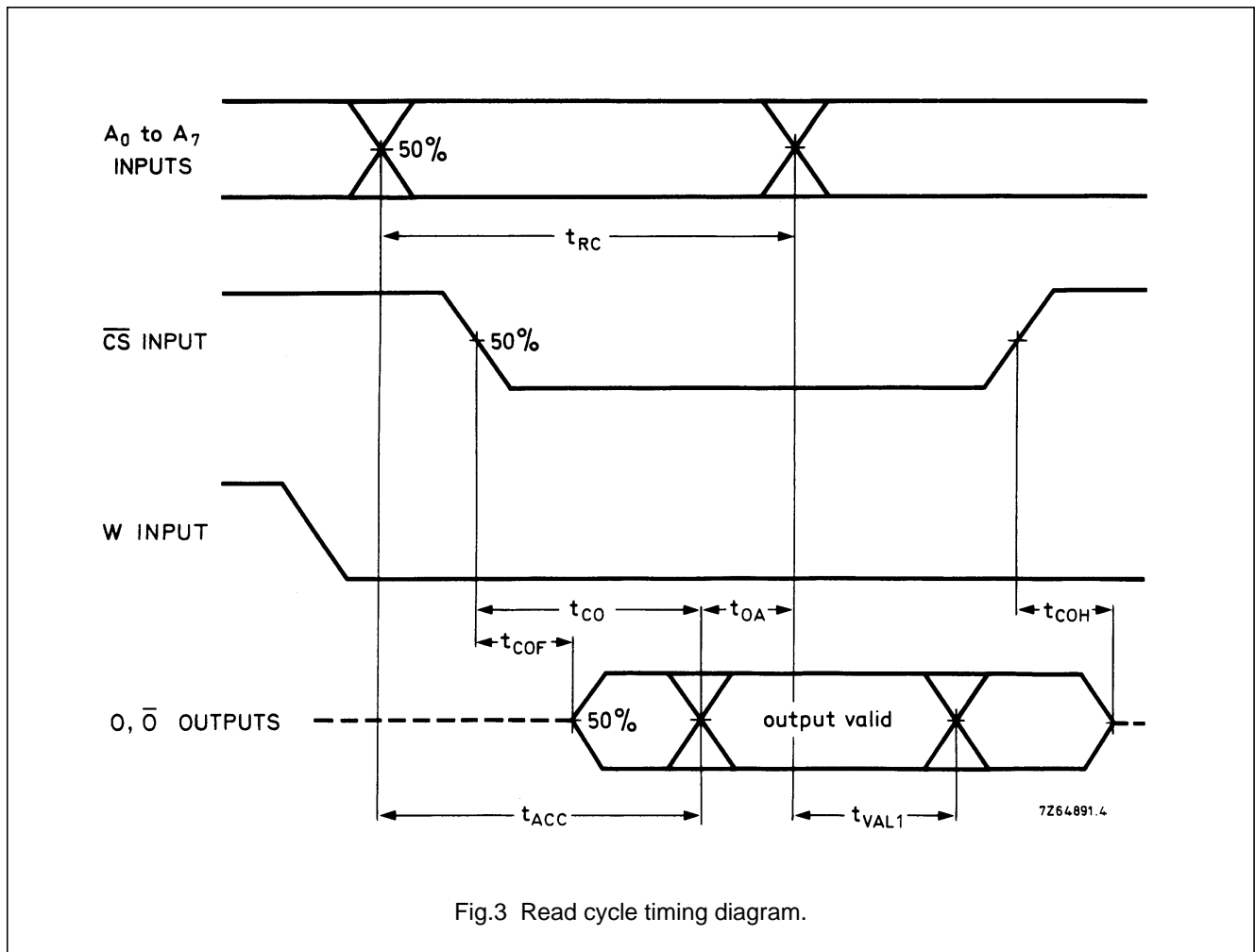

Fig.3 Read cycle timing diagram.

256-bit, 1-bit per word random access memories

HEF4720B  
HEF4720V

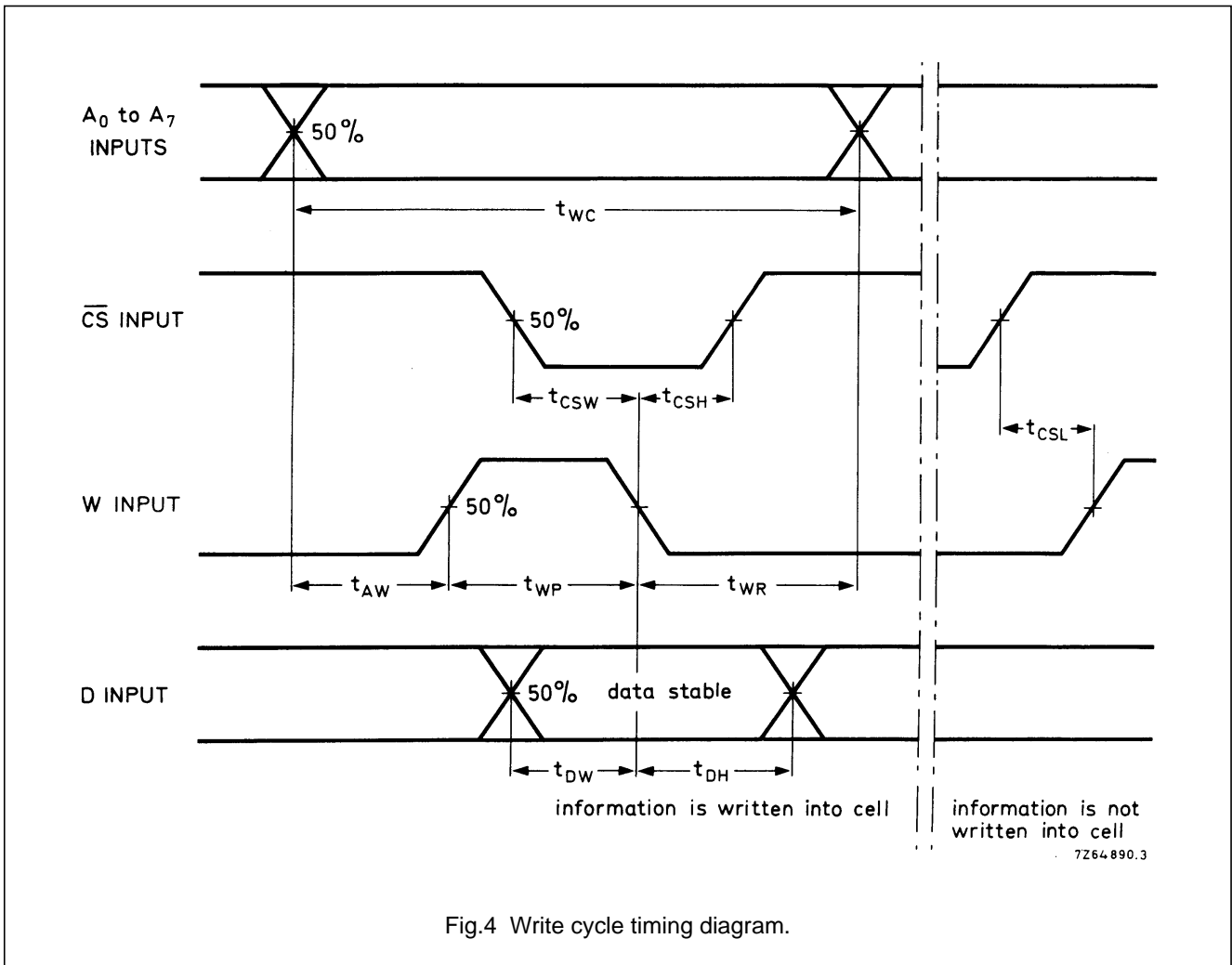
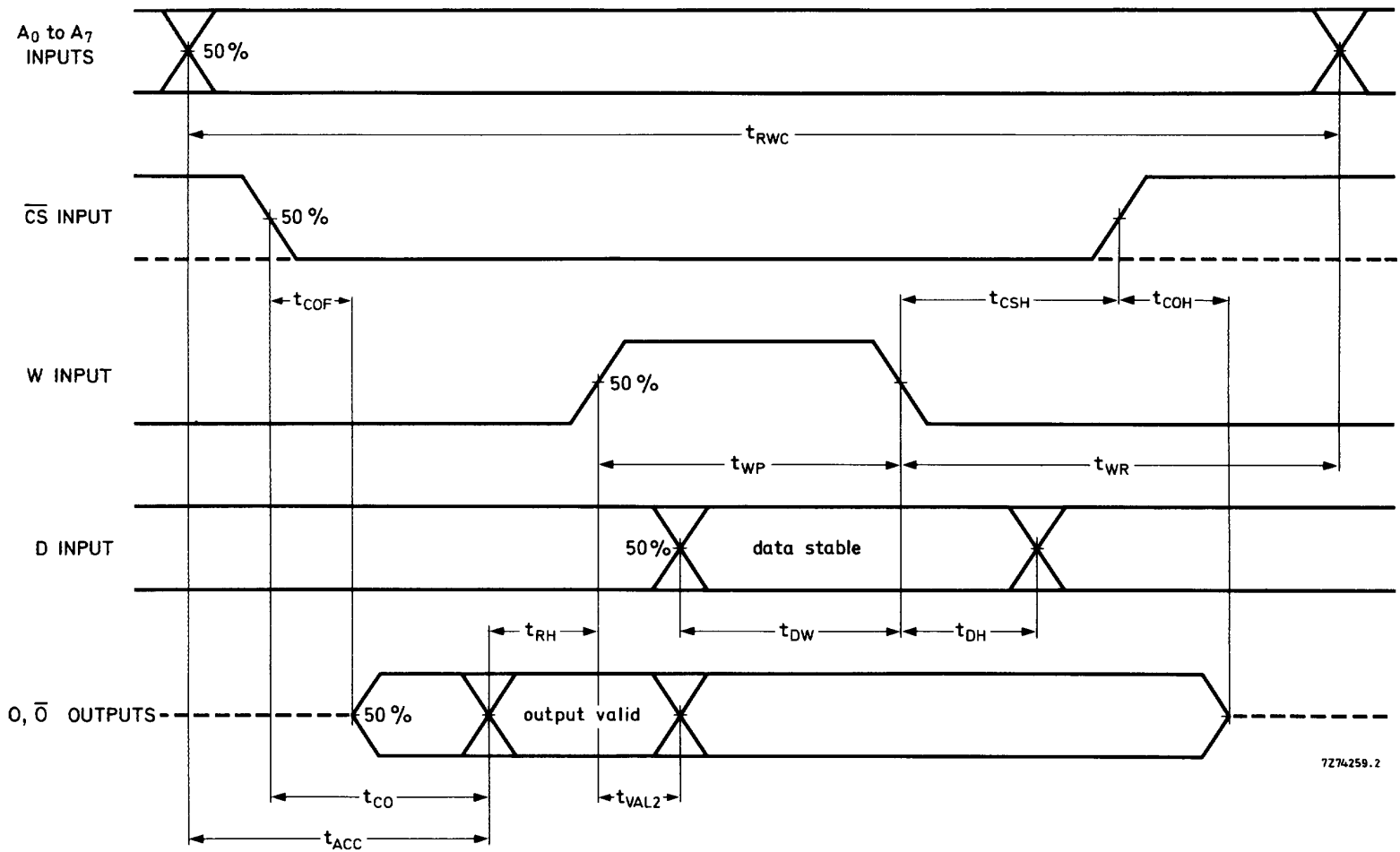

Fig.4 Write cycle timing diagram.

256-bit, 1-bit per word random access memories

HEF4720B  
HEF4720V



7274259.2

Fig.5 Read-modify-write cycle timing diagram.

---

**256-bit, 1-bit per word random access memories**

---

HEF4720B  
HEF4720V

---

**APPLICATION INFORMATION****Extension of memory capacity**

The memory capacity of the HEF4720B; V is 256 bits (or 256 words of 1 bit). The capacity of a system can be extended in various ways by the connection of further HEF4720B; V ICs.

*Extending the word length*

By connecting a number of HEF4720B; V ICs as shown in Fig.6, the word length (i.e. bits per word) is multiplied by that number. That is, each device stores 1 bit per word but the total number of words remains 256. For example, if four devices are used in this way, 256 four-binary-bit words can be stored.

*Extending the number of words*

If a number of HEF4720B; V ICs are connected as shown in Fig.7, the words available are multiplied by that number, but the word length remains 1 bit. Notice that in this case additional addresses are used in conjunction with the  $\overline{CS}$  input. In the case shown in Fig.7 ( $4 \times$  HEF4720B; V in parallel), the addresses and data inputs are loaded with four inputs (= 20 pF), the  $\overline{CS}$  inputs are loaded with one input each.

*Extending both the word length and number of words*

Figure 8 shows how a combination of the extensions described above can be used to obtain both greater word length and additional words. It is clear that the capacitive load of the driving circuits puts a limit to the free choice of the interface. In Fig.8, each address is loaded with 16 inputs, i.e.  $16 \times 5 = 80$  pF: each  $\overline{CS}$  inverter is loaded with 8 inputs, i.e.  $8 \times 5 = 40$  pF. The data inverters in this case are loaded with only two inputs each.

256-bit, 1-bit per word random access memories

HEF4720B  
HEF4720V

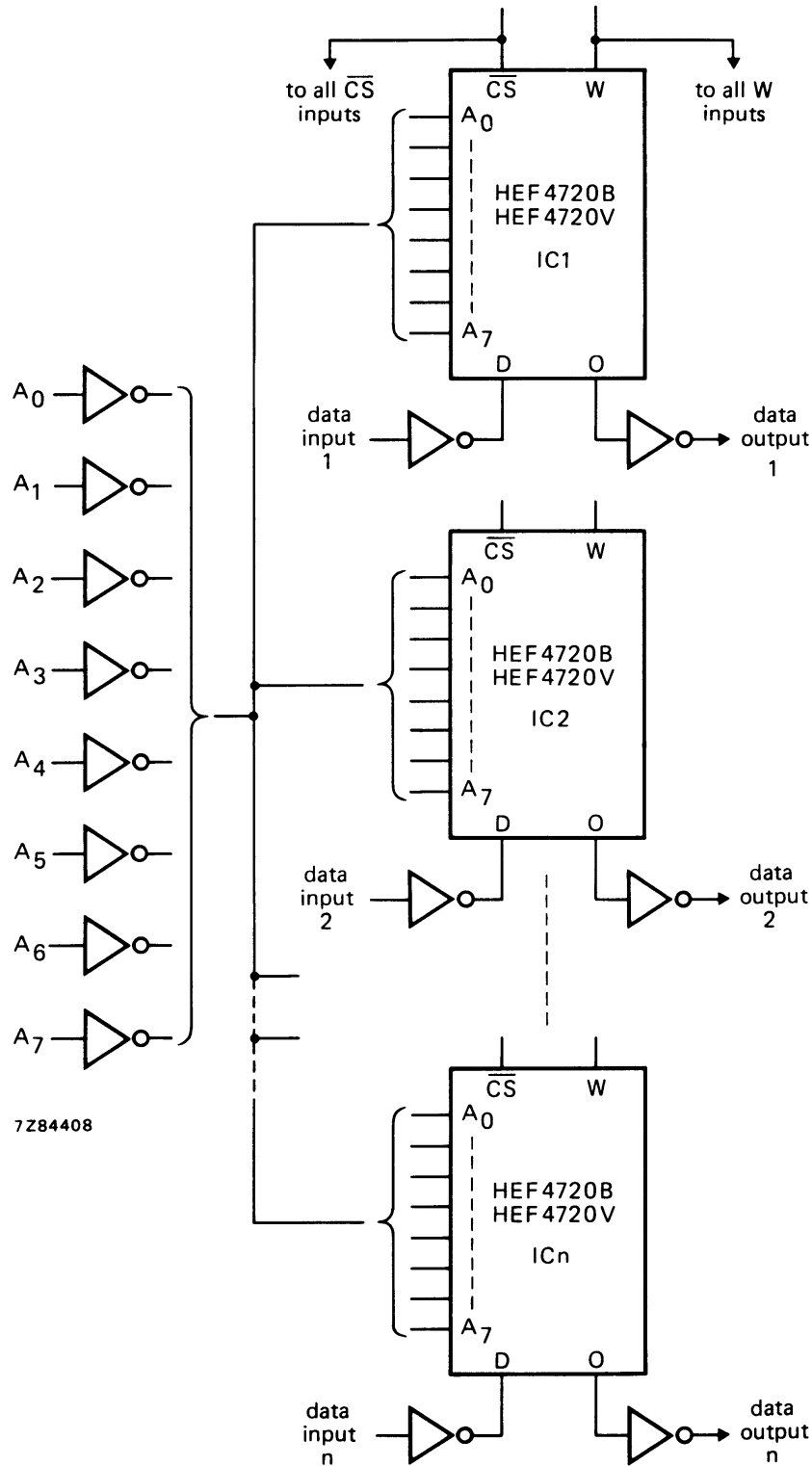

Fig.6 Using extra HEF4720B; V ICs to extend the word length.

# 256-bit, 1-bit per word random access memories

HEF4720B  
HEF4720V

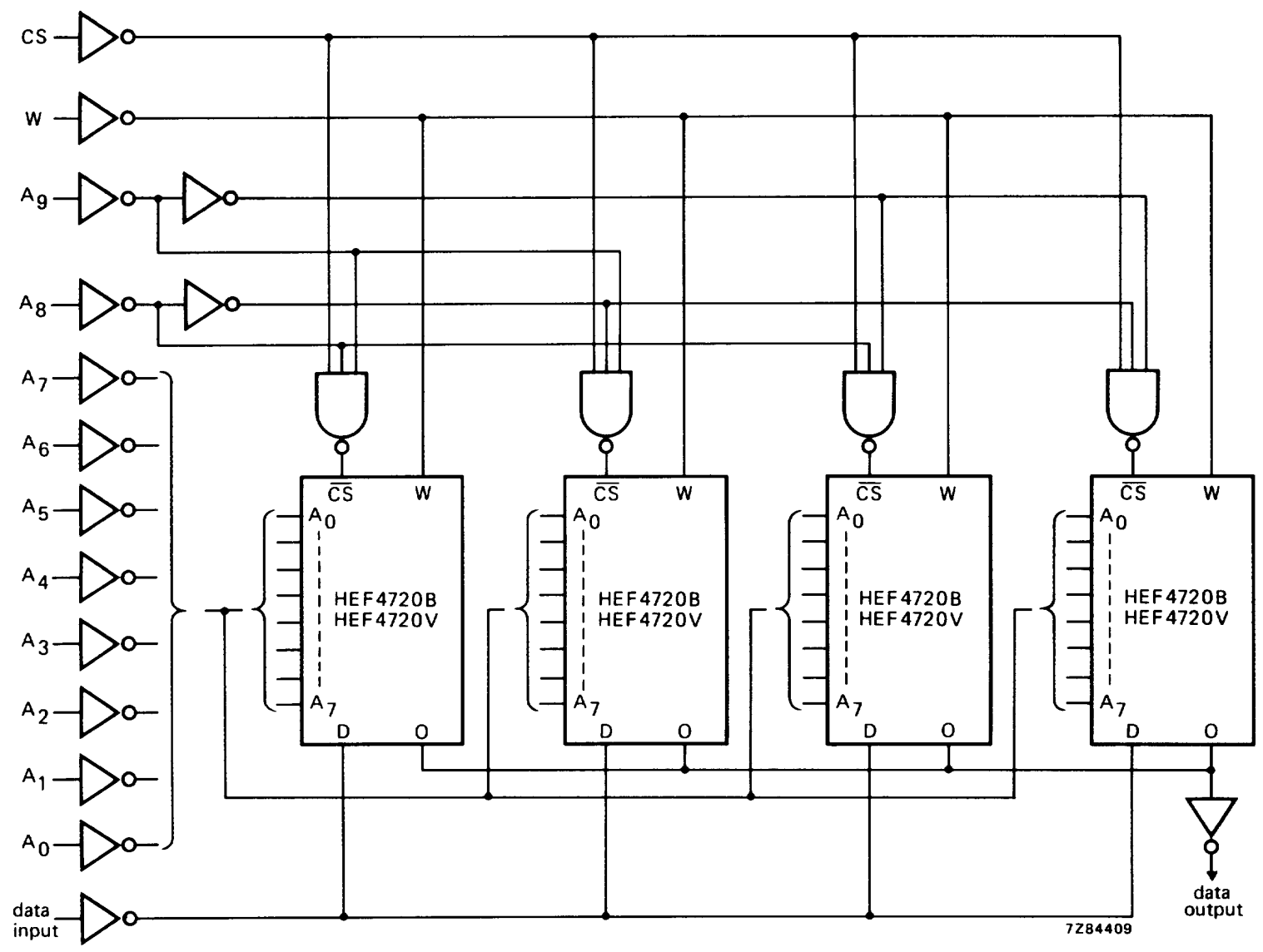

Fig.7 Using extra HEF4720B; V ICs to obtain more words.

256-bit, 1-bit per word random access memories

HEF4720B  
HEF4720V

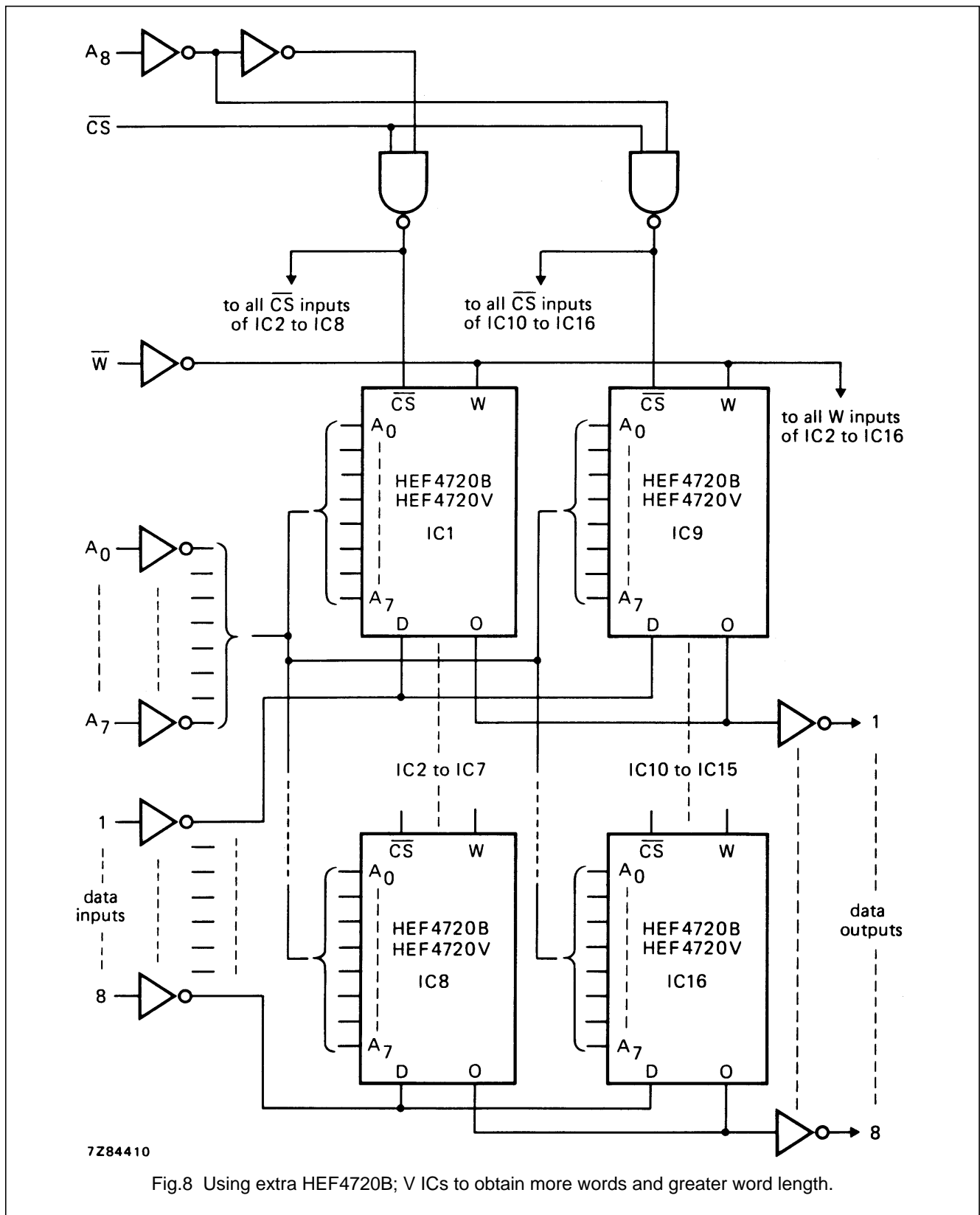

Fig.8 Using extra HEF4720B; V ICs to obtain more words and greater word length.

---

## 256-bit, 1-bit per word random access memories

---

HEF4720B  
HEF4720V

---

### Memory retention

It is sometimes necessary to ensure that the information stored in the memory cannot be erased inadvertently. This can be arranged by adding detection circuits, by measures in the timing, and by the addition of a battery. With the HEF4720B; V, memory retention is very easily obtained because its current drain in the stand-by condition is almost zero. The wide supply voltage range makes it possible to keep the memory active by means of a simple battery, thereby preventing information loss.

In designing the memory retention circuits, two aspects should be kept in mind. The memory retention will not function in an optimum way if the battery voltage is low or if the voltage transitions at the address input are too slow. The first of these is usually the result of using too simple a battery back-up circuit, e.g. a battery charged via a diode from the TTL supply voltage. In this case, the LOCMOS supply voltage falls below the safe operating voltage. Special arrangements should be made to overcome this.

Slow address transitions (the second cause of memory loss) are due to a long RC-time in the power system. When the power is switched on or off, the 5 V line changes between 0 and 5 V in milliseconds to seconds so producing a correspondingly long transition time in the various logic outputs. This creates problems in the proper operation of the HEF4720B; V, with loss of memory as a possible result. This can be prevented by ensuring that input rise and fall times do not exceed 10  $\mu$ s.

Three possibilities for controlling the rise and fall times at the HEF4720B; V interface are given here:

1. LOCMOS gates can be connected between the address latch and the HEF4720B; V (Fig.9). In the event of a low voltage, or mains supply failure, the gates can be blocked by a signal from the memory retention logic thus isolating the HEF4720B; V from the address and CS inputs.
2. The interface power supply can be separated from the TTL power supply by means of a low-value resistor (Fig.10); a thyristor is connected from the interface power supply to earth. The system is arranged so that, upon switching off or failure of the interface supply, the thyristor turns on thus ensuring a rapid fall of the supply voltage.
3. The best solution is to select the interface circuits from the LOCMOS family and to feed all these circuits from the battery (Fig.11). These stages then remain active when the TTL 5 V supply fails. The interface circuits are mostly only active on a clock pulse, have the possibility of being inactive on a gate level, or can be forced into one position.

256-bit, 1-bit per word random access memories

HEF4720B  
HEF4720V

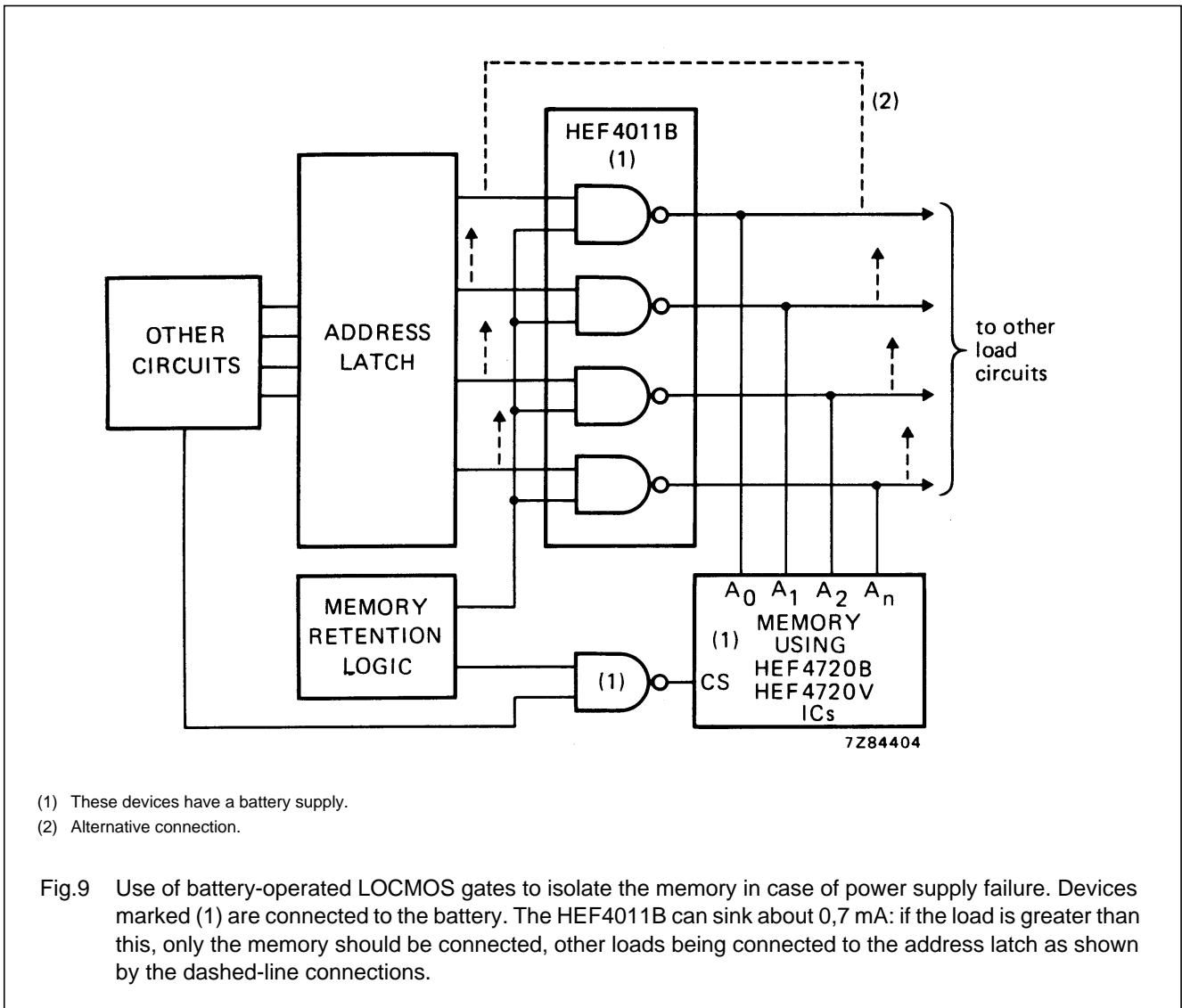

256-bit, 1-bit per word random access memories

HEF4720B  
HEF4720V

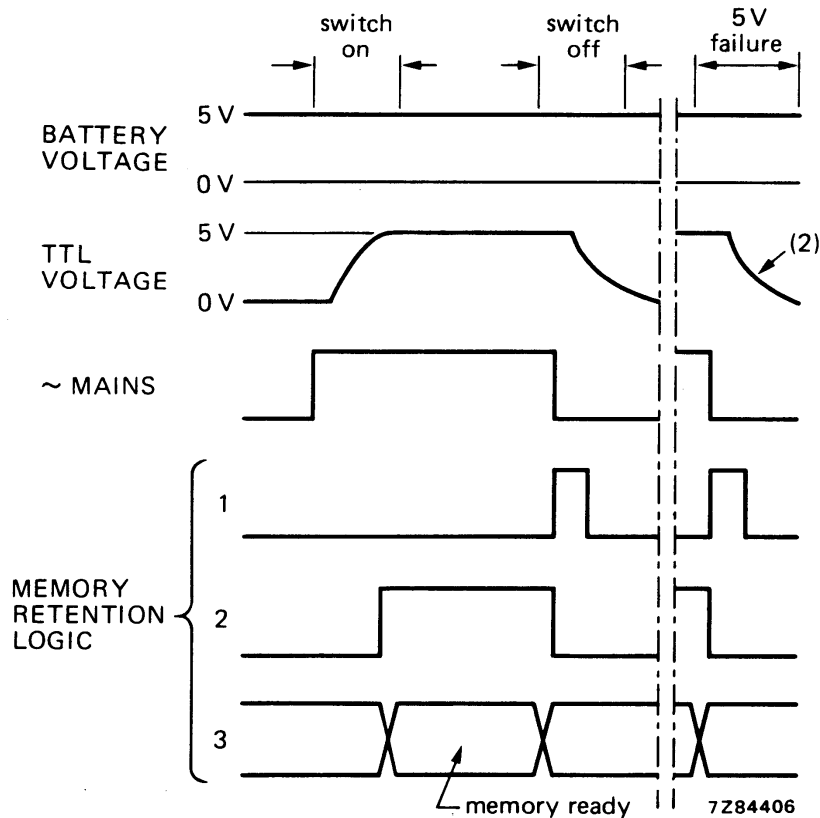
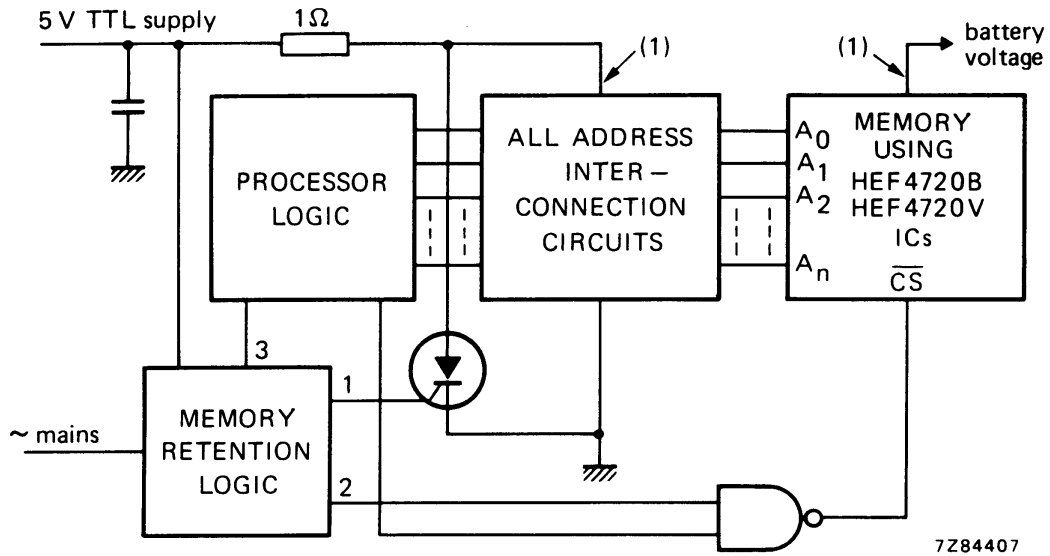

- (1) Leads should be so arranged to prevent cross-talk; thyristor connections must be short.
- (2) Slope > 500 mV/μs in the vicinity of the threshold.

Fig.10 Using a thyristor to ensure a rapid fall of interface supply at switch-off or supply failure.

256-bit, 1-bit per word random access memories

HEF4720B  
HEF4720V

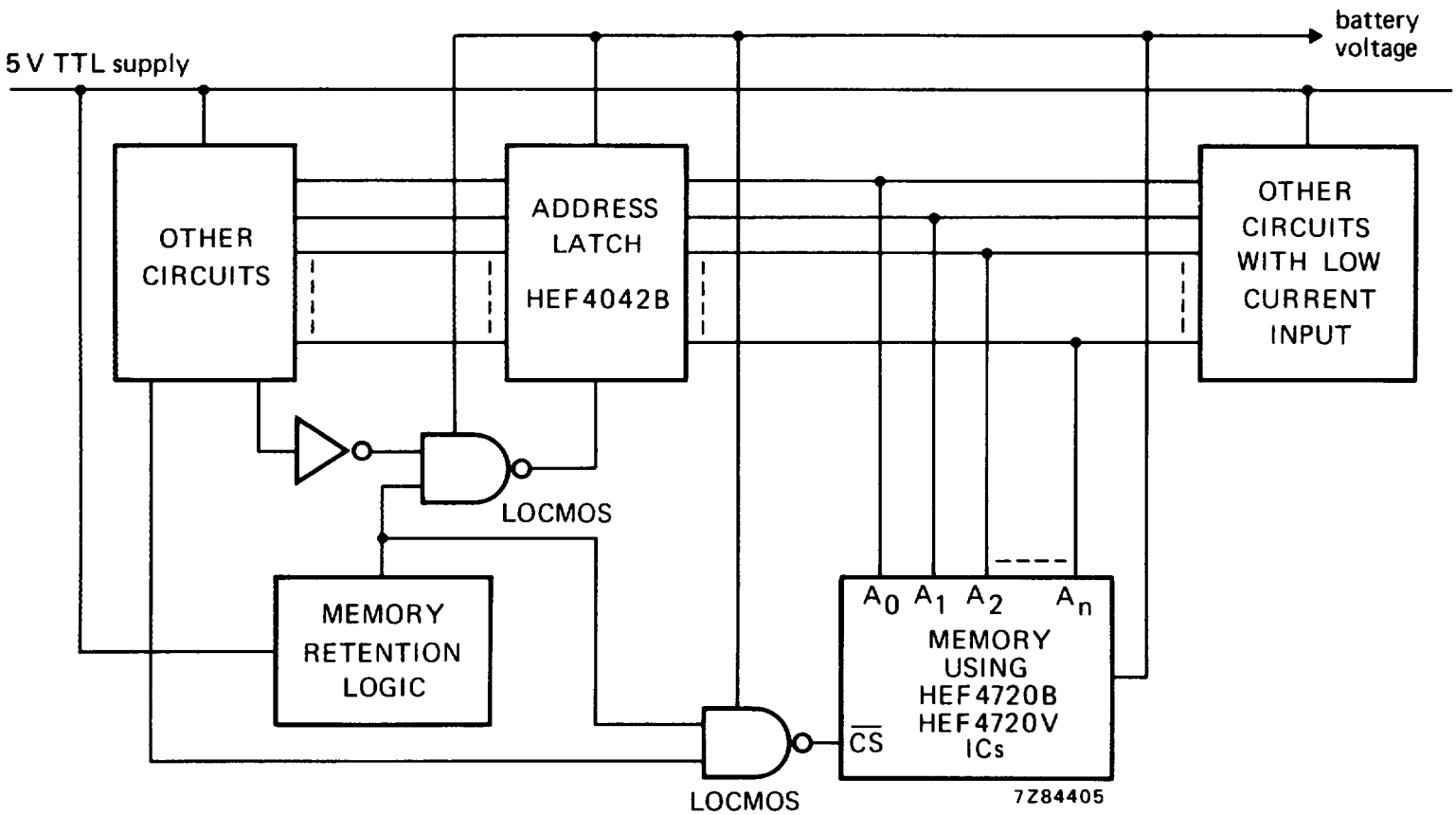

Fig.11 Preferred solution for memory retention; all interface circuits are battery-fed LOC MOS. Note that maximum sink current of the HEF4042B is about 1,5 mA.



LittleDiode supplies new, hard to find or obsolete electronic components and semiconductors all over the world.

With over two million different components listed you are sure to find the part you need.

Feel free to visit us today at our online store:

[LittleDiode.com](http://LittleDiode.com)

Looking forward to providing you with the best possible service.