

**Rectifier (PWM) Controller and Output Voltage Monitor**

The HIP6002 provides complete control and protection for a DC-DC converter optimized for high-performance microprocessor applications. It is designed to drive two N-Channel MOSFETs in a synchronous-rectified buck topology. The HIP6002 integrates all of the control, output adjustment, monitoring and protection functions into a single package.

The output voltage of the converter is easily adjusted and precisely regulated. The HIP6002 includes a 4-Input Digital-to-Analog Converter (DAC) that adjusts the output voltage from 2.0VDC to 3.5VDC in 0.1V increments. The precision reference and voltage-mode regulator hold the selected output voltage to within  $\pm 1\%$  over temperature and line voltage variations.

The HIP6002 provides simple, single feedback loop, voltage-mode control with fast transient response. It includes a 200kHz free-running triangle-wave oscillator that is adjustable from below 50kHz to over 1MHz. The error amplifier features a 15MHz gain-bandwidth product and 6V/ $\mu$ s slew rate which enables high converter bandwidth for fast transient performance. The resulting PWM duty ratio ranges from 0% to 100%.

The HIP6002 monitors the output voltage with a window comparator that tracks the DAC output and issues a Power Good signal when the output is within  $\pm 10\%$ . The HIP6002 protects against over-current conditions by inhibiting PWM operation. Built-in over-voltage protection triggers an external SCR to crowbar the input supply. The HIP6002 monitors the current by using the  $r_{DS(ON)}$  of the upper MOSFET which eliminates the need for a current sensing resistor.

**Pinout**

**HIP6002 (SOIC)  
TOP VIEW**

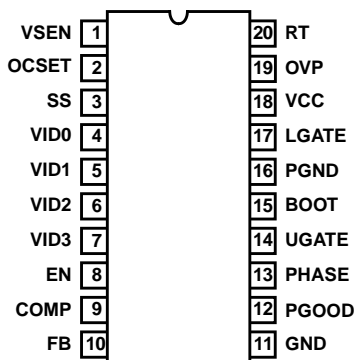

**Features**

- Drives Two N-Channel MOSFETs
- Operates From +5V or +12V Input
- Simple Single-Loop Control Design
  - Voltage-Mode PWM Control
- Fast Transient Response
  - High-Bandwidth Error Amplifier
  - Full 0% to 100% Duty Ratio
- Excellent Output Voltage Regulation
  - $\pm 1\%$  Over Line Voltage and Temperature
- 4-Bit Digital-to-Analog Output Voltage Selection
  - Wide Range . . . . . 2.0VDC to 3.5VDC
  - 0.1V Binary Steps
- Power-Good Output Voltage Monitor
- Over-Voltage and Over-Current Fault Monitors
  - Does Not Require Extra Current Sensing Element
  - Uses MOSFET's  $r_{DS(ON)}$
- Small Converter Size
  - Constant Frequency Operation
  - 200kHz Free-Running Oscillator Programmable from 50kHz to Over 1MHz

**Applications**

- Power Supply for Pentium®, Pentium Pro, PowerPC™ and Alpha™ Microprocessors
- High-Power 5V to 3.xV DC-DC Regulators
- Low-Voltage Distributed Power Supplies

**Ordering Information**

PART NUMBER	TEMP. RANGE (°C)	PACKAGE	PKG. NO.
HIP6002CB	0 to 70	20 Ld SOIC	M20.3

Alpha Micro™ is a trademark of Digital Computer Equipment Corporation.  
 Pentium® is a registered trademark of Intel Corporation.  
 PowerPC™ is a registered trademark of IBM.

Typical Application

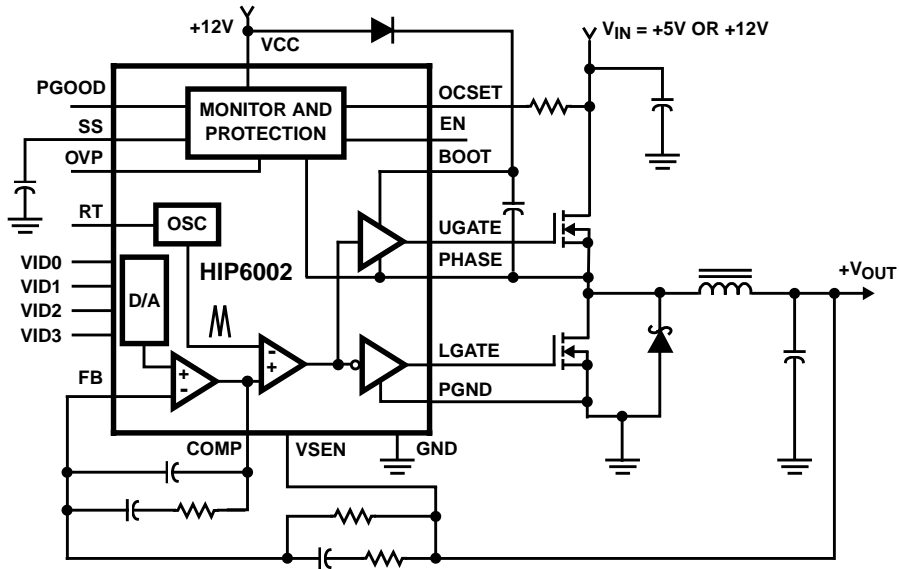

Block Diagram

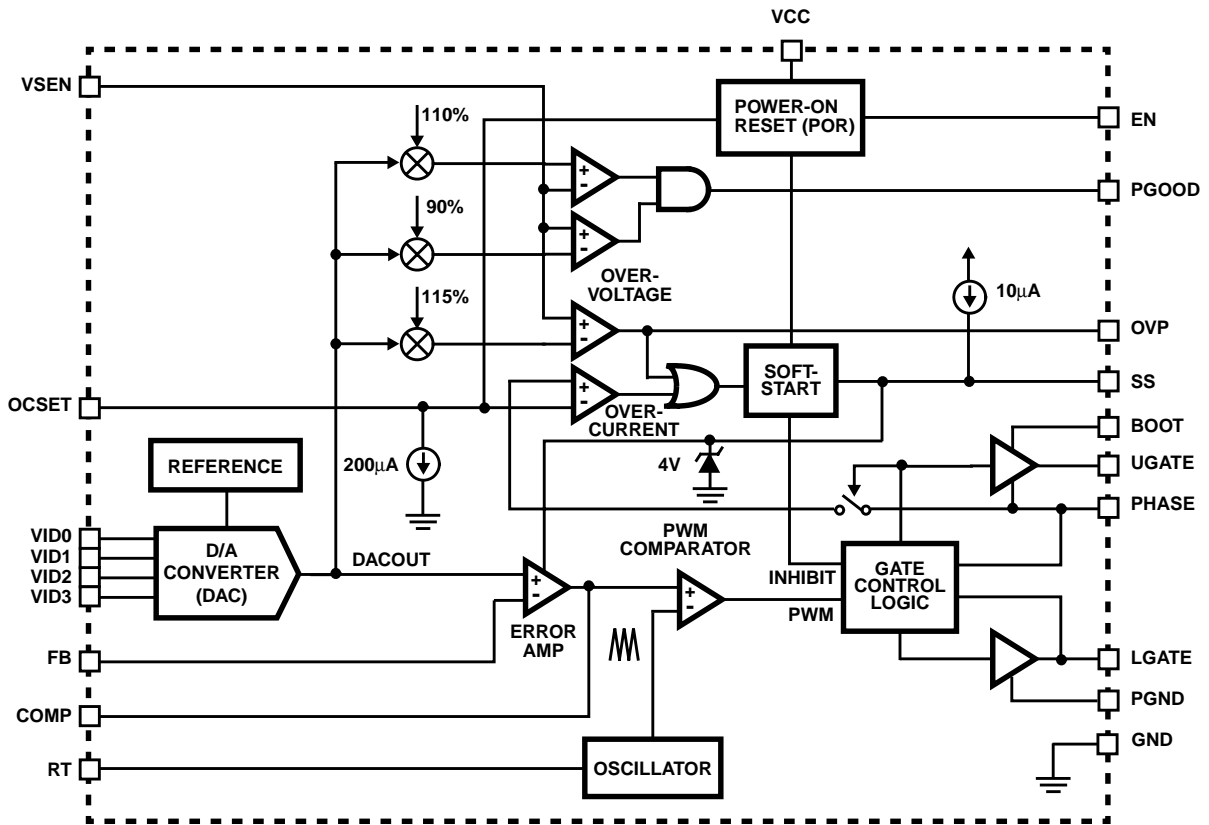

# HIP6002

## Absolute Maximum Ratings

Supply Voltage  $V_{CC}$  ..... +15V  
 Boot Voltage,  $V_{BOOT} - V_{PHASE}$  ..... +15V  
 Input, Output or I/O Voltage ..... GND -0.3V to  $V_{CC} + 0.3V$   
 ESD Classification ..... Class 2

## Operating Conditions

Supply Voltage,  $V_{CC}$  ..... +12V to  $\pm 10\%$   
 Ambient Temperature Range .....  $0^{\circ}$  to  $70^{\circ}C$   
 Junction Temperature Range .....  $0^{\circ}C$  to  $125^{\circ}C$

## Thermal Information

Thermal Resistance (Typical, Note 1)  $\theta_{JA}$  ( $^{\circ}C/W$ )  
 SOIC Package ..... 115  
 Maximum Junction Temperature (Plastic Package) .....  $150^{\circ}C$   
 Maximum Storage Temperature Range .....  $-65^{\circ}C$  to  $150^{\circ}C$   
 Maximum Lead Temperature (Soldering 10s) .....  $300^{\circ}C$   
 (SOIC - Lead Tips Only)

*CAUTION: Stresses above those listed in "Absolute Maximum Ratings" may cause permanent damage to the device. This is a stress only rating and operation of the device at these or any other conditions above those indicated in the operational sections of this specification is not implied.*

### NOTE:

- $\theta_{JA}$  is measured with the component mounted on a low effective thermal conductivity test board in free air. See Tech Brief 379 for details.

## Electrical Specifications Recommended Operating Conditions, unless otherwise noted

PARAMETER	SYMBOL	TEST CONDITIONS	MIN	TYP	MAX	UNITS
<b>VCC SUPPLY CURRENT</b>						
Nominal Supply	$I_{CC}$	EN = $V_{CC}$ ; UGATE and LGATE Open	-	5	-	mA
Shutdown Supply		EN = 0V	-	50	100	$\mu A$
<b>POWER-ON RESET</b>						
Rising $V_{CC}$ Threshold		$V_{OCSET} = 4.5V$	-	-	10.4	V
Falling $V_{CC}$ Threshold		$V_{OCSET} = 4.5V$	8.2	-	-	V
Enable - Input threshold Voltage		$V_{OCSET} = 4.5V$	0.8	-	2.0	V
Rising $V_{OCSET}$ Threshold			-	1.26	-	V
<b>OSCILLATOR</b>						
Free Running Frequency		$R_T = OPEN$	185	200	215	kHz
Programmable Variation		$6k\Omega < R_T$ to GND $< 200k\Omega$	-15	-	+15	%
Ramp Amplitude	$\Delta V_{OSC}$	$R_T = OPEN$	-	1.9	-	$V_{P-P}$
<b>REFERENCE AND DAC</b>						
DACOUT Voltage Accuracy			-1.0	-	+1.0	%
<b>ERROR AMPLIFIER</b>						
DC Gain	$G_0$		-	88	-	dB
Gain-Bandwidth Product	GBW		-	15	-	MHz
Slew Rate	SR	COMP = 10pF	-	6	-	$V/\mu s$
<b>GATE DRIVERS</b>						
Upper Gate Source	$I_{UGATE}$	$V_{BOOT} - V_{PHASE} = 12V$ , $V_{UGATE} = 6V$	350	500	-	mA
Upper Gate Sink	$R_{UGATE}$	$I_{LGATE} = 0.3A$	-	5.5	10	$\Omega$
Lower Gate Source	$I_{LGATE}$	$V_{CC} = 12V$ , $V_{LGATE} = 6V$	300	450	-	mA
Lower Gate Sink	$R_{LGATE}$	$I_{LGATE} = 0.3A$	-	3.5	6.5	$\Omega$
<b>PROTECTION</b>						
Over-Voltage Trip		% Over Nominal DACOUT Voltage	-	115	120	%
OCSET Current Source	$I_{OCSET}$	$V_{OCSET} = 4.5V_{DC}$	170	200	230	$\mu A$
OVP Sourcing Current	$I_{OVP}$	$V_{SEN} = 5.5V$ , $V_{OVP} = 0V$	60	-	-	mA
Soft Start Current	$I_{SS}$		-	10	-	$\mu A$
<b>POWER GOOD</b>						
Upper Threshold ( $V_{SEN}/DACOUT$ )		$V_{SEN}$ Rising	106	-	111	%
Lower Threshold ( $V_{SEN}/DACOUT$ )		$V_{SEN}$ Falling	89	-	94	%
Hysteresis ( $V_{SEN}/DACOUT$ )		Upper and Lower Threshold	-	2	-	%
PGOOD Voltage Low	$V_{PGOOD}$	$I_{PGOOD} = -5mA$	-	0.5	-	V

## Typical Performance Curves

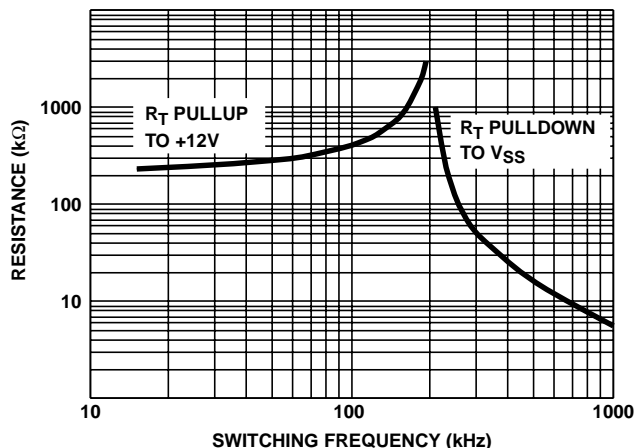

FIGURE 1.  $R_T$  RESISTANCE vs FREQUENCY

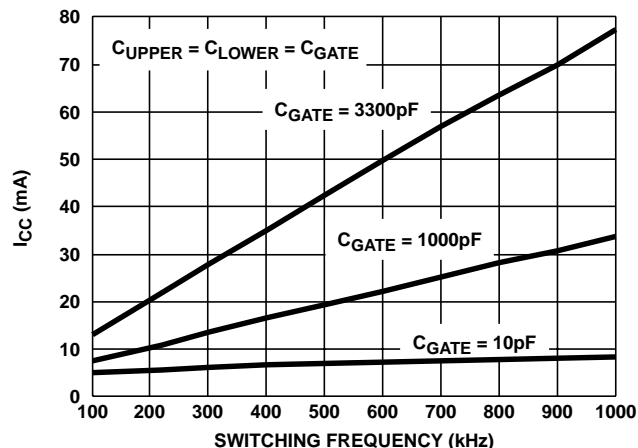
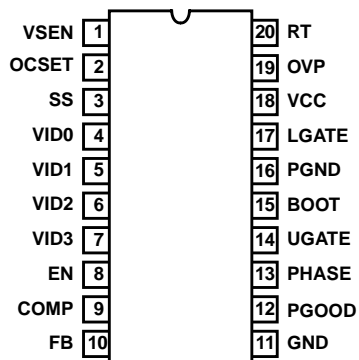

FIGURE 2. BIAS SUPPLY CURRENT vs FREQUENCY

## Functional Pin Description



### VSEN (Pin 1)

This pin is connected to the converters output voltage. The PGOOD and OVP comparator circuits use this signal to report output voltage status and for overvoltage protection.

### OCSET (Pin 2)

Connect a resistor ( $R_{OCSET}$ ) from this pin to the drain of the upper MOSFET.  $R_{OCSET}$ , an internal  $200\mu A$  current source ( $I_{OCS}$ ), and the upper MOSFET on-resistance ( $r_{DS(ON)}$ ) set the converter over-current (OC) trip point according to the following equation:

$$I_{PEAK} = \frac{I_{OCS} \cdot R_{OCSET}}{r_{DS(ON)}}$$

An over-current trip cycles the soft-start function.

### SS (Pin 3)

Connect a capacitor from this pin to ground. This capacitor, along with an internal  $10\mu A$  current source, sets the soft-start interval of the converter.

### VID0-3 (Pins 4-7)

VID0-3 are the input pins to the 4-bit DAC. The states of these four pins program the internal voltage reference (DACOUT). The level of DACOUT sets the converter output voltage. It also sets the PGOOD and OVP thresholds. Table 1 specifies DACOUT for the 16 combinations of DAC inputs.

### EN (Pin 8)

This pin is the open-collector enable pin. Pull this pin below 1V to disable the converter. In shutdown, the soft start pin is discharged and the UGATE pin is held low.

### COMP (Pin 9) and FB (Pin 10)

COMP and FB are the available external pins of the error amplifier. The FB pin is the inverting input of the error amplifier and the COMP pin is the error amplifier output. These pins are used to compensate the voltage-control feedback loop of the converter.

### GND (Pin 11)

Signal ground for the IC. All voltage levels are measured with respect to this pin.

### PGOOD (Pin 12)

PGOOD is an open collector output used to indicate the status of the converter output voltage. This pin is pulled low when the converter output is not within  $\pm 10\%$  of the DACOUT reference voltage.

### PHASE (Pin 13)

Connect the PHASE pin to the upper MOSFET source. This input pin is used to monitor the voltage drop across the MOSFET for over-current protection. This pin also provide the return path for the upper gate drive.

### UGATE (Pin 14)

Connect UGATE to the upper MOSFET gate. This pin provides the gate drive for the upper MOSFET.

**BOOT (Pin 15)**

This pin provides bias voltage to the upper MOSFET driver. A bootstrap circuit may be used to create a BOOT voltage suitable to drive a standard N-Channel MOSFET.

**PGND (Pin 16)**

This is the power ground connection. Tie the lower MOSFET source to this pin.

**LGATE (Pin 17)**

Connect LGATE to the lower MOSFET gate. This pin provides the gate drive for the lower MOSFET.

**VCC (Pin 18)**

Provide a 12V bias supply for the chip to this pin.

**OVP (Pin 19)**

The OVP pin can be used to drive an external SCR in the event of an overvoltage condition.

**RT (Pin 20)**

This pin provides oscillator switching frequency adjustment. By placing a resistor ( $R_T$ ) from this pin to GND, the nominal 200kHz switching frequency is increased according to the following equation:

$$F_s \approx 200\text{kHz} + \frac{5 \cdot 10^6}{R_T(\text{k}\Omega)} \quad (R_T \text{ to GND})$$

Conversely, connecting a pull-up resistor ( $R_T$ ) from this pin to  $V_{CC}$  reduces the switching frequency according to the following equation:

$$F_s \approx 200\text{kHz} - \frac{4 \cdot 10^7}{R_T(\text{k}\Omega)} \quad (R_T \text{ to } 12\text{V})$$

**Functional Description**

**Initialization**

The HIP6002 automatically initializes upon receipt of power. Special sequencing of the input supplies is not necessary. The Power-On Reset (POR) function continually monitors the input supply voltages and the enable (EN) pin. The POR monitors the bias voltage at the VCC pin and the input voltage ( $V_{IN}$ ) on the OCSET pin. The level on OCSET is equal to  $V_{IN}$  less a fixed voltage drop (see over-current protection). With the EN pin held to  $V_{CC}$ , the POR function initiates soft start operation after both input supply voltages exceed their POR thresholds. For operation with a single +12V power source,  $V_{IN}$  and  $V_{CC}$  are equivalent and the +12V power source must exceed the rising  $V_{CC}$  threshold before POR initiates operation.

The Power-On Reset (POR) function inhibits operation with the chip disabled (EN pin low). With both input supplies above their POR thresholds, transitioning the EN pin high initiates a soft start interval.

**Soft Start**

The POR function initiates the soft start sequence. An internal 10 $\mu$ A current source charges an external capacitor ( $C_{SS}$ ) on the SS pin to 4V. Soft start clamps the error amplifier output (COMP pin) and reference input (+ terminal of error amp) to the SS pin voltage. Figure 3 shows the soft start interval with  $C_{SS} = 0.1\mu\text{F}$ . Initially the clamp on the error amplifier (COMP pin) controls the converter's output voltage. At  $t_1$  in Figure 3, the SS voltage reaches the valley of the oscillator's triangle wave. The oscillator's triangular waveform is compared to the ramping error amplifier voltage. This generates PHASE pulses of increasing width that charge the output capacitor(s). This interval of increasing pulse width continues to  $t_2$ . With sufficient output voltage, the clamp on the reference input controls the output voltage. This is the interval between  $t_2$  and  $t_3$  in Figure 3. At  $t_3$  the SS voltage exceeds the DACOUT voltage and the output voltage is in regulation. This method provides a rapid and controlled output voltage rise. The PGOOD signal toggles 'high' when the output voltage ( $V_{SEN}$  pin) is within  $\pm 5\%$  of DACOUT. The 2% hysteresis built into the power good comparators prevents PGOOD oscillation due to nominal output voltage ripple.

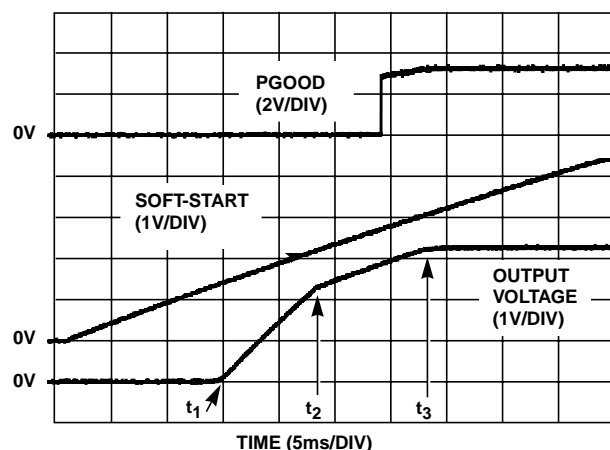

FIGURE 3. SOFT START INTERVAL

**Over-Current Protection**

The over-current function protects the converter from a shorted output by using the upper MOSFET's on-resistance,  $r_{DS(ON)}$  to monitor the current. This method enhances the converter's efficiency and reduces cost by eliminating a current sensing resistor.

The over-current function cycles the soft-start function in a hiccup mode to provide fault protection. A resistor ( $R_{OCSET}$ ) programs the over-current trip level. An internal 200 $\mu$ A current sink develops a voltage across  $R_{OCSET}$  that is referenced to  $V_{IN}$ . When the voltage across the upper MOSFET (also referenced to  $V_{IN}$ ) exceeds the voltage across  $R_{OCSET}$ , the over-current function initiates a soft-start sequence. The soft-start function discharges  $C_{SS}$  with a 10 $\mu$ A current sink and

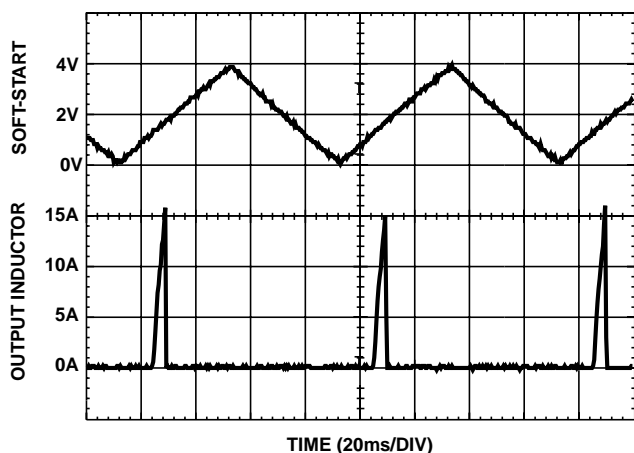

FIGURE 4. OVER-CURRENT OPERATION

inhibits PWM operation. The soft-start function recharges  $C_{SS}$ , and PWM operation resumes with the error amplifier clamped to the SS voltage. Should an overload occur while recharging  $C_{SS}$ , the soft start function inhibits PWM operation while fully charging  $C_{SS}$  to 4V to complete its cycle. Figure 4 shows this operation with an overload condition. Note that the inductor current increases to over 15A during the  $C_{SS}$  charging interval and causes an over-current trip. The converter dissipates very little power with this method. The measured input power for the conditions of Figure 4 is 2.5W.

The over-current function will trip at a peak inductor current ( $I_{PEAK}$ ) determined by:

$$I_{PEAK} = \frac{I_{OCSET} \cdot R_{OCSET}}{r_{DS(ON)}}$$

where  $I_{OCSET}$  is the internal OCSET current source (200 $\mu$ A - typical). The OC trip point varies mainly due to the MOSFET's  $r_{DS(ON)}$  variations. To avoid over-current tripping in the normal operating load range, find the  $R_{OCSET}$  resistor from the equation above with:

1. The maximum  $r_{DS(ON)}$  at the highest junction temperature.
2. The minimum  $I_{OCSET}$  from the Specification Table.
3. Determine  $I_{PEAK}$  for  $I_{PEAK} > I_{OUT(MAX)} + (\Delta I)/2$ , where  $\Delta I$  is the output inductor ripple current.

For an equation for the ripple current see the section under component guidelines titled 'Output Inductor Selection'.

A small ceramic capacitor should be placed in parallel with  $R_{OCSET}$  to smooth the voltage across  $R_{OCSET}$  in the presence of switching noise on the input voltage.

### Output Voltage Program

The output voltage of a HIP6002 converter is digitally programmed to levels between 2VDC and 3.5VDC. The voltage identification (VID) pins program an internal voltage reference (DACOUT) with a 4-bit digital-to-analog converter

(DAC). The level of DACOUT also sets the PGOOD and OVP thresholds. Table 1 specifies the DACOUT voltage for the 16 combinations of open or short connections on the VID pins. The output voltage should not be adjusted while the converter is delivering power. Remove input power or inhibit the converter (EN pin to GND) before changing the output voltage. Adjusting the output voltage during operation could toggle the PGOOD signal and exercise the overvoltage protection.

The DAC function is a precision non-inverting summation amplifier shown in Figure 5. The resistor values shown are only approximations of the actual precision values used. Grounding any combination of the VID pins increases the DACOUT voltage. The 'open' circuit voltage on the VID pins is the band gap reference voltage, 1.26V.

TABLE 1. OUTPUT VOLTAGE PROGRAM

PIN NAME				NOMINAL DACOUT VOLTAGE
VID3	VID2	VID1	VID0	
1	1	1	1	2.0
1	1	1	0	2.1
1	1	0	1	2.2
1	1	0	0	2.3
1	0	1	1	2.4
1	0	1	0	2.5
1	0	0	1	2.6
1	0	0	0	2.7
0	1	1	1	2.8
0	1	1	0	2.9
0	1	0	1	3.0
0	1	0	0	3.1
0	0	1	1	3.2
0	0	1	0	3.3
0	0	0	1	3.4
0	0	0	0	3.5

NOTE: 0 = connected to GND or  $V_{SS}$ , 1 = OPEN.

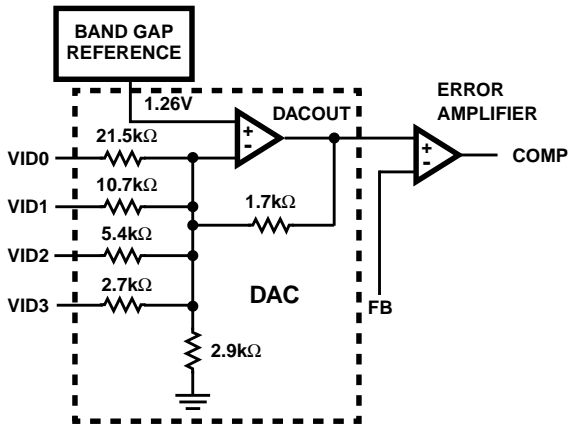

FIGURE 5. DAC FUNCTION SCHEMATIC

**Application Guidelines**

**Layout Considerations**

As in any high frequency switching converter, layout is very important. Switching current from one power device to another can generate voltage transients across the impedances of the interconnecting bond wires and circuit traces. These interconnecting impedances should be minimized by using wide, short printed circuit traces. The critical components should be located as close together as possible, using ground plane construction or single point grounding.

Figure 6 shows the critical power components of the converter. To minimize the voltage overshoot, the interconnecting wires indicated by heavy lines should be part of ground or power plane in a printed circuit board. The components shown in Figure 6 should be located as close together as possible. Please note that the capacitors  $C_{IN}$  and  $C_O$  each represent numerous physical capacitors. Locate the HIP6002 within 3 inches of the MOSFETs, Q1 and Q2. The circuit traces for the MOSFETs' gate and source connections from the HIP6002 must be sized to handle up to 1A peak current.

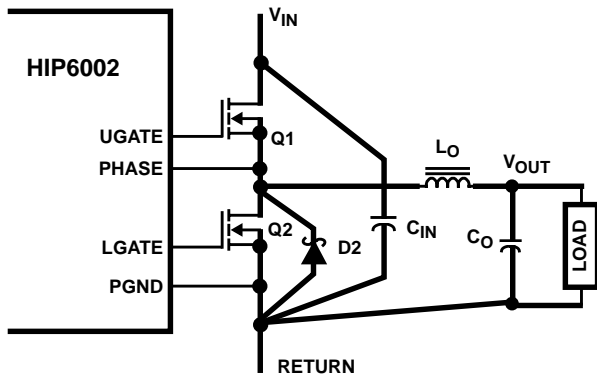

FIGURE 6. PRINTED CIRCUIT BOARD POWER AND GROUND PLANES OR ISLANDS

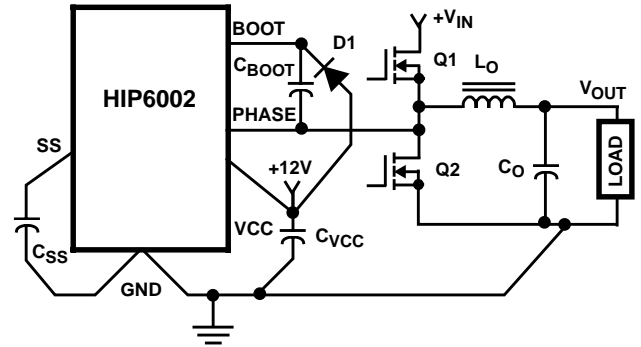

FIGURE 7. PRINTED CIRCUIT BOARD SMALL SIGNAL LAYOUT GUIDELINES

Figure 7 shows the circuit traces that require additional layout consideration. Use single point and ground plane construction for the circuits shown. Minimize any leakage current paths on the SS PIN and locate the capacitor,  $C_{SS}$  close to the SS pin because the internal current source is only 10 $\mu$ A. Provide local  $V_{CC}$  decoupling between  $V_{CC}$  and GND pins. Locate the capacitor,  $C_{BOOT}$  as close as practical to the BOOT and PHASE pins.

**Feedback Compensation**

Figure 8 highlights the voltage-mode control loop for a synchronous-rectified buck converter. The output voltage ( $V_{OUT}$ ) is regulated to the Reference voltage level. The error amplifier (Error Amp) output ( $V_{E/A}$ ) is compared with the oscillator (OSC) triangular wave to provide a pulse-width modulated (PWM) wave with an amplitude of  $V_{IN}$  at the PHASE node. The PWM wave is smoothed by the output filter ( $L_O$  and  $C_O$ ).

The modulator transfer function is the small-signal transfer function of  $V_{OUT}/V_{E/A}$ . This function is dominated by a DC Gain and the output filter ( $L_O$  and  $C_O$ ), with a double pole break frequency at  $F_{LC}$  and a zero at  $F_{ESR}$ . The DC Gain of the modulator is simply the input voltage ( $V_{IN}$ ) divided by the peak-to-peak oscillator voltage  $\Delta V_{OSC}$ .

**Modulator Break Frequency Equations**

$$F_{LC} = \frac{1}{2\pi \cdot \sqrt{L_O \cdot C_O}} \quad F_{ESR} = \frac{1}{2\pi \cdot (ESR \cdot C_O)}$$

The compensation network consists of the error amplifier (internal to the HIP6002) and the impedance networks  $Z_{IN}$  and  $Z_{FB}$ . The goal of the compensation network is to provide a closed loop transfer function with the highest 0dB crossing frequency ( $f_{0dB}$ ) and adequate phase margin. Phase margin is the difference between the closed loop phase at  $f_{0dB}$  and 180 degrees. The equations below relate the compensation network's poles, zeros and gain to the components ( $R_1$ ,  $R_2$ ,  $R_3$ ,  $C_1$ ,  $C_2$ , and  $C_3$ ) in Figure 9. Use these guidelines for locating the poles and zeros of the compensation network:

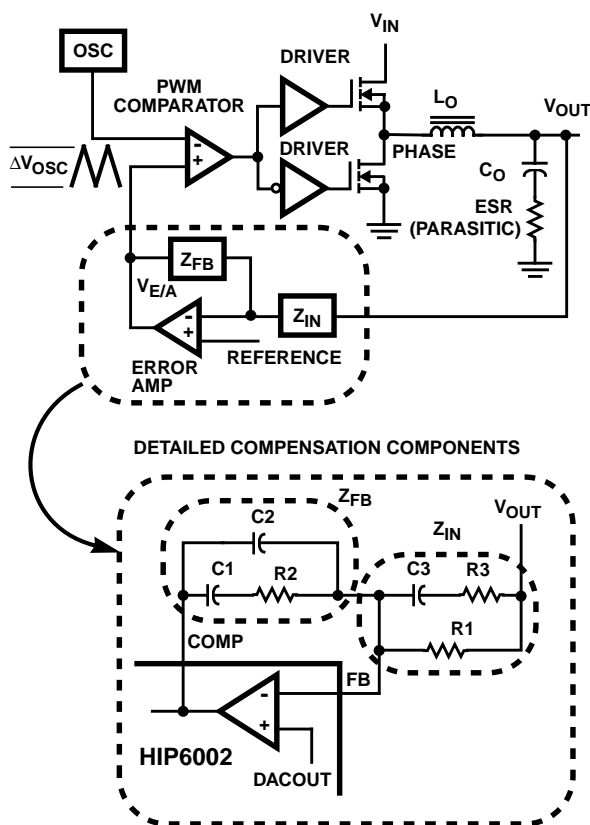

FIGURE 8. VOLTAGE - MODE BUCK CONVERTER COMPENSATION DESIGN

**Compensation Break Frequency Equations**

$$F_{Z1} = \frac{1}{2\pi \cdot R2 \cdot C1} \quad F_{P1} = \frac{1}{2\pi \cdot R2 \cdot \left(\frac{C1 \cdot C2}{C1 + C2}\right)}$$

$$F_{Z2} = \frac{1}{2\pi \cdot (R1 + R3) \cdot C3} \quad F_{P2} = \frac{1}{2\pi \cdot R3 \cdot C3}$$

1. Pick Gain (R2/R1) for desired converter bandwidth
2. Place 1<sup>ST</sup> Zero Below Filter's Double Pole (~75% F<sub>LC</sub>)
3. Place 2<sup>ND</sup> Zero at Filter's Double Pole
4. Place 1<sup>ST</sup> Pole at the ESR Zero
5. Place 2<sup>ND</sup> Pole at Half the Switching Frequency
6. Check Gain against Error Amplifier's Open-Loop Gain
7. Estimate Phase Margin - Repeat if Necessary

Figure 9 shows an asymptotic plot of the DC-DC converter's gain vs frequency. The actual Modulator Gain has a high gain peak due to the high Q factor of the output filter and is not shown in Figure 9. Using the above guidelines should give a Compensation Gain similar to the curve plotted. The open loop error amplifier gain bounds the compensation gain. Check the compensation gain at F<sub>P2</sub> with the capabilities of the error amplifier. The Closed Loop Gain is constructed on the log-log graph of Figure 9 by adding the Modulator Gain (in dB) to the Compensation Gain (in dB). This is equivalent to

multiplying the modulator transfer function to the compensation transfer function and plotting the gain.

The compensation gain uses external impedance networks Z<sub>FB</sub> and Z<sub>IN</sub> to provide a stable, high bandwidth (BW) overall loop. A stable control loop has a gain crossing with -20dB/decade slope and a phase margin greater than 45 degrees. Include worst case component variations when determining phase margin.

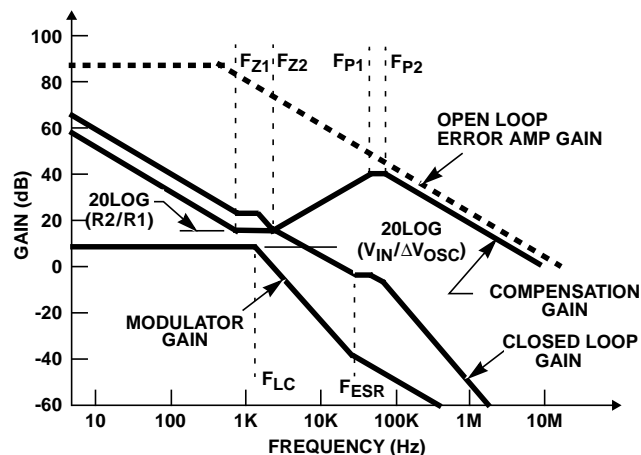

FIGURE 9. ASYMPTOTIC BODE PLOT OF CONVERTER GAIN

**Component Selection Guidelines**

**Output Capacitor Selection**

An output capacitor is required to filter the output and supply the load transient current. The filtering requirements are a function of the switching frequency and the ripple current. The load transient requirements are a function of the slew rate (di/dt) and the magnitude of the transient load current. These requirements are generally met with a mix of capacitors and careful layout.

Modern microprocessors produce transient load rates above 1A/ns. High frequency capacitors initially supply the transient and slow the current load rate seen by the bulk capacitors. The bulk filter capacitor values are generally determined by the ESR (effective series resistance) and voltage rating requirements rather than actual capacitance requirements.

High frequency decoupling capacitors should be placed as close to the power pins of the load as physically possible. Be careful not to add inductance in the circuit board wiring that could cancel the usefulness of these low inductance components. Consult with the manufacturer of the load on specific decoupling requirements. For example, Intel recommends that the high frequency decoupling for the Pentium Pro be composed of at least forty (40) 1μF ceramic capacitors in the 1206 surface-mount package.

Use only specialized low-ESR capacitors intended for switching-regulator applications for the bulk capacitors. The

bulk capacitor's ESR will determine the output ripple voltage and the initial voltage drop after a high slew-rate transient. An aluminum electrolytic capacitor's ESR value is related to the case size with lower ESR available in larger case sizes. However, the Equivalent Series Inductance (ESL) of these capacitors increases with case size and can reduce the usefulness of the capacitor to high slew-rate transient loading. Unfortunately, ESL is not a specified parameter. Work with your capacitor supplier and measure the capacitor's impedance with frequency to select a suitable component. In most cases, multiple electrolytic capacitors of small case size perform better than a single large case capacitor.

### Output Inductor Selection

The output inductor is selected to meet the output voltage ripple requirements and minimize the converter's response time to the load transient. The inductor value determines the converter's ripple current and the ripple voltage is a function of the ripple current. The ripple voltage and current are approximated by the following equations:

$$\Delta I = \frac{V_{IN} - V_{OUT}}{F_s \times L} \cdot \frac{V_{OUT}}{V_{IN}} \quad \Delta V_{OUT} = \Delta I \times ESR$$

Increasing the value of inductance reduces the ripple current and voltage. However, the large inductance values reduce the converter's response time to a load transient.

One of the parameters limiting the converter's response to a load transient is the time required to change the inductor current. Given a sufficiently fast control loop design, the HIP6002 will provide either 0% or 100% duty cycle in response to a load transient. The response time is the time required to slew the inductor current from an initial current value to the transient current level. During this interval the difference between the inductor current and the transient current level must be supplied by the output capacitor. Minimizing the response time can minimize the output capacitance required.

The response time to a transient is different for the application of load and the removal of load. The following equations give the approximate response time interval for application and removal of a transient load:

$$t_{RISE} = \frac{L_O \times I_{TRAN}}{V_{IN} - V_{OUT}} \quad t_{FALL} = \frac{L_O \times I_{TRAN}}{V_{OUT}}$$

where:  $I_{TRAN}$  is the transient load current step,  $t_{RISE}$  is the response time to the application of load, and  $t_{FALL}$  is the response time to the removal of load. With a +5V input source, the worst case response time can be either at the application or removal of load and dependent upon the DACOUT setting. Be sure to check both of these equations at the minimum and maximum output levels for the worst case response time. With a +12V input, and output voltage level equal to DACOUT,  $t_{FALL}$  is the longest response time.

### Input Capacitor Selection

Use a mix of input bypass capacitors to control the voltage overshoot across the MOSFETs. Use small ceramic capacitors for high frequency decoupling and bulk capacitors to supply the current needed each time Q1 turns on. Place the small ceramic capacitors physically close to the MOSFETs and between the drain of Q1 and the source of Q2.

The important parameters for the bulk input capacitor are the voltage rating and the RMS current rating. For reliable operation, select the bulk capacitor with voltage and current ratings above the maximum input voltage and largest RMS current required by the circuit. The capacitor voltage rating should be at least 1.25 times greater than the maximum input voltage and a voltage rating of 1.5 times is a conservative guideline. The RMS current rating requirement for the input capacitor of a buck regulator is approximately 1/2 the DC load current.

For a through hole design, several electrolytic capacitors (Panasonic HFQ series or Nichicon PL series or Sanyo MV-GX or equivalent) may be needed. For surface mount designs, solid tantalum capacitors can be used, but caution must be exercised with regard to the capacitor surge current rating. These capacitors must be capable of handling the surge-current at power-up. The TPS series available from AVX, and the 593D series from Sprague are both surge current tested.

### MOSFET Selection/Considerations

The HIP6002 requires 2 N-channel power MOSFETs. These should be selected based upon  $r_{DS(ON)}$ , gate supply requirements, and thermal management requirements.

In high-current applications, the MOSFET power dissipation, package selection and heatsink are the dominant design factors. The power dissipation includes two loss components; conduction loss and switching loss. The conduction losses are the largest component of power dissipation for both the upper and the lower MOSFETs. These losses are distributed between the two MOSFETs according to duty factor (see the equations below). Only the upper MOSFET has switching losses, since the Schottky rectifier clamps the switching node before the synchronous rectifier turns on. These equations assume linear

$$P_{UPPER} = I_O^2 \times r_{DS(ON)} \times D + \frac{1}{2} I_O \times V_{IN} \times t_{SW} \times F_s$$

$$P_{LOWER} = I_O^2 \times r_{DS(ON)} \times (1 - D)$$

Where: D is the duty cycle =  $V_{OUT}/V_{IN}$ ,  
 $t_{SW}$  is the switching interval, and  
 $F_s$  is the switching frequency.

voltage-current transitions and do not adequately model power loss due the reverse-recovery of the lower MOSFET's body diode. The gate-charge losses are dissipated by the HIP6002 and don't heat the MOSFETs. However, large gate-charge increases the switching interval,  $t_{SW}$  which increases

the upper MOSFET switching losses. Ensure that both MOSFETs are within their maximum junction temperature at high ambient temperature by calculating the temperature rise according to package thermal-resistance specifications. A separate heatsink may be necessary depending upon MOSFET power, package type, ambient temperature and air flow.

Standard-gate MOSFETs are normally recommended for use with the HIP6002. However, logic-level gate MOSFETs can be used under special circumstances. The input voltage, upper gate drive level, and the MOSFET's absolute gate-to-source voltage rating determine whether logic-level MOSFETs are appropriate.

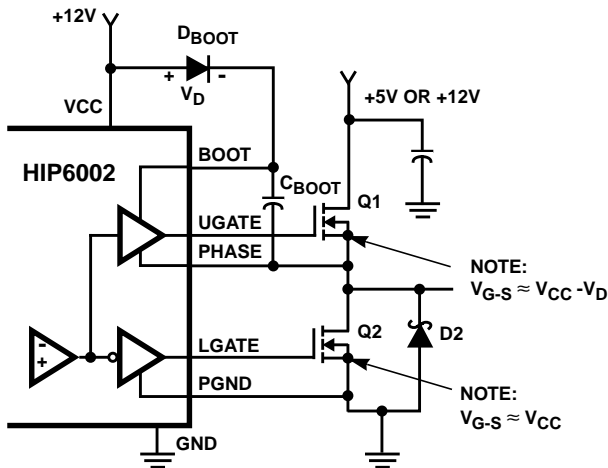

FIGURE 10. UPPER GATE DRIVE - BOOTSTRAP OPTION

Figure 10 shows the upper gate drive (BOOT pin) supplied by a bootstrap circuit from  $V_{CC}$ . The boot capacitor,  $C_{BOOT}$  develops a floating supply voltage referenced to the PHASE pin. This supply is refreshed each cycle to a voltage of  $V_{CC}$  less the boot diode drop ( $V_D$ ) when the lower MOSFET, Q2 turns on. Logic-level MOSFETs can only be used if the MOSFET's absolute gate-to-source voltage rating exceeds the maximum voltage applied to  $V_{CC}$ .

Figure 11 shows the upper gate drive supplied by a direct connection to  $V_{CC}$ . This option should only be used in converter systems where the main input voltage is +5 VDC or less. The peak upper gate-to-source voltage is approximately  $V_{CC}$  less the input supply. For +5V main power and +12 VDC for the bias, the gate-to-source voltage of Q1 is 7V. A logic-level MOSFET is a good choice for Q1 and a logic-level MOSFET can be used for Q2 if its absolute gate-to-source voltage rating exceeds the maximum voltage applied to  $V_{CC}$ .

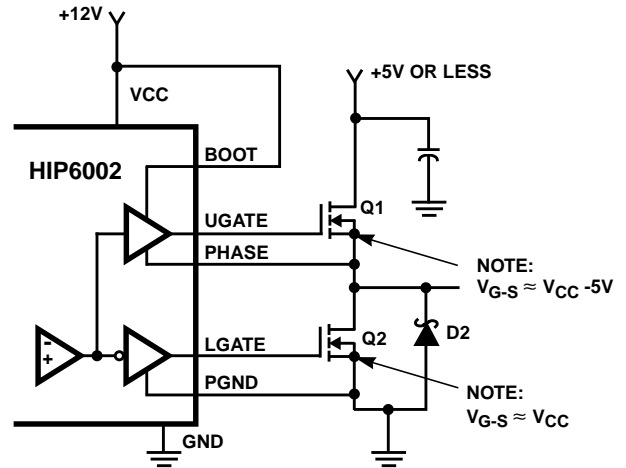

FIGURE 11. UPPER GATE DRIVE - DIRECT  $V_{CC}$  DRIVE OPTION

**Schottky Selection**

Rectifier D2 is a clamp that catches the negative inductor swing during the dead time between turning off the lower MOSFET and turning on the upper MOSFET. The diode must be a Schottky type to prevent the lossy parasitic MOSFET body diode from conducting. It is acceptable to omit the diode and let the body diode of the lower MOSFET clamp the negative inductor swing, but efficiency will drop one or two percent as a result. The diode's rated reverse breakdown voltage must be greater than the maximum input voltage.

**HIP6002 DC-DC Converter Application Circuit**

Figure 12 shows an application circuit of a DC-DC Converter for an Intel Pentium Pro microprocessor. Detailed information on the circuit, including a complete Bill-of-Materials and circuit board description, can be found in Application Note AN9668. See Intersil's home page on the web: [www.intersil.com](http://www.intersil.com) or Intersil AnswerFAX (321-724-7800) document # 99668.

# HIP6002

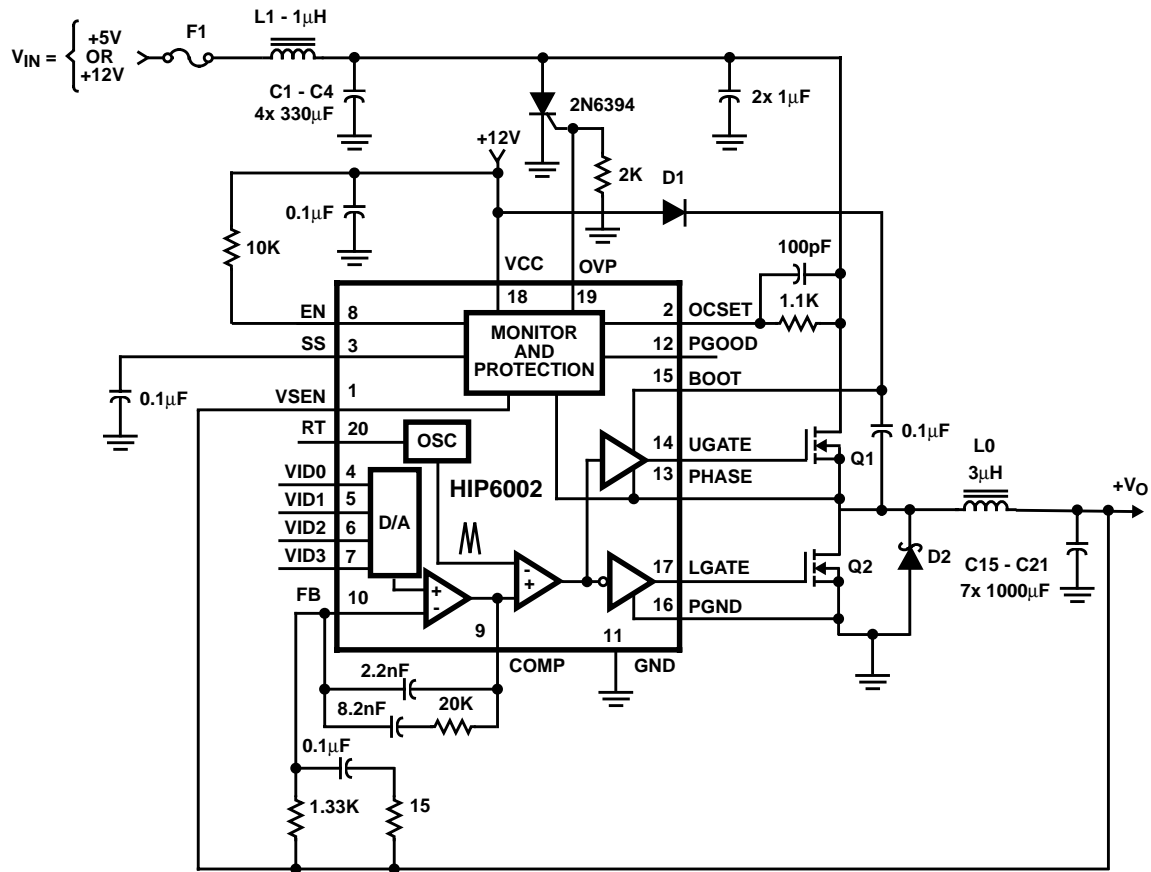

**Component Selection Notes:**

- C15 - C21 each 1000µF 6.3W VDC, Sanyo MV-GX or Equivalent.
- C1 - C4 each 330µF 25W VDC, Sanyo MV-GX or Equivalent.
- L0 - Core: Micrometals T50-52B; Each Winding: 10 Turns of 16AWG.
- L1 - Core: Micrometals T50-52; Winding: 5 Turns of 18AWG.
- D1 - 1N4148 or Equivalent.
- D2 - 3A, 40V Schottky, Motorola MBR340 or Equivalent.
- Q1 - Q2 - Intersil MOSFET; RFP70N03.

**FIGURE 12. PENTIUM PRO DC-DC CONVERTER**

**Small Outline Plastic Packages (SOIC)**

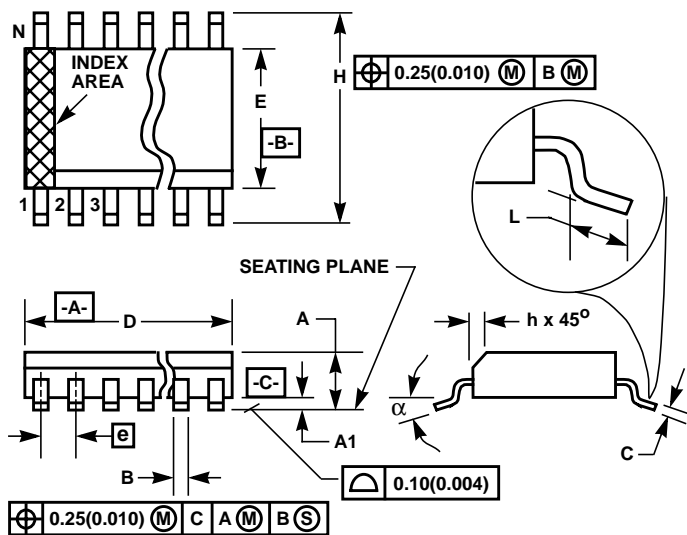

**M20.3 (JEDEC MS-013-AC ISSUE C)  
20 LEAD WIDE BODY SMALL OUTLINE PLASTIC PACKAGE**

SYMBOL	INCHES		MILLIMETERS		NOTES
	MIN	MAX	MIN	MAX	
A	0.0926	0.1043	2.35	2.65	-
A1	0.0040	0.0118	0.10	0.30	-
B	0.013	0.0200	0.33	0.51	9
C	0.0091	0.0125	0.23	0.32	-
D	0.4961	0.5118	12.60	13.00	3
E	0.2914	0.2992	7.40	7.60	4
e	0.050 BSC		1.27 BSC		-
H	0.394	0.419	10.00	10.65	-
h	0.010	0.029	0.25	0.75	5
L	0.016	0.050	0.40	1.27	6
N	20		20		7
alpha	0°	8°	0°	8°	-

**NOTES:**

1. Symbols are defined in the "MO Series Symbol List" in Section 2.2 of Publication Number 95.
2. Dimensioning and tolerancing per ANSI Y14.5M-1982.
3. Dimension "D" does not include mold flash, protrusions or gate burrs. Mold flash, protrusion and gate burrs shall not exceed 0.15mm (0.006 inch) per side.
4. Dimension "E" does not include interlead flash or protrusions. Interlead flash and protrusions shall not exceed 0.25mm (0.010 inch) per side.
5. The chamfer on the body is optional. If it is not present, a visual index feature must be located within the crosshatched area.
6. "L" is the length of terminal for soldering to a substrate.
7. "N" is the number of terminal positions.
8. Terminal numbers are shown for reference only.
9. The lead width "B", as measured 0.36mm (0.014 inch) or greater above the seating plane, shall not exceed a maximum value of 0.61mm (0.024 inch)
10. Controlling dimension: MILLIMETER. Converted inch dimensions are not necessarily exact.

Rev. 0 12/93

All Intersil semiconductor products are manufactured, assembled and tested under **ISO9000** quality systems certification.

*Intersil semiconductor products are sold by description only. Intersil Corporation reserves the right to make changes in circuit design and/or specifications at any time without notice. Accordingly, the reader is cautioned to verify that data sheets are current before placing orders. Information furnished by Intersil is believed to be accurate and reliable. However, no responsibility is assumed by Intersil or its subsidiaries for its use; nor for any infringements of patents or other rights of third parties which may result from its use. No license is granted by implication or otherwise under any patent or patent rights of Intersil or its subsidiaries.*

For information regarding Intersil Corporation and its products, see web site [www.intersil.com](http://www.intersil.com)

**Sales Office Headquarters**

**NORTH AMERICA**

Intersil Corporation  
P. O. Box 883, Mail Stop 53-204  
Melbourne, FL 32902  
TEL: (321) 724-7000  
FAX: (321) 724-7240

**EUROPE**

Intersil SA  
Mercure Center  
100, Rue de la Fusee  
1130 Brussels, Belgium  
TEL: (32) 2.724.2111  
FAX: (32) 2.724.22.05

**ASIA**

Intersil (Taiwan) Ltd.  
7F-6, No. 101 Fu Hsing North Road  
Taipei, Taiwan  
Republic of China  
TEL: (886) 2 2716 9310  
FAX: (886) 2 2715 3029

This datasheet has been downloaded from:

[www.DatasheetCatalog.com](http://www.DatasheetCatalog.com)

Datasheets for electronic components.



LittleDiode supplies new, hard to find or obsolete electronic components and semiconductors all over the world.

With over two million different components listed you are sure to find the part you need.

Feel free to visit us today at our online store:

[LittleDiode.com](http://LittleDiode.com)

Looking forward to providing you with the best possible service.