

DATA SHEET

hitag

HTRC11001T HITAG reader chip

Product specification
Supersedes data of 1999 Jan 01
File under Integrated Circuits, IC11

2001 Nov 23

HITAG reader chip**HTRC11001T**

CONTENTS	13	PACKAGE OUTLINE
1	14	SOLDERING
2	14.1	Introduction to soldering surface mount packages
3	14.2	Reflow soldering
4	14.3	Wave soldering
5	14.4	Manual soldering
6	14.5	Suitability of surface mount IC packages for wave and reflow soldering methods
7	15	DATA SHEET STATUS
8	16	DEFINITIONS
8.1	17	DISCLAIMERS
8.2		
8.3		
8.4		
8.5		
8.6		
8.7		
8.7.1		
8.7.2		
8.8		
8.8.1		
8.8.2		
8.8.3		
8.8.4		
8.8.5		
8.8.6		
8.8.7		
8.8.8		
9		
10		
11		
12		

HITAG reader chip

HTRC11001T



1 FEATURES

- Combines all analog RFID reader hardware in one single chip
- Optimized for HITAG transponder family
- Robust antenna coil power driver stage with modulator
- High performance adaptive sampling time AM/PM demodulator (patent pending)
- Read and write function
- On-chip clock oscillator
- Antenna rupture and short circuit detection
- Low power consumption
- Very low power standby mode
- Low external component count
- Small package SO14.

2 APPLICATIONS

- RFID systems.

3 GENERAL DESCRIPTION

HITAG⁽¹⁾ is the family name of the reader chip HTRC11001T to use with transponders which are based on the HITAG tag ICs (HT1ICS3002x or HT2ICS2002x).

(1) HITAG - is a trademark of Philips Semiconductors Gratkorn GmbH.

The receiver parameters (gain factors and filter cut-off frequencies) can be optimized to system and transponder requirements. The HTRC11001T is designed for easy integration into RF identification readers.

State-of-the-art technology allows almost complete integration of the necessary building blocks. A powerful antenna demodulator and driver, together with a low-noise adaptive sampling time demodulator, a programmable filter, amplifier and digitizer, build the complete transceiver unit, required to design high-performance readers.

A three-pin microcontroller interface is employed for programming the HTRC11001T as well as for the bidirectional communication with the transponders. The three-wire interface can be changed into a two-wire interface by connecting the data input and the data output.

Tolerance dependent zero amplitude modulation will cause severe problems in envelope detector systems, resulting in the need of very low tolerance reader antennas. These problems are solved by the new Adaptive Sampling Time (AST) technique.

4 QUICK REFERENCE DATA

SYMBOL	PARAMETER	CONDITIONS	MIN.	TYP.	MAX.	UNIT
V_{DD}	supply voltage		4.5	5.0	5.5	V
f_{clk}	clock frequency	programmable	4	–	16	MHz
f_{res}	antenna resonant frequency		–	125	–	kHz
$I_{ant(p)}$	antenna driver output current (peak value)	continuous	–	–	200	mA
T_{amb}	ambient temperature		–40	–	+85	°C

5 ORDERING INFORMATION

TYPE NUMBER	PACKAGE		
	NAME	DESCRIPTION	VERSION
HTRC11001T	SO14	plastic small outlet package; 14 leads; body width 3.9 mm	SOT108-1

HITAG reader chip

HTRC11001T

6 BLOCK DIAGRAM

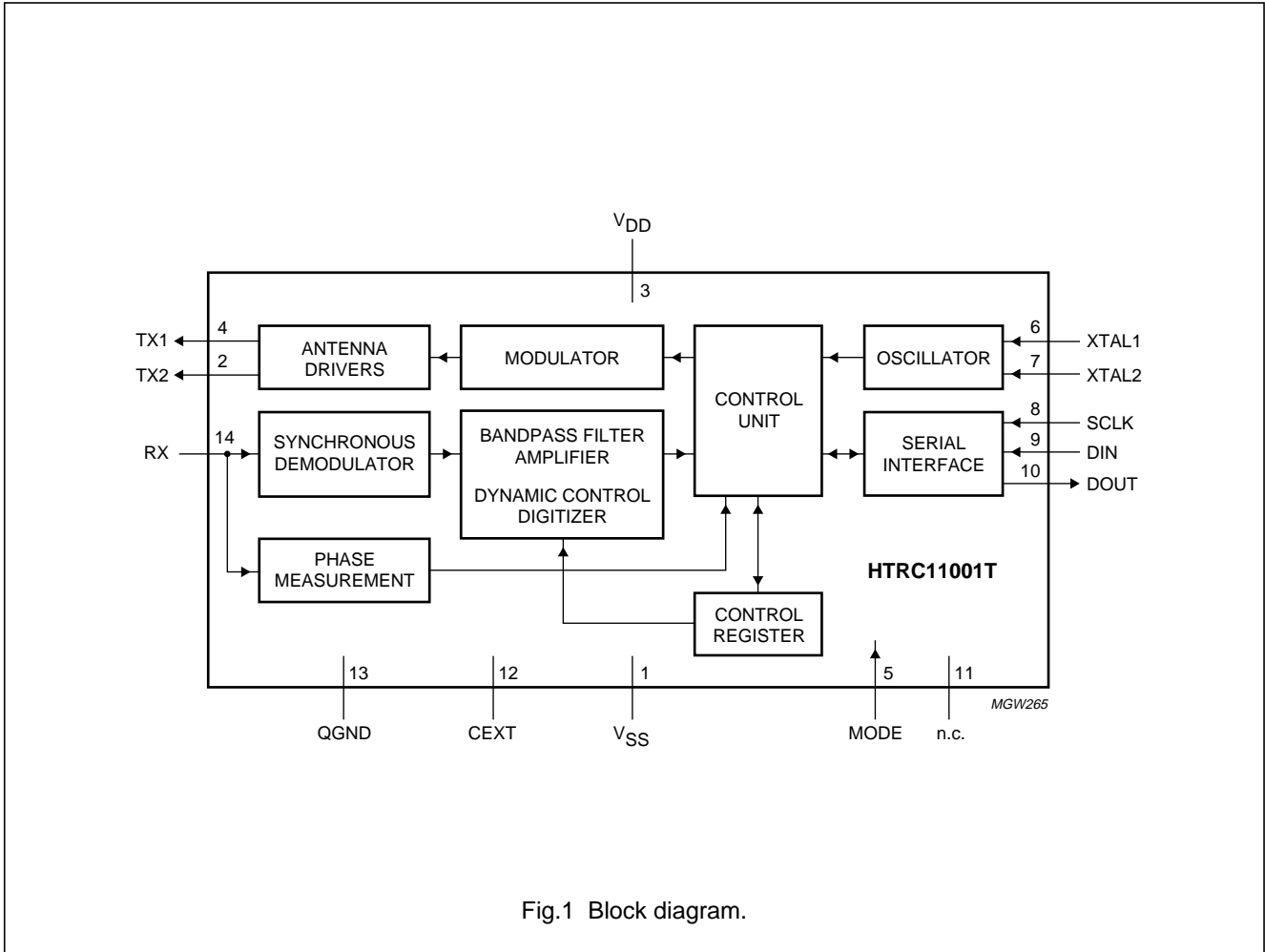

Fig.1 Block diagram.

HITAG reader chip

HTRC11001T

7 PINNING

SYMBOL	PIN	DESCRIPTION
V _{SS}	1	ground supply
TX2	2	antenna driver output 2
V _{DD}	3	supply voltage (5 V stabilized)
TX1	4	antenna driver output 1
MODE	5	control input to enable filtering of serial clock and data input; for active antenna applications
XTAL1	6	oscillator input 1
XTAL2	7	oscillator input 2
SCLK	8	serial clock input of microcontroller interface
DIN	9	serial data input of microcontroller interface
DOUT	10	serial data output of microcontroller interface
n.c.	11	not connected
CEXT	12	high-pass filter coupling capacitor connection
QGND	13	internal analog virtual ground capacitor connection
RX	14	demodulator input

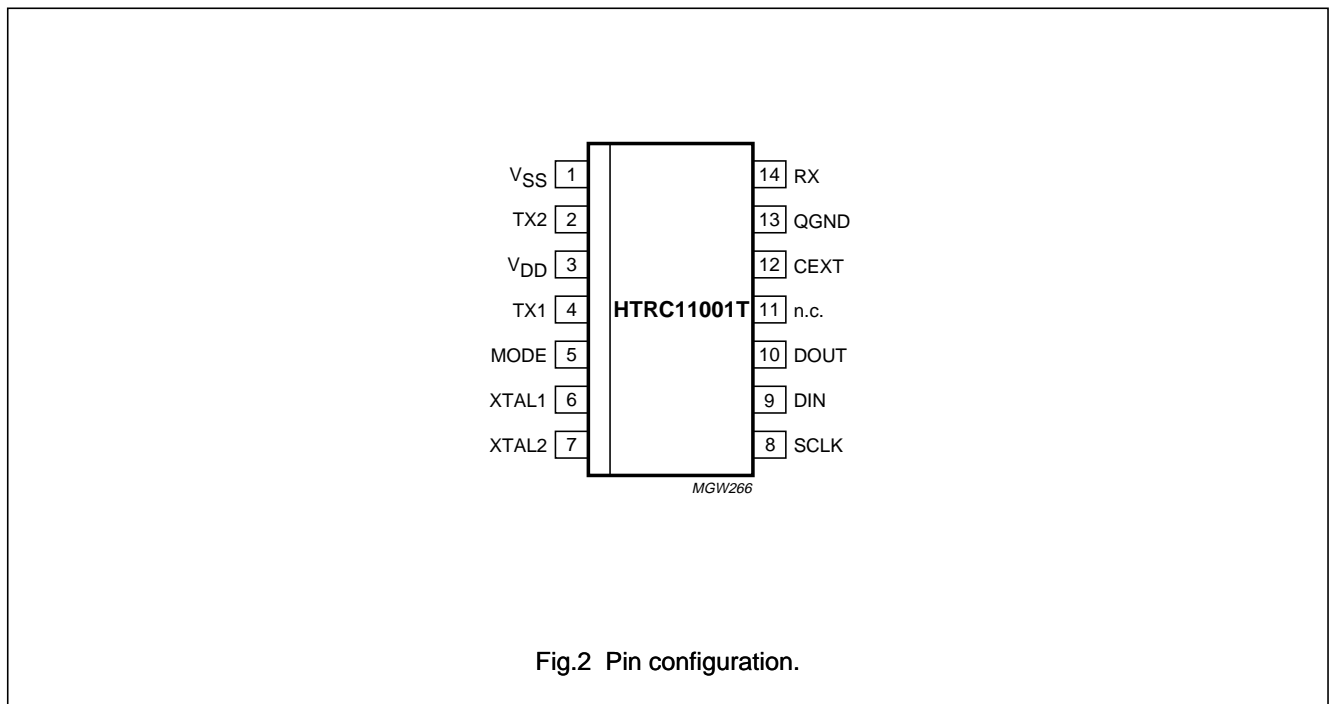

HITAG reader chip

HTRC11001T

8 FUNCTIONAL DESCRIPTION

8.1 Power supply

The HTRC11001T works with an external 5 V $\pm 10\%$ power supply at pin V_{DD}. The maximum DC current is

$$10 \text{ mA} + \frac{2}{\pi} \times I_{\text{ant(p)}} = 137 \text{ mA.}$$

For optimum performance, the power supply connection should be bypassed to ground with a 100 nF capacitor close to the chip.

8.2 Antenna drivers

The drivers deliver a square shaped voltage to the series resonant antenna circuit (see Fig.4). Due to the full bridge configuration of the drivers the output voltage V_{ant(p-p)} is approximately 10 V, corresponding to V_{ant(p)} = 5 V. The current flowing through the antenna is sine shaped and the peak and RMS values are approximately:

$$I_{\text{ant(p)}} = \frac{4}{\pi} \times \frac{V_{\text{ant(p)}}}{R_{\text{ant}}}$$

$$I_{\text{ant(rms)}} = \frac{1}{\sqrt{2}} \times I_{\text{ant(p)}}$$

8.3 Diagnosis

In order to detect an antenna short-circuit or open-circuit the antenna tap voltage is monitored.

An antenna fail condition is reported in the status bit ANTFAIL (see Table 5) if the antenna tap voltage does not go more negative than the diagnosis level voltage (V_{diag} = -1.15 V). This condition is checked for every coil driver cycle.

8.4 Oscillator with programmable divider

The crystal oscillator at pins XTAL1 and XTAL2 works with either crystal or ceramic resonators. It delivers the input clock frequency of 4, 8, 12 or 16 MHz. The oscillator frequency is divided by a programmable divider (selection bits FSEL1 and FSEL0) to obtain the carrier frequency of 125 kHz (see Table 3).

Alternatively, an external clock signal (CMOS compatible) may be connected to pin XTAL1. For example, this clock signal can be derived from the microcontroller clock.

8.5 Adaptive sampling time demodulator

The demodulator senses the absorption modulation applied by a transponder when inserted into the field. The signal is picked up at the antenna tap point between L_a and C_a. It is divided by R_v and the internal resistor R_{int} to a level on pin RX below 8 V (peak value) with respect to pin QGND (see Fig.4). Internally the signal is filtered with a second-order low-pass filter.

The antenna current and therefore the tap voltage is modulated by the transponder in amplitude and/or phase. This signal is fed into a synchronous demodulator recovering the baseband signal. The amplification and the bandpass filter edge frequencies of the demodulator can be adapted to different transponders via settings in the configuration pages (see Table 3).

The phase between the driver excitation signal and the antenna tap voltage depends on the antenna tuning. With optimum tuning, the phase of the antenna tap voltage is 90° off the antenna driver signal. Detuning of the antenna resonant circuit results in a change of this phase relationship. The built-in phase measurement unit allows the measurement of this phase relationship with a

resolution of $\frac{1}{64} \times 360^\circ = 5.625^\circ$. This can be used to

compute a sampling time that compensates the detuning of the reader antenna.

The phase measurement procedure can be carried out:

- Once before the first communication starts, if the position of the transponder does not change with respect to the reader antenna
- During the communication (after sending the write pulses and before receiving the answer of the transponder), if the tag is moving.

Before the system is switched into WRITE_TAG mode, the demodulator has to be frozen. This is internally done by clamping the input of the filter amplifier unit to the level on pin QGND. Doing so avoids large transients in the amplifier and digitizer, which could affect settling times. In addition to the clamping, there exist other means in the HTRC11001T which allow further reduction of the settling times. All the parts of the circuitry which are associated with these functions are controlled by the bits FREEZE0, FREEZE1 and THRESE1 (see Table 2).

For more details concerning write timing, demodulator setting, power-up sequence, etc. please refer to the application note "AN 98080 Read/Write devices based on the HITAG Read/Write IC HTRC110".

HITAG reader chip

HTRC11001T

8.6 Idle and Power-down mode

The HTRC11001T can be switched into the Idle mode via setting bit PD = 1 and resetting bit PD_MODE = 0 (see Table 3). In this Idle mode, only the oscillator and a few other system components are active.

It is also possible to switch the HTRC11001T completely off. This is achieved by the Power-down mode (bit PD = 1 and bit PD_MODE = 1). Within this mode also the clock oscillator is switched off. This reduces the supply current of the HTRC11001T to less than 20 μ A.

8.7 Serial interface

The communication between the HTRC11001T and the microcontroller is done via a 3-wire digital interface. The interface is operated by the following signals:

- Clock pulse on pin SCLK
- Data input on pin DIN
- Data output on pin DOUT.

Pins SCLK and DIN are realized as Schmitt-trigger inputs. Pin DOUT is an open-drain output with an internal pull-up resistor.

8.7.1 COMMUNICATION PROTOCOL

Every communication between the HTRC11001T and the microcontroller begins with an initialization of the serial interface. The interface initialization condition is a LOW-to-HIGH transition on pin DIN while pin SCLK is at HIGH level (see Fig.3).

All commands transmitted to the HTRC11001T serial interface start with the Most Significant Bit (MSB).

Input DIN and output DOUT are valid when pin SCLK is at HIGH level.

8.7.2 GLITCH FILTER

Connecting pin MODE to V_{DD} enables digital filtering of the SCLK and the DIN input signals. This mode offers improved immunity against noise and interference (glitches) on these interface signals. It is intended to be used in the so called 'active antenna applications' where the microcontroller and the reader communicate via long signal lines (e.g. 1 meter).

In other applications pin MODE has to be connected to ground (pin V_{SS}).

For a detailed description of this feature, refer to the application note "AN 98080 Read/Write devices based on the HITAG Read/Write IC HTRC110".

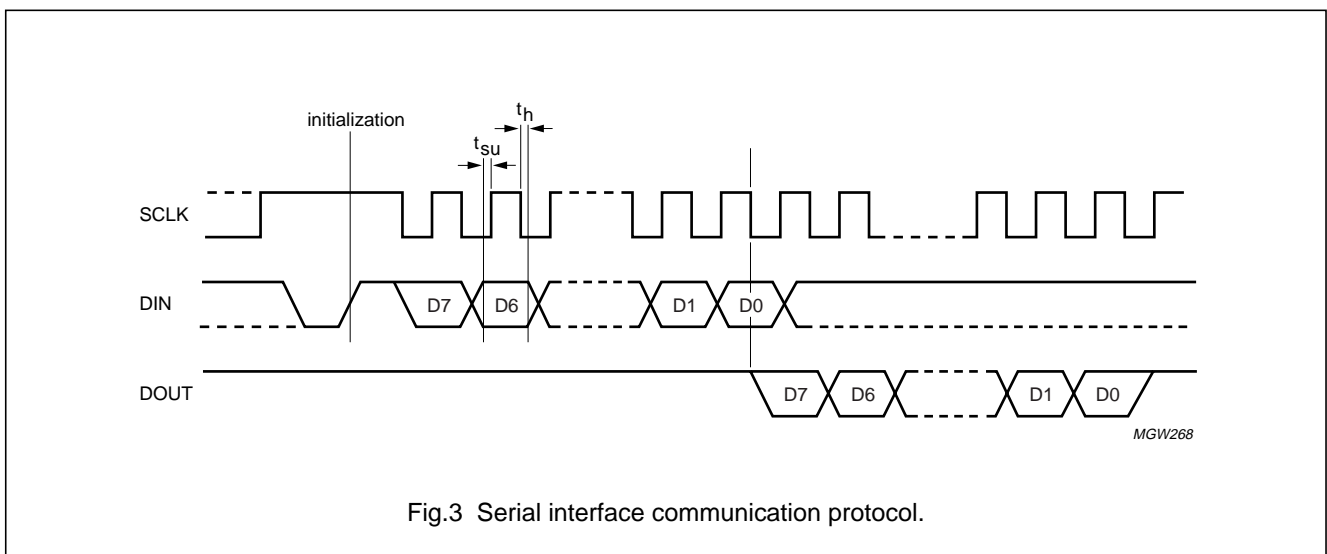

Fig.3 Serial interface communication protocol.

HITAG reader chip

HTRC11001T

8.8 Commands

Table 1 Summary of the HTRC11001T command set

COMMAND NAME	BIT 7 MSB	BIT 6	BIT 5	BIT 4	BIT 3	BIT 2	BIT 1	BIT 0 LSB	REMARK
READ_TAG	1	1	1	–	–	–	–	–	READ_TAG mode
WRITE_TAG_N	0	0	0	1	N3	N2	N1	N0	WRITE_TAG mode with pulse width programming
WRITE_TAG	1	1	0	–	–	–	–	–	WRITE_TAG mode
READ_PHASE	0	0	0	0	1	0	0	0	read command
	0	0	D5	D4	D3	D2	D1	D0	response
SET_SAMPLING_TIME	1	0	D5	D4	D3	D2	D1	D0	
GET_SAMPLING_TIME	0	0	0	0	0	0	1	0	read command
	0	0	D5	D4	D3	D2	D1	D0	response
SET_CONFIG_PAGE	0	1	P1	P0	D3	D2	D1	D0	4 × 4 configuration bits available
GET_CONFIG_PAGE	0	0	0	0	0	1	P1	P0	read command
	X3	X2	X1	X0	D3	D2	D1	D0	response

8.8.1 COMMAND READ_TAG

NAME	BIT 7	BIT 6	BIT 5	BIT 4	BIT 3	BIT 2	BIT 1	BIT 0
Command bits	1	1	1	–	–	–	–	–

This command is used to read the demodulated bit stream from a transponder.

After the assertion of the three command bits the HTRC11001T instantaneously switches to the READ_TAG mode and transmits the demodulated, filtered and digitized data to the microcontroller. This data should be decoded by the microcontroller.

The READ_TAG mode is terminated by a LOW-to-HIGH transition on pin SCLK.

8.8.2 COMMAND WRITE_TAG_N

NAME	BIT 7	BIT 6	BIT 5	BIT 4	BIT 3	BIT 2	BIT 1	BIT 0
Command bits	0	0	0	1	N3	N2	N1	N0

This command is used to write data to a transponder.

If bits N3 to N0 are set to 0000, the signal on pin DIN is transparently switched to the drivers. A HIGH level on pin DIN corresponds to antenna drivers switched off and a LOW level corresponds to antenna drivers switched on.

For any binary number N between 0001 and 1111, the drivers are switched off at the next positive transition on pin DIN. This state is held for a time interval $t = N \times T_0$ (for $T_0 = 8 \mu\text{s}$). This method relaxes the timing resolution requirements to the microcontroller and to the software implementation while providing an exact, selectable write pulse timing.

The WRITE_TAG mode is terminated immediately by a LOW- to-HIGH transition on pin SCLK.

HITAG reader chip

HTRC11001T

8.8.3 COMMAND WRITE_TAG

NAME	BIT 7	BIT 6	BIT 5	BIT 4	BIT 3	BIT 2	BIT 1	BIT 0
Command bits	1	1	0	–	–	–	–	–

This is the 3-bit short form of the previously described command WRITE_TAG_N. It allows to switch into the WRITE_TAG mode with a minimum communication time.

The behaviour of the WRITE_TAG command is identical to WRITE_TAG_N with two exceptions:

- WRITE_TAG mode is entered after assertion of the third command bit
- No N parameter is specified with this command; instead the N value which was programmed with the most recent WRITE_TAG_N command is used. If no WRITE_TAG_N was issued so far, a default N = 0 (transparent mode) will be assumed.

8.8.4 COMMAND READ_PHASE

NAME	BIT 7	BIT 6	BIT 5	BIT 4	BIT 3	BIT 2	BIT 1	BIT 0
Command bits	0	0	0	0	1	0	0	0
Response bits	0	0	D5	D4	D3	D2	D1	D0

This command is used to read the antenna phase, which is measured at every carrier cycle.

The response bits D5 to D0 represent the phase (coded binary).

8.8.5 COMMAND SET_SAMPLING_TIME

NAME	BIT 7	BIT 6	BIT 5	BIT 4	BIT 3	BIT 2	BIT 1	BIT 0
Command bits	1	0	D5	D4	D3	D2	D1	D0

This command specifies the demodulator sampling time t_s . The sampling time is coded binary in bits D5 to D0.

8.8.6 COMMAND GET_SAMPLING_TIME

NAME	BIT 7	BIT 6	BIT 5	BIT 4	BIT 3	BIT 2	BIT 1	BIT 0
Command bits	0	0	0	0	0	0	1	0
Response bits	0	0	D5	D4	D3	D2	D1	D0

This command is used to read back the sampling time t_s set with SET_SAMPLING_TIME.

The response bits D5 to D0 represent the sampling time (coded binary).

HITAG reader chip

HTRC11001T

8.8.7 COMMAND SET_CONFIG_PAGE

NAME	BIT 7	BIT 6	BIT 5	BIT 4	BIT 3	BIT 2	BIT 1	BIT 0
Command	0	1	P1	P0	D3	D2	D1	D0

This command is used to set the filter and amplifier parameters (cut-off frequencies and gain factors) and to select the operation mode. Bits P1 and P0 select one of four configuration pages.

Table 2 Configuration page bit names

COMMAND PAGE NUMBER	BIT							
	7	6	P1	P0	D3	D2	D1	D0
SET_CONFIG_PAGE 0	0	1	0	0	GAIN1	GAIN0	FILTERH	FILTERL
SET_CONFIG_PAGE 1	0	1	0	1	PD_MODE	PD	HYSTERESIS	TXDIS
SET_CONFIG_PAGE 2	0	1	1	0	THRESET	ACQAMP	FREEZE1	FREEZE0
SET_CONFIG_PAGE 3	0	1	1	1	DISLP1	DISSMART-COMP	FSEL1	FSEL0

Table 3 Description of the configuration page bits

BIT NAME	VALUE	DESCRIPTION	INITIAL VALUE
FILTERL	0	main low-pass cut-off frequency $f_L = 3$ kHz	0
	1	$f_L = 6$ kHz	
FILTERH	0	main high-pass cut-off frequency $f_H = 40$ kHz	0
	1	$f_H = 160$ kHz	
GAIN0	0	amplifier 0 gain factor gain = 16	0
	1	gain = 32	
GAIN1	0	amplifier 1 gain factor gain = 6.22	1
	1	gain = 31.5	
TXDIS	0	disable coil driver coil driver active	0
	1	coil driver inactive	
HYSTERESIS	0	data comparator hysteresis hysteresis OFF	0
	1	hysteresis ON	
PD	0	Power-down mode enable device active	0
	1	device power-down	

HITAG reader chip

HTRC11001T

BIT NAME	VALUE	DESCRIPTION	INITIAL VALUE
PD_MODE	0	select Power-down mode Idle mode	0
	1	Power-down mode	
FREEZE1, FREEZE0	00	facility to achieve fast settling times (MSB and LSB) normal operation	00
	01	main low-pass is frozen; main high-pass is pre-charged to level on pin QGND	
	10	main low-pass is frozen; time constant of main high-pass is reduced by a factor of 16 for bit FILTERH = 0 and by a factor of 8 for bit FILTERH = 1	
	11	main high-pass time constant is reduced by a factor of 16 for bit FILTERH = 0 and by a factor of 8 for bit FILTERH = 1; second high-pass is pre-charged	
ACQAMP	0	store signal amplitude (see also bit AMPCOMP in Table 5) set status bit AMPCOMP when the actual data signal amplitude is higher than the stored reference	0
	1	store actual amplitude of the data signal as reference for later amplitude comparison	
THRESET	0	reset threshold generation of digitizer no reset	0
	1	reset	
FSEL1, FSEL0	00	clock frequency selection (MSB and LSB) 4 MHz	00
	01	8 MHz	
	10	12 MHz	
	11	16 MHz	
DISSMART-COMP	0	disable smart comparator smart comparator: on	0
	1	smart comparator: off	
DISLP1	0	disable low-pass 1 low-pass: on	0
	1	low-pass: off	

HITAG reader chip

HTRC11001T

8.8.8 COMMAND GET_CONFIG_PAGE

NAME	BIT 7	BIT 6	BIT 5	BIT 4	BIT 3	BIT 2	BIT 1	BIT 0
Command bits	0	0	0	0	0	1	P1	P0
Response bits	X3	X2	X1	X0	D3	D2	D1	D0

This command has three functions:

1. Reading back the configuration parameters set by command SET_CONFIG_PAGE
2. Reading back the transmit pulse width programmed with command WRITE_TAG_N
3. Reading the system status information.

Bits P1 and P0 select one of four configuration pages.

The response bits (X3 to X0 and D3 to D0) contains the contents of the selected configuration page in its lower nibble.

For page 0 and page 1 the higher nibble reflects the current setting of the transmit pulse width N.

For page 2 and page 3 the system status information is returned in the higher nibble.

Table 4 Configuration page bit names

COMMAND PAGE NUMBER	BIT							
	X3	X2	X1	X0	3	2	1	0
GET_CONFIG_PAGE 0	N3	N2	N1	N0	D3	D2	D1	D0
GET_CONFIG_PAGE 1	N3	N2	N1	N0	D3	D2	D1	D0
GET_CONFIG_PAGE 2	0 (RFU)	0 (RFU)	AMPCOMP	ANTFAIL	D3	D2	D1	D0
GET_CONFIG_PAGE 3	0 (RFU)	0 (RFU)	AMPCOMP	ANTFAIL	D3	D2	D1	D0

Table 5 Description of the configuration page bits

BIT NAME	VALUE	DESCRIPTION
D3 to D0	XXXX	contents of the selected configuration page
N3 to N0	XXXX	current setting of the transmit pulse width
ANTFAIL	0 1	antenna failure no antenna failure antenna failure
AMPCOMP	0 1	amplitude comparison result (see also bit ACQAMP in Table 3) actual data signal amplitude is lower than the stored reference actual data signal amplitude is higher than the stored reference

HITAG reader chip

HTRC11001T

9 LIMITING VALUES

In accordance with the Absolute Maximum Rating System (IEC 60134); note 1.

SYMBOL	PARAMETER	MIN.	MAX.	UNIT
V_n	voltage at any pin (except pin RX)	-0.3	+6.5	V
$V_{n(max)}$	maximum voltage at any pin with respect to V_{DD} (except pin RX)	-0.3	$V_{DD} + 0.3$	V
V_{RX}	voltage at pin RX	-10	+12	V
$T_{j(max)}$	maximum junction temperature	-	140	°C
T_{stg}	storage temperature	-65	+125	°C

Note

1. Stress above one or more of the limiting values may cause permanent damage to the device. These are stresses ratings only and operation of the device at these or at any other conditions above those given in Chapter 10 not implied. Exposure or limiting values for extended periods may affect device reliability.

10 DC CHARACTERISTICS

All voltages are measured with respect to ground (pin V_{SS}); $T_{amb} = -40$ to $+85$ °C

SYMBOL	PARAMETER	CONDITIONS	MIN.	TYP.	MAX.	UNIT
Supply						
V_{DD}	supply voltage		4.5	5.0	5.5	V
I_{DD}	supply current	$V_{DD} = 5.5$ V; $I_{TX1} = I_{TX2} = 0$	-	4	10	mA
I_{idle}	idle current	$V_{DD} = 5.5$ V; note 1	-	0.2	0.4	mA
I_{pd}	power-down current	$V_{DD} = 5.5$ V	-	7	20	μA
Driver outputs (pins TX1 and TX2)						
$I_{ant(p)}$	antenna driver output current (peak value)	permanent	-	-	200	mA
		pulse load; $t_{on} < 400$ ms; ratio on : off = 1 : 4	-	-	400	mA
R_o	output resistance	both drivers together	-	2.5	7	Ω
Demodulator input (pin RX)						
V_i	input voltage	with respect to pin QGND	-8	-	+8	V
V_{diag}	diagnosis level voltage	with respect to pin QGND; $V_{DD} = 5$ V	-1.5	-1.15	-0.8	V
V_{QGND}	potential on pin QGND		$0.35V_{DD}$	$0.42V_{DD}$	$0.50V_{DD}$	V
R_i	internal demodulator impedance		17	25	33	kΩ
Digital inputs						
V_{IH}	HIGH-level input voltage		$0.7V_{DD}$	-	$V_{DD} + 0.3$ V	V
V_{IL}	LOW-level input voltage		-0.3	-	$0.3V_{DD}$	V
Digital outputs						
V_{OL}	LOW-level output voltage	$I_{OL(max)} = 1$ mA	-	-	0.4	V
I_{OL}	LOW-level output current	$V_{OL} \leq 0.4$ V	1	-	-	mA

Note

1. Power consumption of external quartz or any other component is not included.

HITAG reader chip

HTRC11001T

11 AC CHARACTERISTICS

$T_{amb} = -40$ to $+85$ °C.

SYMBOL	PARAMETER	CONDITIONS	MIN.	TYP.	MAX.	UNIT
Oscillator inputs (pins XTAL1 and XTAL2)						
f_{osc}	oscillator frequency	depending on bits FSEL1 and FSEL0	4	–	16	MHz
t_{st}	start-up time		–	4	10	ms
C_i	input capacitance on pin XTAL1		–	5	–	pF
R_i	input resistance	between pins XTAL1 and XTAL2	0.9	1.3	3.0	M Ω
External clock input (pin XTAL1)						
f_{ext}	external clock frequency	depending on bits FSEL1 and FSEL0	4	–	16	MHz
δ	duty cycle		40	–	60	%
Serial interface						
t_{su}	set-up time	pin MODE at V_{SS}	50	–	–	ns
t_h	hold time	pin MODE at V_{SS}	50	–	–	ns
Receiver (pin RX)						
$V_{RX(p-p)}$	sensitivity (peak-to-peak value)	receiver input	2	1	–	mV
t_d	receiver delay	bit FILTERL = 0	290	310	340	μ s
		bit FILTERL = 1	160	175	190	μ s
Demodulator valid time						
t_{rec}	demodulator recovery time	after clock stable; note 1	–	–	5	ms
		after WRITE-pulse; note 1	–	–	500	μ s
		after AST-step	–	0.7	1.5	ms
φ	phase measurement error		–	–	± 5.7	deg

Note

1. These short times require special command sequences. Please refer to the application note "AN 98080 Read/Write devices based on the HITAG Read/Write IC HTRC110".

HITAG reader chip

HTRC11001T

12 APPLICATION INFORMATION

Figure 4 shows a minimal application circuitry for the HTRC11001T.

The reader coil L_a together with the capacitor C_a forms a series resonant LC circuit ($f_0 = 125\text{ kHz}$). The high voltages in the LC circuit are divided to safe operating levels by R_v and the internal resistor R_i behind pin RX.

The two capacitors connected to pin XTAL1 and pin XTAL2 shall be the recommended values and types from the data sheet of the crystal.

Alternatively to a crystal, a ceramic resonator can be used or an external clock source can be connected to pin XTAL1.

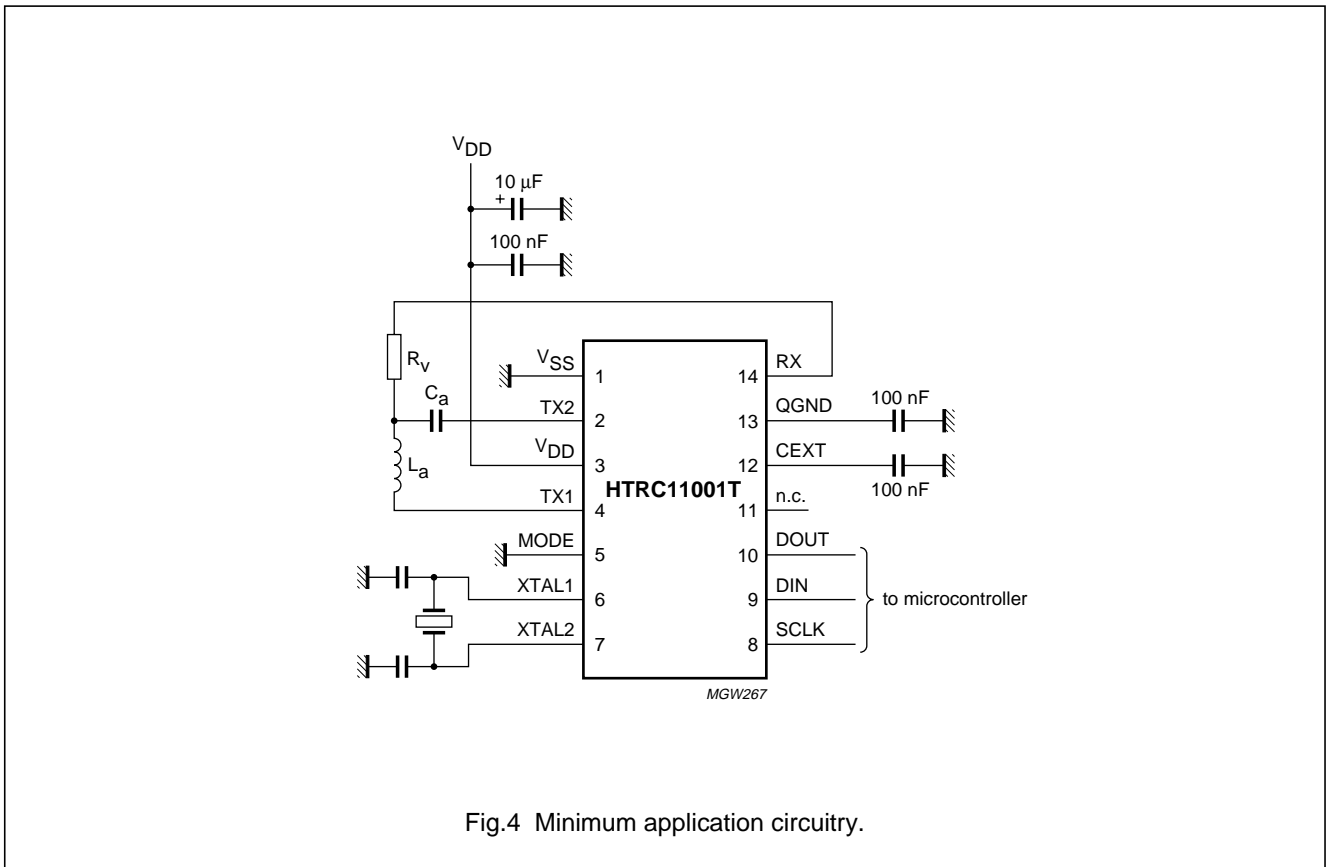

Fig.4 Minimum application circuitry.

HITAG reader chip

HTRC11001T

13 PACKAGE OUTLINE

SO14: plastic small outline package; 14 leads; body width 3.9 mm

SOT108-1

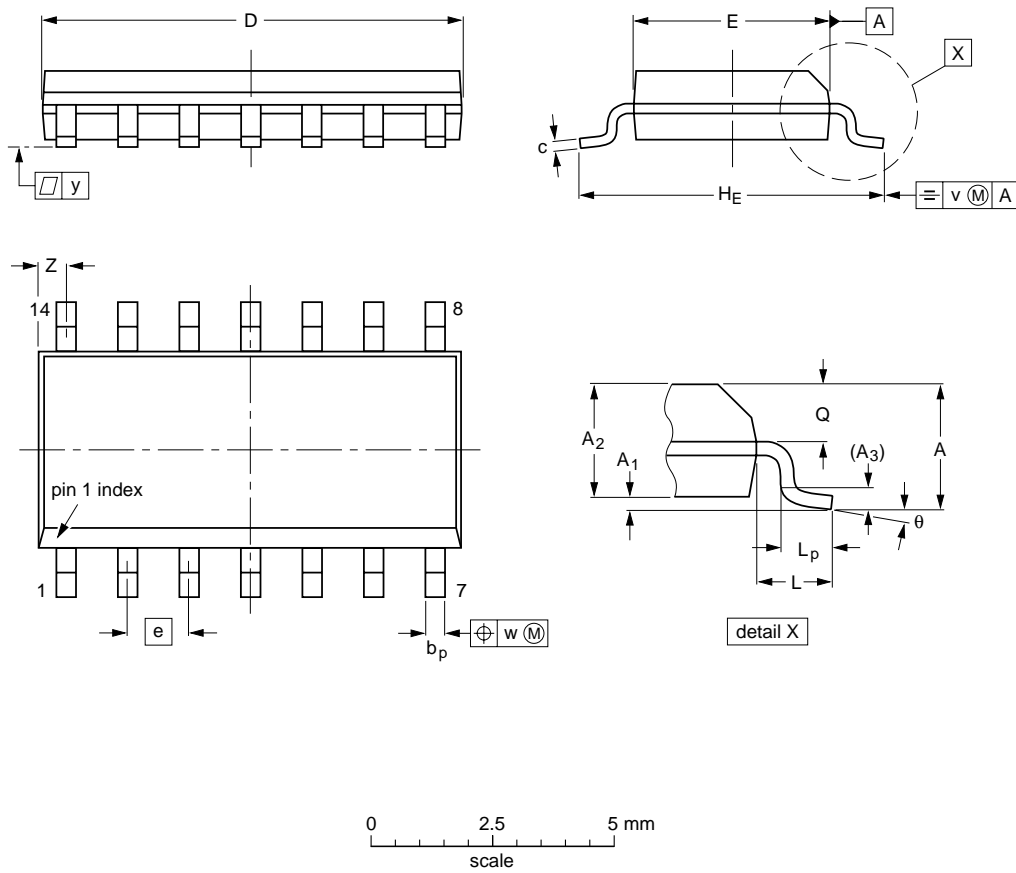

DIMENSIONS (inch dimensions are derived from the original mm dimensions)

UNIT	A max.	A ₁	A ₂	A ₃	b _p	c	D ⁽¹⁾	E ⁽¹⁾	e	H _E	L	L _p	Q	v	w	y	Z ⁽¹⁾	θ
mm	1.75	0.25 0.10	1.45 1.25	0.25	0.49 0.36	0.25 0.19	8.75 8.55	4.0 3.8	1.27	6.2 5.8	1.05	1.0 0.4	0.7 0.6	0.25	0.25	0.1	0.7 0.3	8° 0°
inches	0.069	0.010 0.004	0.057 0.049	0.01	0.019 0.014	0.0100 0.0075	0.35 0.34	0.16 0.15	0.050	0.244 0.228	0.041	0.039 0.016	0.028 0.024	0.01	0.01	0.004	0.028 0.012	

Note

1. Plastic or metal protrusions of 0.15 mm maximum per side are not included.

OUTLINE VERSION	REFERENCES				EUROPEAN PROJECTION	ISSUE DATE
	IEC	JEDEC	EIAJ			
SOT108-1	076E06	MS-012				97-05-22 99-12-27

HITAG reader chip

HTRC11001T

14 SOLDERING

14.1 Introduction to soldering surface mount packages

This text gives a very brief insight to a complex technology. A more in-depth account of soldering ICs can be found in our *"Data Handbook IC26; Integrated Circuit Packages"* (document order number 9398 652 90011).

There is no soldering method that is ideal for all surface mount IC packages. Wave soldering can still be used for certain surface mount ICs, but it is not suitable for fine pitch SMDs. In these situations reflow soldering is recommended.

14.2 Reflow soldering

Reflow soldering requires solder paste (a suspension of fine solder particles, flux and binding agent) to be applied to the printed-circuit board by screen printing, stencilling or pressure-syringe dispensing before package placement.

Several methods exist for reflowing; for example, convection or convection/infrared heating in a conveyor type oven. Throughput times (preheating, soldering and cooling) vary between 100 and 200 seconds depending on heating method.

Typical reflow peak temperatures range from 215 to 250 °C. The top-surface temperature of the packages should preferably be kept below 220 °C for thick/large packages, and below 235 °C for small/thin packages.

14.3 Wave soldering

Conventional single wave soldering is not recommended for surface mount devices (SMDs) or printed-circuit boards with a high component density, as solder bridging and non-wetting can present major problems.

To overcome these problems the double-wave soldering method was specifically developed.

If wave soldering is used the following conditions must be observed for optimal results:

- Use a double-wave soldering method comprising a turbulent wave with high upward pressure followed by a smooth laminar wave.
- For packages with leads on two sides and a pitch (e):
 - larger than or equal to 1.27 mm, the footprint longitudinal axis is **preferred** to be parallel to the transport direction of the printed-circuit board;
 - smaller than 1.27 mm, the footprint longitudinal axis **must** be parallel to the transport direction of the printed-circuit board.

The footprint must incorporate solder thieves at the downstream end.

- For packages with leads on four sides, the footprint must be placed at a 45° angle to the transport direction of the printed-circuit board. The footprint must incorporate solder thieves downstream and at the side corners.

During placement and before soldering, the package must be fixed with a droplet of adhesive. The adhesive can be applied by screen printing, pin transfer or syringe dispensing. The package can be soldered after the adhesive is cured.

Typical dwell time is 4 seconds at 250 °C.

A mildly-activated flux will eliminate the need for removal of corrosive residues in most applications.

14.4 Manual soldering

Fix the component by first soldering two diagonally-opposite end leads. Use a low voltage (24 V or less) soldering iron applied to the flat part of the lead. Contact time must be limited to 10 seconds at up to 300 °C.

When using a dedicated tool, all other leads can be soldered in one operation within 2 to 5 seconds between 270 and 320 °C.

HITAG reader chip

HTRC11001T

14.5 Suitability of surface mount IC packages for wave and reflow soldering methods

PACKAGE	SOLDERING METHOD	
	WAVE	REFLOW ⁽¹⁾
BGA, HBGA, LFBGA, SQFP, TFBGA	not suitable	suitable
HBCC, HLQFP, HSQFP, HSOP, HTQFP, HTSSOP, HVQFN, SMS	not suitable ⁽²⁾	suitable
PLCC ⁽³⁾ , SO, SOJ	suitable	suitable
LQFP, QFP, TQFP	not recommended ⁽³⁾⁽⁴⁾	suitable
SSOP, TSSOP, VSO	not recommended ⁽⁵⁾	suitable

Notes

1. All surface mount (SMD) packages are moisture sensitive. Depending upon the moisture content, the maximum temperature (with respect to time) and body size of the package, there is a risk that internal or external package cracks may occur due to vaporization of the moisture in them (the so called popcorn effect). For details, refer to the Drypack information in the *“Data Handbook IC26; Integrated Circuit Packages; Section: Packing Methods”*.
2. These packages are not suitable for wave soldering as a solder joint between the printed-circuit board and heatsink (at bottom version) can not be achieved, and as solder may stick to the heatsink (on top version).
3. If wave soldering is considered, then the package must be placed at a 45° angle to the solder wave direction. The package footprint must incorporate solder thieves downstream and at the side corners.
4. Wave soldering is only suitable for LQFP, TQFP and QFP packages with a pitch (e) equal to or larger than 0.8 mm; it is definitely not suitable for packages with a pitch (e) equal to or smaller than 0.65 mm.
5. Wave soldering is only suitable for SSOP and TSSOP packages with a pitch (e) equal to or larger than 0.65 mm; it is definitely not suitable for packages with a pitch (e) equal to or smaller than 0.5 mm.

HITAG reader chip

HTRC11001T

15 DATA SHEET STATUS

DATA SHEET STATUS ⁽¹⁾	PRODUCT STATUS ⁽²⁾	DEFINITIONS
Objective data	Development	This data sheet contains data from the objective specification for product development. Philips Semiconductors reserves the right to change the specification in any manner without notice.
Preliminary data	Qualification	This data sheet contains data from the preliminary specification. Supplementary data will be published at a later date. Philips Semiconductors reserves the right to change the specification without notice, in order to improve the design and supply the best possible product.
Product data	Production	This data sheet contains data from the product specification. Philips Semiconductors reserves the right to make changes at any time in order to improve the design, manufacturing and supply. Changes will be communicated according to the Customer Product/Process Change Notification (CPCN) procedure SNW-SQ-650A.

Notes

1. Please consult the most recently issued data sheet before initiating or completing a design.
2. The product status of the device(s) described in this data sheet may have changed since this data sheet was published. The latest information is available on the Internet at URL <http://www.semiconductors.philips.com>.

16 DEFINITIONS

Short-form specification — The data in a short-form specification is extracted from a full data sheet with the same type number and title. For detailed information see the relevant data sheet or data handbook.

Limiting values definition — Limiting values given are in accordance with the Absolute Maximum Rating System (IEC 60134). Stress above one or more of the limiting values may cause permanent damage to the device. These are stress ratings only and operation of the device at these or at any other conditions above those given in the Characteristics sections of the specification is not implied. Exposure to limiting values for extended periods may affect device reliability.

Application information — Applications that are described herein for any of these products are for illustrative purposes only. Philips Semiconductors make no representation or warranty that such applications will be suitable for the specified use without further testing or modification.

17 DISCLAIMERS

Life support applications — These products are not designed for use in life support appliances, devices, or systems where malfunction of these products can reasonably be expected to result in personal injury. Philips Semiconductors customers using or selling these products for use in such applications do so at their own risk and agree to fully indemnify Philips Semiconductors for any damages resulting from such application.

Right to make changes — Philips Semiconductors reserves the right to make changes, without notice, in the products, including circuits, standard cells, and/or software, described or contained herein in order to improve design and/or performance. Philips Semiconductors assumes no responsibility or liability for the use of any of these products, conveys no licence or title under any patent, copyright, or mask work right to these products, and makes no representations or warranties that these products are free from patent, copyright, or mask work right infringement, unless otherwise specified.

Philips Semiconductors – a worldwide company

Contact information

For additional information please visit <http://www.semiconductors.philips.com>. Fax: +31 40 27 24825

For sales offices addresses send e-mail to: sales.addresses@www.semiconductors.philips.com.

© Koninklijke Philips Electronics N.V. 2001

SCA73

All rights are reserved. Reproduction in whole or in part is prohibited without the prior written consent of the copyright owner.

The information presented in this document does not form part of any quotation or contract, is believed to be accurate and reliable and may be changed without notice. No liability will be accepted by the publisher for any consequence of its use. Publication thereof does not convey nor imply any license under patent- or other industrial or intellectual property rights.

Printed in The Netherlands

613502/02/pp20

Date of release: 2001 Nov 23

Document order number: 9397 750 08329

Let's make things better.

**Philips
Semiconductors**



PHILIPS



LittleDiode supplies new, hard to find or obsolete electronic components and semiconductors all over the world.

With over two million different components listed you are sure to find the part you need.

Feel free to visit us today at our online store:

LittleDiode.com

Looking forward to providing you with the best possible service.