

2.6A, 55V, 0.090 Ohm, N-Channel UltraFET Power MOSFET



This N-Channel power MOSFET is manufactured using the innovative UltraFET® process. This advanced process technology achieves the

lowest possible on-resistance per silicon area, resulting in outstanding performance. This device is capable of withstanding high energy in the avalanche mode and the diode exhibits very low reverse recovery time and stored charge. It was designed for use in applications where power efficiency is important, such as switching regulators, switching converters, motor drivers, relay drivers, low-voltage bus switches, and power management in portable and battery-operated products.

Formerly developmental type TA75307.

Ordering Information

PART NUMBER	PACKAGE	BRAND
HUF75307T3ST	SOT-223	5307

NOTE: HUF75307T3ST is available only in tape and reel.

Features

- 2.6A, 55V
- Ultra Low On-Resistance, $r_{DS(ON)} = 0.090\Omega$
- Diode Exhibits Both High Speed and Soft Recovery
- Temperature Compensating PSPICE® Model
- Thermal Impedance SPICE Model
- Peak Current vs Pulse Width Curve
- UIS Rating Curve
- Related Literature
 - TB334, "Guidelines for Soldering Surface Mount Components to PC Boards"

Symbol

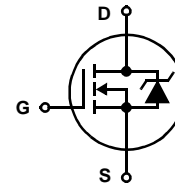

Packaging

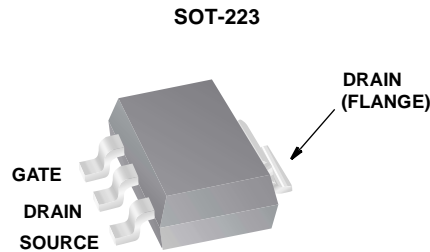

Product reliability information can be found at <http://www.fairchildsemi.com/products/discrete/reliability/index.html>

For severe environments, see our Automotive HUFA series.

All Fairchild semiconductor products are manufactured, assembled and tested under ISO9000 and QS9000 quality systems certification.

HUF75307T3ST

Absolute Maximum Ratings $T_A = 25^\circ\text{C}$, Unless Otherwise Specified

			UNITS
Drain to Source Voltage (Note 1).....	V_{DSS}	55	V
Drain to Gate Voltage ($R_{GS} = 20k\Omega$) (Note 1).....	V_{DGR}	55	V
Gate to Source Voltage.....	V_{GS}	$\pm 20V$	V
Drain Current			
Continuous (Figure 2) (Note 2).....	I_D	2.6	A
Pulsed Drain Current.....	I_{DM}	Figure 5	
Pulsed Avalanche Rating.....	E_{AS}	Figures 6, 14, 15	
Power Dissipation (Note 2).....	P_D	1.1	W
Derate Above 25°C		9.09	$\text{mW}/^\circ\text{C}$
Operating and Storage Temperature.....	T_J, T_{STG}	-55 to 150	$^\circ\text{C}$
Maximum Temperature for Soldering			
Leads at 0.063in (1.6mm) from Case for 10s.....	T_L	300	$^\circ\text{C}$
Package Body for 10s, See Techbrief 334.....	T_{pkg}	260	$^\circ\text{C}$

CAUTION: Stresses above those listed in "Absolute Maximum Ratings" may cause permanent damage to the device. This is a stress only rating and operation of the device at these or any other conditions above those indicated in the operational sections of this specification is not implied.

NOTE:

- $T_J = 25^\circ\text{C}$ to 125°C .

Electrical Specifications $T_A = 25^\circ\text{C}$, Unless Otherwise Specified

PARAMETER	SYMBOL	TEST CONDITIONS	MIN	TYP	MAX	UNITS
Drain to Source Breakdown Voltage	BV_{DSS}	$I_D = 250\mu\text{A}, V_{GS} = 0V$ (Figure 11)	55	-	-	V
Gate to Source Threshold Voltage	$V_{GS(TH)}$	$V_{GS} = V_{DS}, I_D = 250\mu\text{A}$ (Figure 10)	2	-	4	V
Zero Gate Voltage Drain Current	I_{DSS}	$V_{DS} = 50V, V_{GS} = 0V$	-	-	1	μA
		$V_{DS} = 45V, V_{GS} = 0V, T_A = 150^\circ\text{C}$	-	-	250	μA
Gate to Source Leakage Current	I_{GSS}	$V_{GS} = \pm 20V$	-	-	100	nA
Drain to Source On Resistance	$r_{DS(ON)}$	$I_D = 2.6A, V_{GS} = 10V$ (Figure 9)	-	0.070	0.090	Ω
Turn-On Time	t_{ON}	$V_{DD} = 30V, I_D \cong 2.6A,$ $R_L = 11.5\Omega, V_{GS} = 10V,$ $R_{GS} = 25\Omega$	-	-	55	ns
Turn-On Delay Time	$t_{d(ON)}$		-	5	-	ns
Rise Time	t_r		-	30	-	ns
Turn-Off Delay Time	$t_{d(OFF)}$		-	35	-	ns
Fall Time	t_f		-	25	-	ns
Turn-Off Time	t_{OFF}		-	-	90	ns
Total Gate Charge	$Q_{g(TOT)}$		$V_{GS} = 0V$ to $20V$	-	14	17
Gate Charge at 10V	$Q_{g(10)}$	$V_{GS} = 0V$ to $10V$	-	8.3	10	nC
Threshold Gate Charge	$Q_{g(TH)}$	$V_{GS} = 0V$ to $2V$	-	0.6	0.8	nC
Gate to Source Gate Charge	Q_{gs}		-	1.00	-	nC
Gate to Drain "Miller" Charge	Q_{gd}		-	4.00	-	nC
Input Capacitance	C_{ISS}	$V_{DS} = 25V, V_{GS} = 0V,$ $f = 1\text{MHz}$ (Figure 12)	-	250	-	pF
Output Capacitance	C_{OSS}		-	115	-	pF
Reverse Transfer Capacitance	C_{RSS}		-	30	-	pF
Thermal Resistance Junction to Ambient	$R_{\theta JA}$	Pad Area = 0.171 in^2 (see note 2)	-	-	110	$^\circ\text{C}/\text{W}$
		Pad Area = 0.068 in^2	-	-	128	$^\circ\text{C}/\text{W}$
		Pad Area = 0.026 in^2	-	-	147	$^\circ\text{C}/\text{W}$

Source to Drain Diode Specifications

PARAMETER	SYMBOL	TEST CONDITIONS	MIN	TYP	MAX	UNITS
Source to Drain Diode Voltage	V_{SD}	$I_{SD} = 2.6A$	-	-	1.25	V
Reverse Recovery Time	t_{rr}	$I_{SD} = 2.6A, dI_{SD}/dt = 100A/\mu\text{s}$	-	-	40	ns
Reverse Recovered Charge	Q_{RR}	$I_{SD} = 2.6A, dI_{SD}/dt = 100A/\mu\text{s}$	-	-	50	nC

NOTE:

- $110^\circ\text{C}/\text{W}$ measured using FR-4 board with 0.171 in^2 footprint for 1000s.

Typical Performance Curves

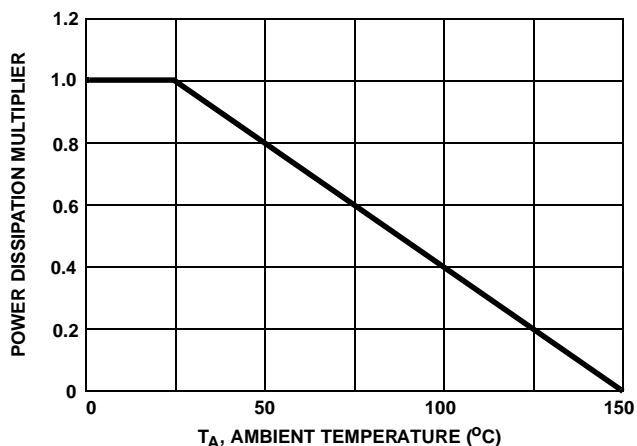

FIGURE 1. NORMALIZED POWER DISSIPATION vs AMBIENT TEMPERATURE

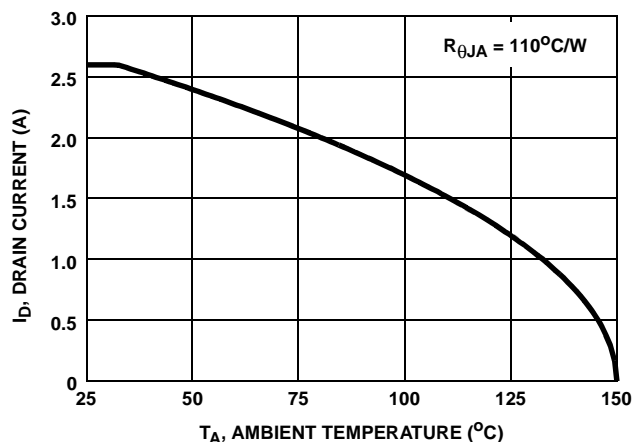

FIGURE 2. MAXIMUM CONTINUOUS DRAIN CURRENT vs AMBIENT TEMPERATURE

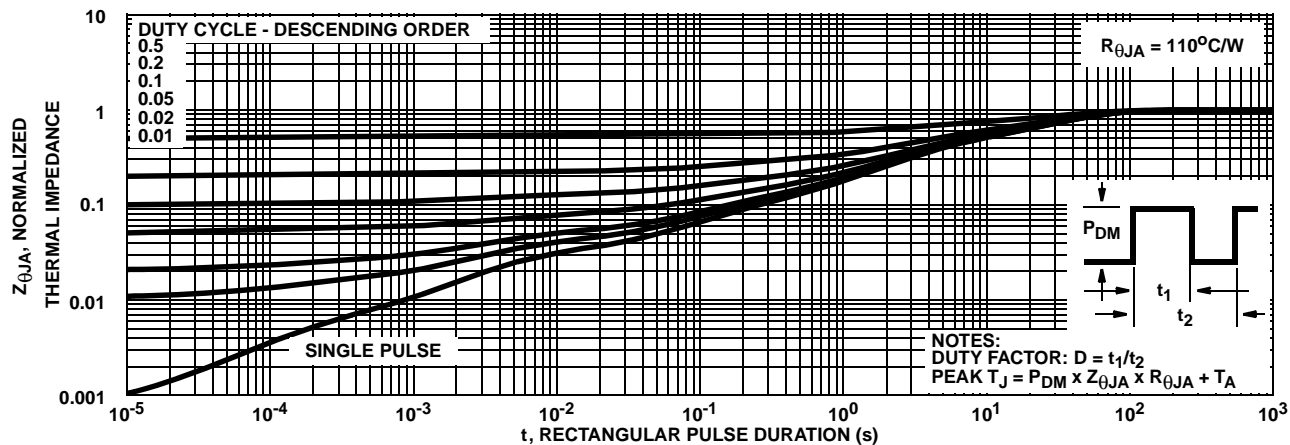

FIGURE 3. NORMALIZED MAXIMUM TRANSIENT THERMAL IMPEDANCE

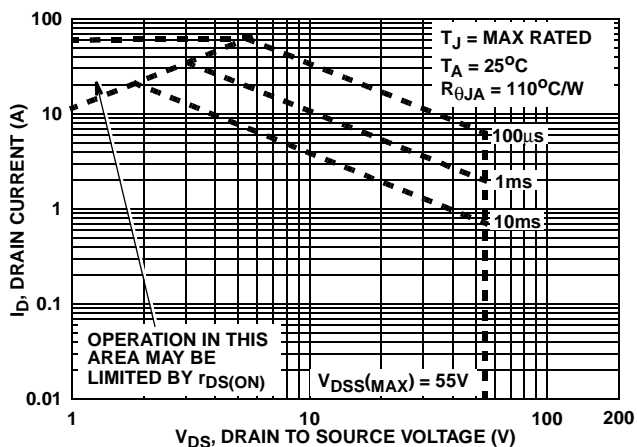

FIGURE 4. FORWARD BIAS SAFE OPERATING AREA

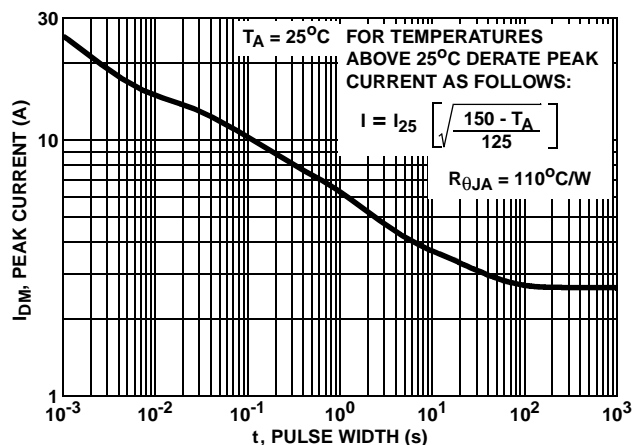
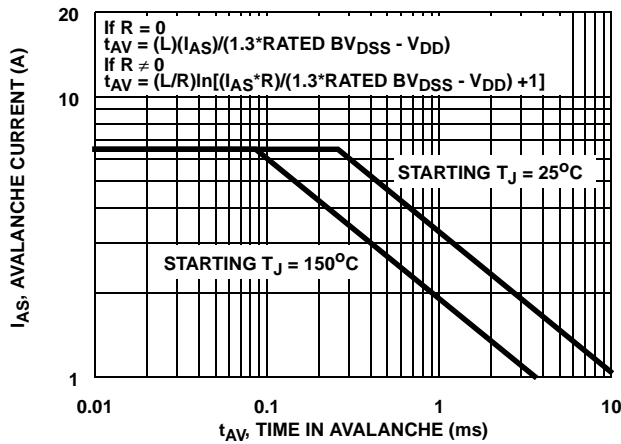

FIGURE 5. PEAK CURRENT CAPABILITY

Typical Performance Curves (Continued)



NOTE: Refer to Fairchild Application Notes AN9321 and AN9322.
FIGURE 6. UNCLAMPED INDUCTIVE SWITCHING CAPABILITY

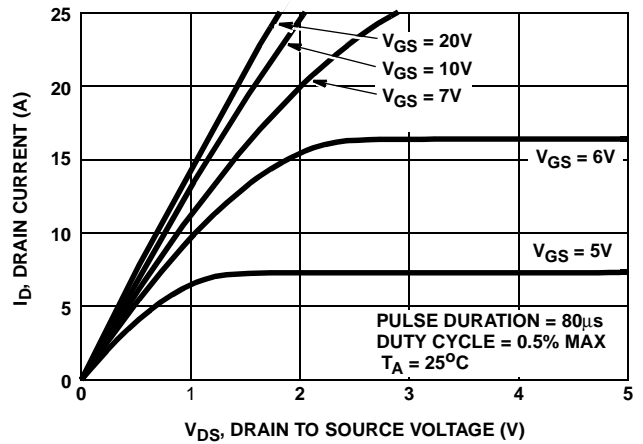

FIGURE 7. SATURATION CHARACTERISTICS

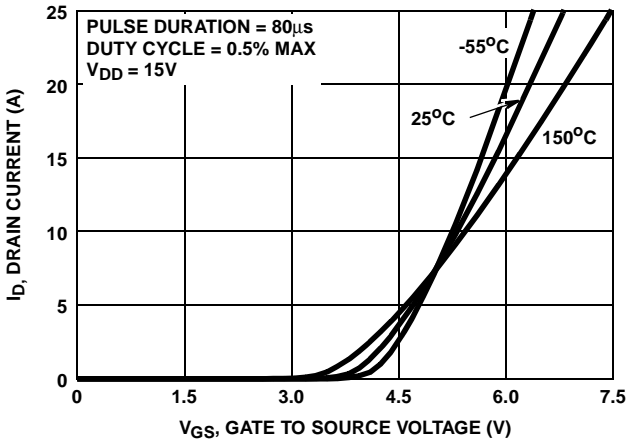

FIGURE 8. TRANSFER CHARACTERISTICS

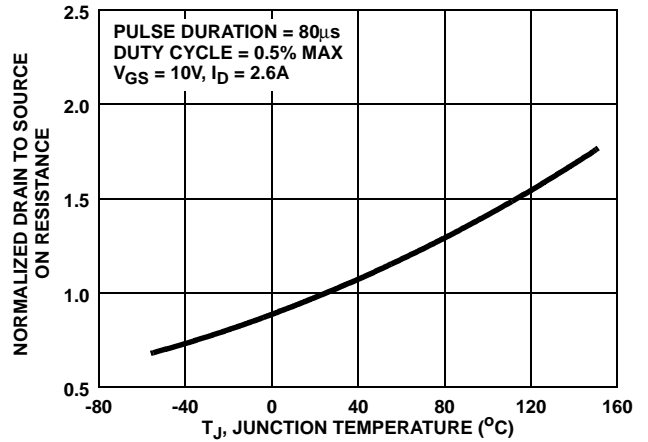

FIGURE 9. NORMALIZED DRAIN TO SOURCE ON RESISTANCE vs JUNCTION TEMPERATURE

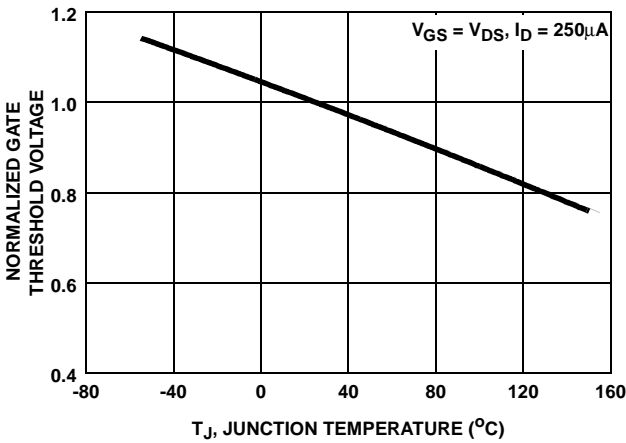

FIGURE 10. NORMALIZED GATE THRESHOLD VOLTAGE vs JUNCTION TEMPERATURE

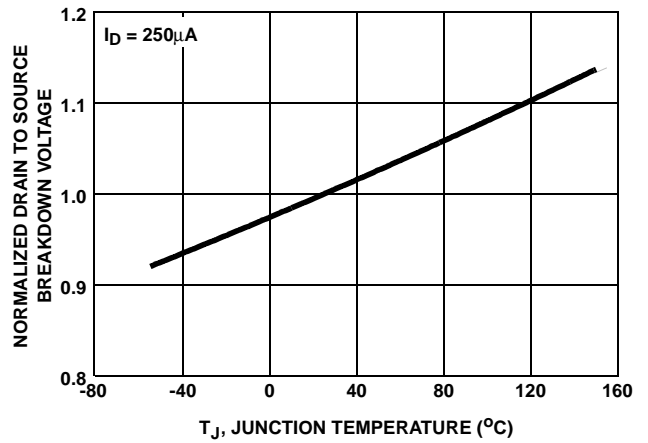

FIGURE 11. NORMALIZED DRAIN TO SOURCE BREAKDOWN VOLTAGE vs JUNCTION TEMPERATURE

Typical Performance Curves (Continued)

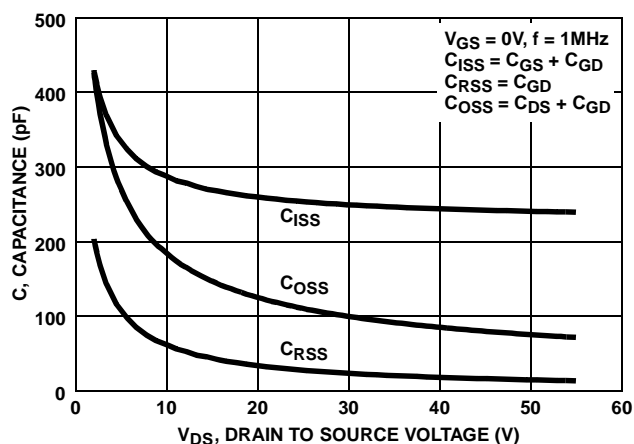
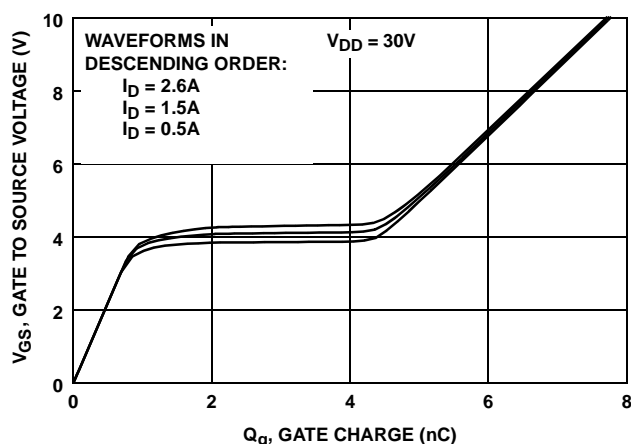

FIGURE 12. CAPACITANCE vs DRAIN TO SOURCE VOLTAGE



NOTE: Refer to Fairchild Application Notes AN7254 and AN7260.

FIGURE 13. GATE CHARGE WAVEFORMS FOR CONSTANT GATE CURRENT

Test Circuits and Waveforms

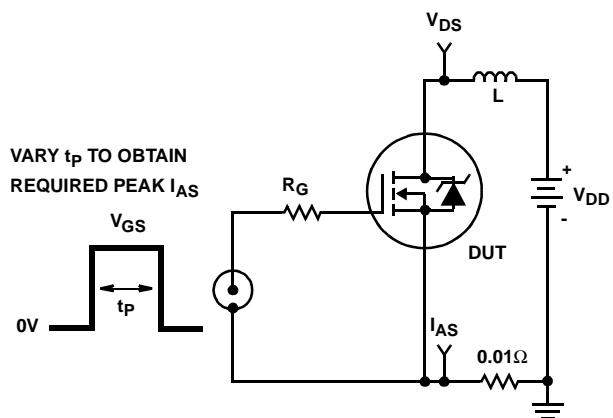

FIGURE 14. UNCLAMPED ENERGY TEST CIRCUIT

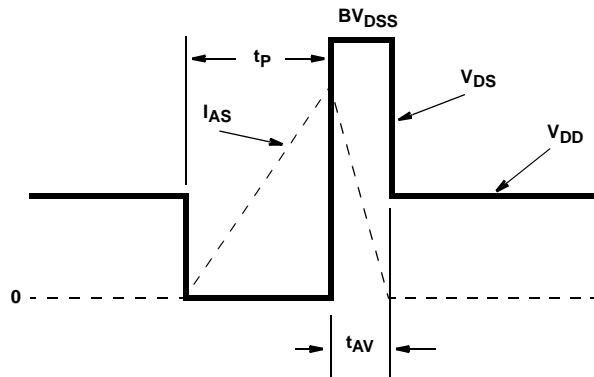

FIGURE 15. UNCLAMPED ENERGY WAVEFORMS

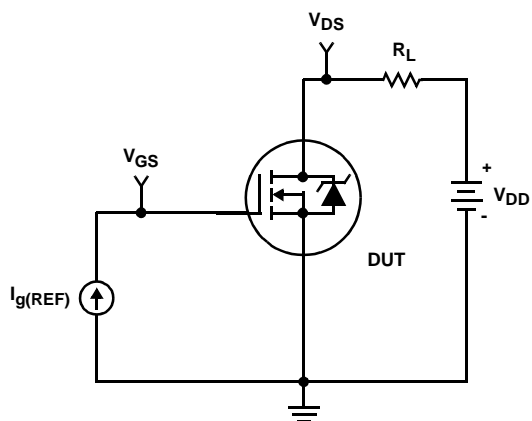

FIGURE 16. GATE CHARGE TEST CIRCUIT

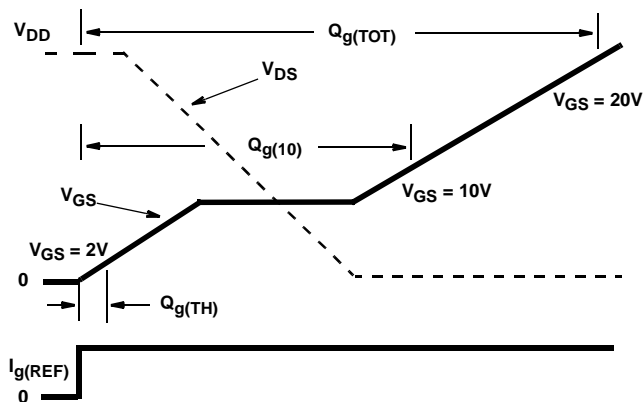

FIGURE 17. GATE CHARGE WAVEFORM

Test Circuits and Waveforms (Continued)

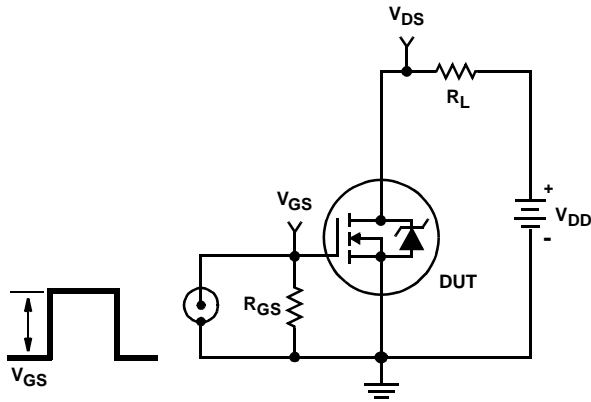

FIGURE 18. SWITCHING TIME TEST CIRCUIT

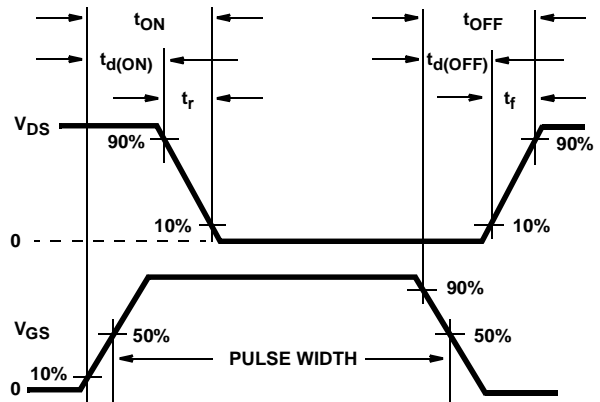

FIGURE 19. RESISTIVE SWITCHING WAVEFORMS

Thermal Resistance vs. Mounting Pad Area

The maximum rated junction temperature, $T_{J(MAX)}$, and the thermal resistance of the heat dissipating path determines the maximum allowable device power dissipation, $P_{D(MAX)}$, in an application. Therefore the application's ambient temperature, T_A ($^{\circ}C$), and thermal resistance $R_{\theta JA}$ ($^{\circ}C/W$) must be reviewed to ensure that $T_{J(MAX)}$ is never exceeded. Equation 1 mathematically represents the relationship and serves as the basis for establishing the rating of the part.

$$P_{D(MAX)} = \frac{(T_{J(MAX)} - T_A)}{R_{\theta JA}} \quad (EQ. 1)$$

In using surface mount devices such as the SOT-223 package, the environment in which it is applied will have a significant influence on the part's current and maximum power dissipation ratings. Precise determination of the $P_{D(MAX)}$ is complex and influenced by many factors:

1. Mounting pad area onto which the device is attached and whether there is copper on one side or both sides of the board.
2. The number of copper layers and the thickness of the board.
3. The use of external heat sinks.
4. The use of thermal vias.
5. Air flow and board orientation.
6. For non steady state applications, the pulse width, the duty cycle and the transient thermal response of the part, the board and the environment they are in.

Fairchild provides thermal information to assist the designer's preliminary application evaluation. Figure 20 defines the $R_{\theta JA}$ for the device as a function of the top copper (component side) area. This is for a horizontally positioned FR-4 board with 1oz copper after 1000 seconds

of steady state power with no air flow. This graph provides the necessary information for calculation of the steady state junction temperature or power dissipation. Pulse applications can be evaluated using the Fairchild device Spice thermal model or manually utilizing the normalized maximum transient thermal impedance curve.

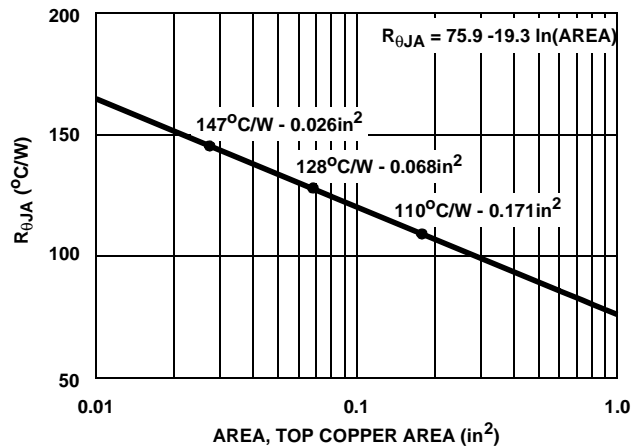

FIGURE 20. THERMAL RESISTANCE vs MOUNTING PAD AREA

Displayed on the curve are the three $R_{\theta JA}$ values listed in the Electrical Specifications table. The three points were chosen to depict the compromise between the copper board area, the thermal resistance and ultimately the power dissipation, $P_{D(MAX)}$. Thermal resistances corresponding to other component side copper areas can be obtained from Figure 20 or by calculation using Equation 2. The area, in square inches is the top copper area including the gate and source pads.

$$R_{\theta JA} = 75.9 - 19.3 \times \ln(\text{Area}) \quad (EQ. 2)$$

HUF75307T3ST

PSPICE Electrical Model

.SUBCKT HUF75307T3ST 2 1 3 ; rev 7/25/97

CA 12 8 3.5e-10
 CB 15 14 3.7e-10
 CIN 6 8 2.26e-10

DBODY 7 5 DBODYMOD
 DBREAK 5 11 DBREAKMOD
 DPLCAP 10 5 DPLCAPMOD

EBREAK 11 7 17 18 57.4
 EDS 14 8 5 8 1
 EGS 13 8 6 8 1
 ESG 6 10 6 8 1
 EVTHRES 6 21 19 8 1
 EVTEMP 20 6 18 22 1

IT 8 17 1

LDRAIN 2 5 1e-9
 LGATE 1 9 1.4e-9
 LSOURCE 3 7 3.1e-10
 K1 LGATE LSOURCE 0.131

MMED 16 6 8 8 MMEDMOD
 MSTRO 16 6 8 8 MSTROMOD
 MWEAK 16 21 8 8 MWEAKMOD

RBREAK 17 18 RBREAKMOD 1
 RDRAIN 50 16 RDRAINMOD 7.0e-3
 RGATE 9 20 1.9
 RLDRAIN 2 5 10
 RLGATE 1 9 14
 RLSOURCE 3 7 3
 RSLC1 5 51 RSLCMOD 1e-6
 RSLC2 5 50 1e3
 RSOURCE 8 7 RSOURCEMOD 5.6e-2
 RVTHRES 22 8 RVTHRESMOD 1
 RVTEMP 18 19 RVTEMPMOD 1

S1A 6 12 13 8 S1AMOD
 S1B 13 12 13 8 S1BMOD
 S2A 6 15 14 13 S2AMOD
 S2B 13 15 14 13 S2BMOD

VBAT 22 19 DC 1

ESLC 51 50 VALUE={(V(5,51)/ABS(V(5,51)))*(PWR(V(5,51))/(1e-6*50),3)}

.MODEL DBODYMOD D (IS = 2.6e-13 RS = 2.34e-2 IKF = 5.5 N = 0.995 TRS1 = 2.8e-3 TRS2 = 1.1e-5 CJO = 3.7e-10 TT = 3.5e-8 M = 0.46 + XTI = 5.5)

.MODEL DBREAKMOD D (RS = 0. 5IKF = 0.1 N = 1 TRS1 = 3e-3 TRS2 = -5e-5)

.MODEL DPLCAPMOD D (CJO = 5.6e-1 0IS = 1e-3 0N = 10 M = 0.92)

.MODEL MMEDMOD NMOS (VTO = 3.25 KP = 1.8 IS = 1e-30 N = 10 TOX = 1 L = 1u W = 1u RG = 1.9)

.MODEL MSTROMOD NMOS (VTO = 3.68 KP = 13.5 IS = 1e-30 N = 10 TOX = 1 L = 1u W = 1u)

.MODEL MWEAKMOD NMOS (VTO = 2.83 KP = 0.03 IS = 1e-30 N = 10 TOX = 1 L = 1u W = 1u RG = 19 RS = 0.1)

.MODEL RBREAKMOD RES (TC1 = 1.08e-3 TC2 = 5e-7)

.MODEL RDRAINMOD RES (TC1 = 1.7e-2 TC2 = 1e-4)

.MODEL RSLCMOD RES (TC1 = 1e-9 TC2 = 1e-4)

.MODEL RSOURCEMOD RES (TC1 = 3.3e-3 TC2 = 1e-9)

.MODEL RVTHRESMOD RES (TC1 = -1.9e-3 TC2 = -4e-6)

.MODEL RVTEMPMOD RES (TC1 = -2.9e-3 TC2 = 2.2e-6)

.MODEL S1AMOD VSWITCH (RON = 1e-5 ROFF = 0.1 VON = -7.1 VOFF = -4)

.MODEL S1BMOD VSWITCH (RON = 1e-5 ROFF = 0.1 VON = -4 VOFF = -7.1)

.MODEL S2AMOD VSWITCH (RON = 1e-5 ROFF = 0.1 VON = 0.01 VOFF = 1.9)

.MODEL S2BMOD VSWITCH (RON = 1e-5 ROFF = 0.1 VON = 1.9 VOFF = 0.01)

.ENDS

NOTE: For further discussion of the PSPICE model, consult **A New PSPICE Sub-Circuit for the Power MOSFET Featuring Global Temperature Options**; IEEE Power Electronics Specialist Conference Records, 1991, written by William J. Hepp and C. Frank Wheatley.

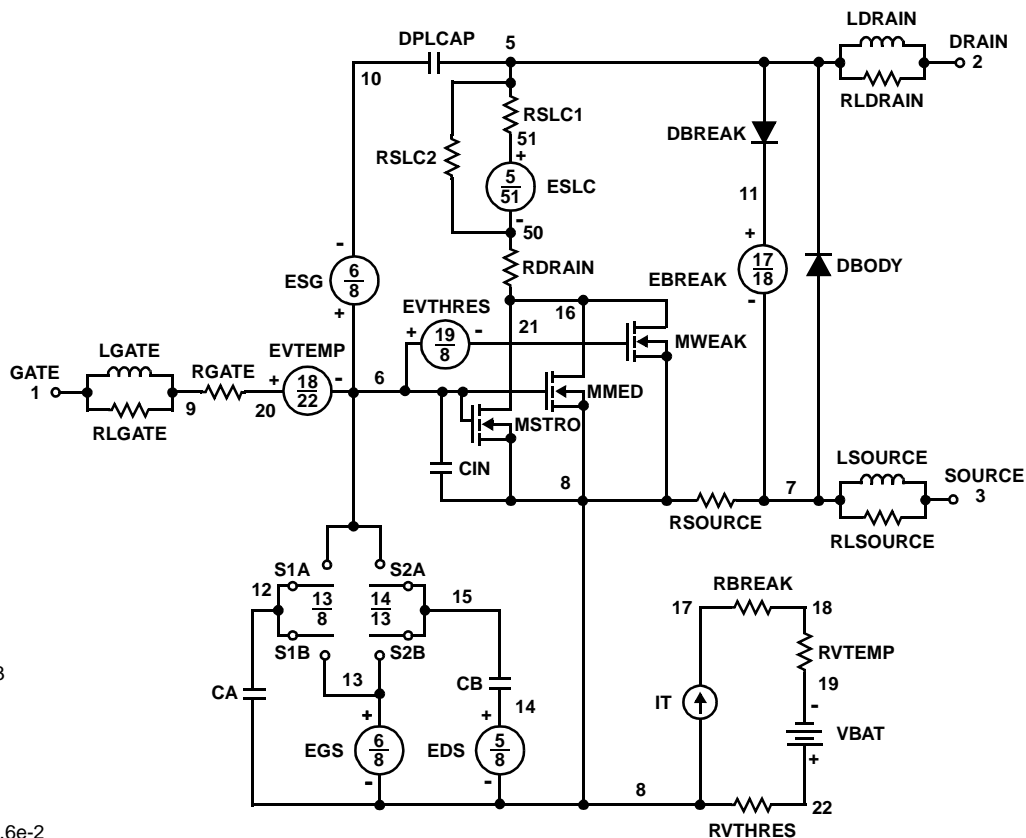

HUF75307T3ST

SPICE Thermal Model

REV 15 Nov 97

HUF75307T3ST

CTHERM1 7 6 7.5e-5
CTHERM2 6 5 3.5e-4
CTHERM3 5 4 1.2e-3
CTHERM4 4 3 1.5e-2
CTHERM5 3 2 6.9e-2
CTHERM6 2 1 4.5e-1

RTHERM1 7 6 7.5e-2
RTHERM2 6 5 2.0e-1
RTHERM3 5 4 1.2
RTHERM4 4 3 3.3
RTHERM5 3 2 28
RTHERM6 2 1 90

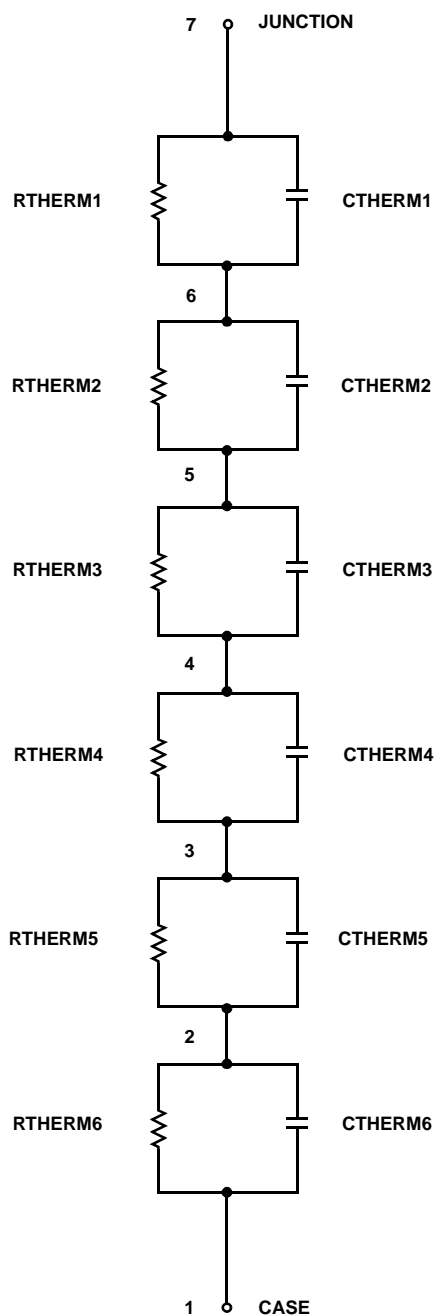

TRADEMARKS

The following are registered and unregistered trademarks Fairchild Semiconductor owns or is authorized to use and is not intended to be an exhaustive list of all such trademarks.

ACE _x TM	FAST [®]	OPTOLOGIC TM	SMART START TM	VCX TM
Bottomless TM	FAST _r TM	OPTOPLANAR TM	STAR*POWER TM	
CoolFET TM	FRFET TM	PACMAN TM	Stealth TM	
CROSSVOLT TM	GlobalOptoisolator TM	POP TM	SuperSOT TM -3	
DenseTrench TM	GTO TM	Power247 TM	SuperSOT TM -6	
DOMET TM	HiSeC TM	PowerTrench [®]	SuperSOT TM -8	
EcoSPARK TM	ISOPLANAR TM	QFET TM	SyncFET TM	
E ² CMOS TM	LittleFET TM	QST TM	TinyLogic TM	
EnSigna TM	MicroFET TM	QT Optoelectronics TM	TruTranslation TM	
FACT TM	MicroPak TM	Quiet Series TM	UHC TM	
FACT Quiet Series TM	MICROWIRE TM	SILENT SWITCHER [®]	UltraFET [®]	

STAR*POWER is used under license

DISCLAIMER

FAIRCHILD SEMICONDUCTOR RESERVES THE RIGHT TO MAKE CHANGES WITHOUT FURTHER NOTICE TO ANY PRODUCTS HEREIN TO IMPROVE RELIABILITY, FUNCTION OR DESIGN. FAIRCHILD DOES NOT ASSUME ANY LIABILITY ARISING OUT OF THE APPLICATION OR USE OF ANY PRODUCT OR CIRCUIT DESCRIBED HEREIN; NEITHER DOES IT CONVEY ANY LICENSE UNDER ITS PATENT RIGHTS, NOR THE RIGHTS OF OTHERS.

LIFE SUPPORT POLICY

FAIRCHILD'S PRODUCTS ARE NOT AUTHORIZED FOR USE AS CRITICAL COMPONENTS IN LIFE SUPPORT DEVICES OR SYSTEMS WITHOUT THE EXPRESS WRITTEN APPROVAL OF FAIRCHILD SEMICONDUCTOR CORPORATION.

As used herein:

1. Life support devices or systems are devices or systems which, (a) are intended for surgical implant into the body, or (b) support or sustain life, or (c) whose failure to perform when properly used in accordance with instructions for use provided in the labeling, can be reasonably expected to result in significant injury to the user.
2. A critical component is any component of a life support device or system whose failure to perform can be reasonably expected to cause the failure of the life support device or system, or to affect its safety or effectiveness.

PRODUCT STATUS DEFINITIONS

Definition of Terms

Datasheet Identification	Product Status	Definition
Advance Information	Formative or In Design	This datasheet contains the design specifications for product development. Specifications may change in any manner without notice.
Preliminary	First Production	This datasheet contains preliminary data, and supplementary data will be published at a later date. Fairchild Semiconductor reserves the right to make changes at any time without notice in order to improve design.
No Identification Needed	Full Production	This datasheet contains final specifications. Fairchild Semiconductor reserves the right to make changes at any time without notice in order to improve design.
Obsolete	Not In Production	This datasheet contains specifications on a product that has been discontinued by Fairchild semiconductor. The datasheet is printed for reference information only.



LittleDiode supplies new, hard to find or obsolete electronic components and semiconductors all over the world.

With over two million different components listed you are sure to find the part you need.

Feel free to visit us today at our online store:

LittleDiode.com

Looking forward to providing you with the best possible service.