



Integrated Device Technology, Inc.

### 3.3V CMOS 16-BIT TRANSPARENT LATCH

IDT74FCT163373/A/C

#### FEATURES:

- 0.5 MICRON CMOS Technology
- **Typical tsk(o) (Output Skew) < 250ps**
- ESD > 2000V per MIL-STD-883, Method 3015; > 200V using machine model (C = 200pF, R = 0)
- Packages include 25 mil pitch SSOP, 19.6 mil pitch TSSOP and 15.7 mil pitch TVSOP
- Extended commercial range of -40°C to +85°C
- VCC = 3.3V ±0.3V, Normal Range or VCC = 2.7 to 3.6V, Extended Range
- CMOS power levels (0.4µW typ. static)
- Rail-to-Rail output swing for increased noise margin
- Low Ground Bounce (0.3V typ.)
- Inputs (except I/O) can be driven by 3.3V or 5V components

#### DESCRIPTION:

The FCT163373/A/C 16-bit transparent D-type latches are built using advanced dual metal CMOS technology. These high-speed, low-power latches are ideal for temporary storage of data. They can be used for implementing memory address latches, I/O ports, and bus drivers. The Output Enable and Latch Enable controls are organized to operate each device as two 8-bit latches or one 16-bit latch. Flow-through organization of signal pins simplifies layout. All inputs are designed with hysteresis for improved noise margin.

The inputs of FCT163373/A/C can be driven from either 3.3V or 5V devices. This feature allows the use of these transparent latches as translators in a mixed 3.3V/5V supply system. With xLE inputs HIGH, the FCT163373/A/C can be used as buffers to connect 5V components to a 3.3V bus.

#### FUNCTIONAL BLOCK DIAGRAM

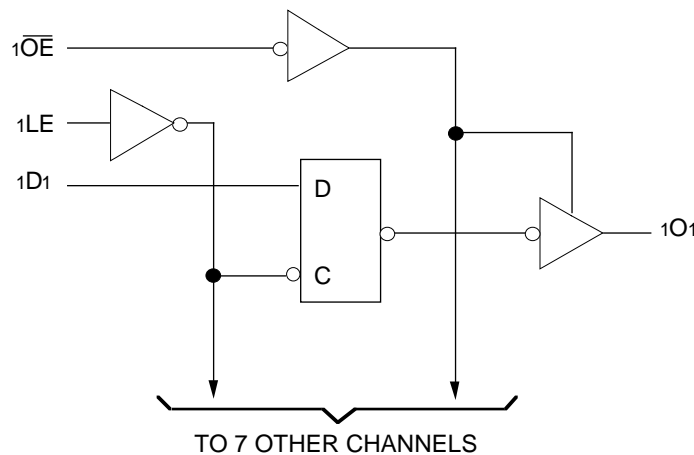

2601 drw 01

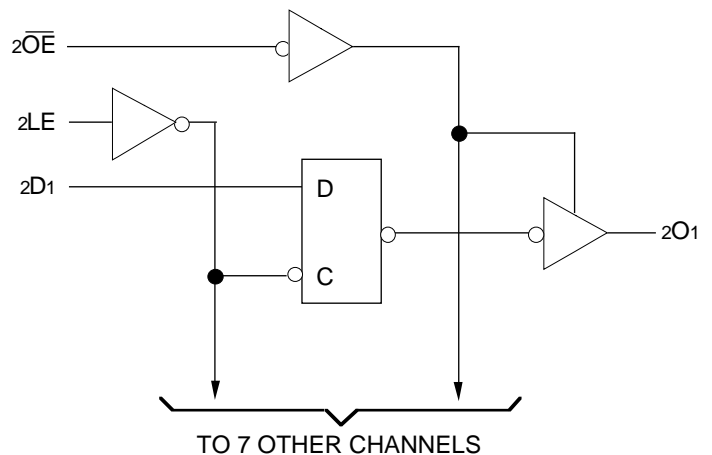

2601 drw 02

The IDT logo is a registered trademark of Integrated Device Technology, Inc.

COMMERCIAL TEMPERATURE RANGE

AUGUST 1996

## PIN CONFIGURATIONS

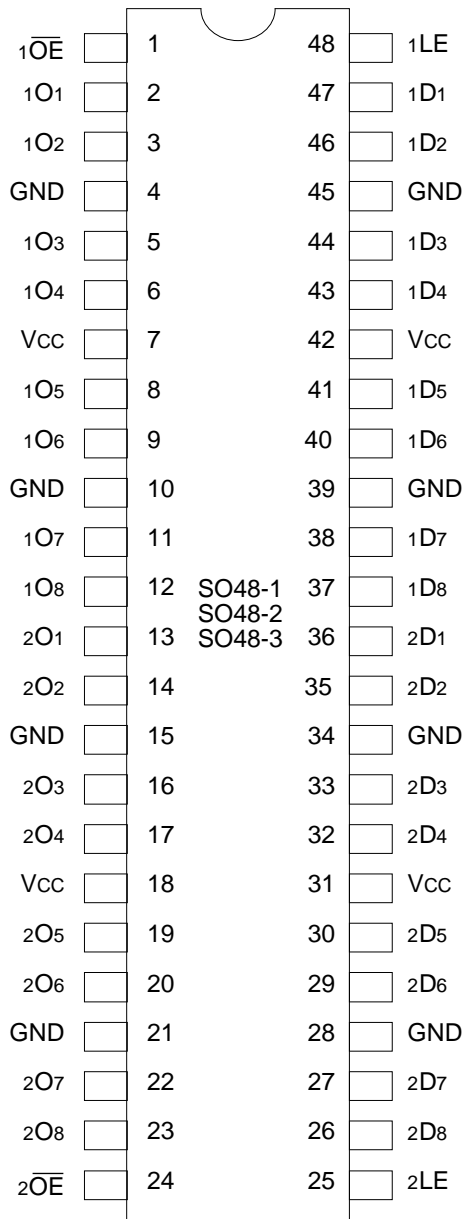

SSOP/  
TSSOP/TVSOP  
TOP VIEW

2601 drw 03

## PIN DESCRIPTION

Pin Names	Description
xDx	Data Inputs
xLE	Latch Enable Input (Active HIGH)
xOE	Output Enable Input (Active LOW)
xOx	3-State Outputs

2601 tbl 01

## ABSOLUTE MAXIMUM RATINGS<sup>(1)</sup>

Symbol	Description	Max.	Unit
VTERM <sup>(2)</sup>	Terminal Voltage with Respect to GND	-0.5 to +4.6	V
VTERM <sup>(3)</sup>	Terminal Voltage with Respect to GND	-0.5 to +7.0	V
VTERM <sup>(4)</sup>	Terminal Voltage with Respect to GND	-0.5 to VCC + 0.5	V
TSTG	Storage Temperature	-65 to +150	°C
IOUT	DC Output Current	-60 to +60	mA

2601 lmk 03

### NOTES:

- Stresses greater than those listed under ABSOLUTE MAXIMUM RATINGS may cause permanent damage to the device. This is a stress rating only and functional operation of the device at these or any other conditions above those indicated in the operational sections of this specification is not implied. Exposure to absolute maximum rating conditions for extended periods may affect reliability.
- VCC terminals.
- Input terminals.
- Output and I/O terminals.

## CAPACITANCE (TA = +25°C, f = 1.0MHz)

Symbol	Parameter <sup>(1)</sup>	Conditions	Typ.	Max.	Unit
CIN	Input Capacitance	VIN = 0V	3.5	6.0	pF
COU	Output Capacitance	VOU = 0V	3.5	8.0	pF

2601 lmk 04

### NOTE:

- This parameter is measured at characterization but not tested.

## FUNCTION TABLE<sup>(1)</sup>

Inputs			Outputs
xDx	xLE	xOE	xOx
H	H	L	H
L	H	L	L
X	X	H	Z

### NOTE:

2601 tbl 02

- H = HIGH Voltage Level  
L = LOW Voltage Level  
X = Don't Care  
Z = High Impedance

## DC ELECTRICAL CHARACTERISTICS OVER OPERATING RANGE

Following Conditions Apply Unless Otherwise Specified:  
Commercial:  $T_A = -40^{\circ}\text{C}$  to  $+85^{\circ}\text{C}$ ,  $V_{CC} = 2.7\text{V}$  to  $3.6\text{V}$

Symbol	Parameter	Test Conditions <sup>(1)</sup>	Min.	Typ. <sup>(2)</sup>	Max.	Unit	
V <sub>IH</sub>	Input HIGH Level (Input pins)	Guaranteed Logic HIGH Level	2.0	—	5.5	V	
	Input HIGH Level (I/O pins)		2.0	—	V <sub>CC</sub> +0.5		
V <sub>IL</sub>	Input LOW Level (Input and I/O pins)	Guaranteed Logic LOW Level	-0.5	—	0.8	V	
I <sub>IH</sub>	Input HIGH Current (Input pins)	V <sub>CC</sub> = Max.	V <sub>I</sub> = 5.5V	—	—	±1	μA
	Input HIGH Current (I/O pins)		V <sub>I</sub> = V <sub>CC</sub>	—	—	±1	
I <sub>IL</sub>	Input LOW Current (Input pins)		V <sub>I</sub> = GND	—	—	±1	
	Input LOW Current (I/O pins)		V <sub>I</sub> = GND	—	—	±1	
I <sub>OZH</sub>	High Impedance Output Current	V <sub>CC</sub> = Max.	V <sub>O</sub> = V <sub>CC</sub>	—	—	±1	μA
I <sub>OZL</sub>	(3-State Output pins)		V <sub>O</sub> = GND	—	—	±1	
V <sub>IK</sub>	Clamp Diode Voltage	V <sub>CC</sub> = Min., I <sub>IN</sub> = -18mA	—	-0.7	-1.2	V	
I <sub>ODH</sub>	Output HIGH Current	V <sub>CC</sub> = 3.3V, V <sub>IN</sub> = V <sub>IH</sub> or V <sub>IL</sub> , V <sub>O</sub> = 1.5V <sup>(3)</sup>	-36	-60	-110	mA	
I <sub>ODL</sub>	Output LOW Current	V <sub>CC</sub> = 3.3V, V <sub>IN</sub> = V <sub>IH</sub> or V <sub>IL</sub> , V <sub>O</sub> = 1.5V <sup>(3)</sup>	50	90	200	mA	
V <sub>OH</sub>	Output HIGH Voltage	V <sub>CC</sub> = Min. V <sub>IN</sub> = V <sub>IH</sub> or V <sub>IL</sub>	I <sub>OH</sub> = -0.1mA	V <sub>CC</sub> -0.2	—	—	V
			I <sub>OH</sub> = -3mA	2.4	3.0	—	
		V <sub>CC</sub> = 3.0V V <sub>IN</sub> = V <sub>IH</sub> or V <sub>IL</sub>	I <sub>OH</sub> = -8mA	2.4 <sup>(5)</sup>	3.0	—	
V <sub>OL</sub>	Output LOW Voltage	V <sub>CC</sub> = Min. V <sub>IN</sub> = V <sub>IH</sub> or V <sub>IL</sub>	I <sub>OL</sub> = 0.1mA	—	—	0.2	V
			I <sub>OL</sub> = 16mA	—	0.2	0.4	
			I <sub>OL</sub> = 24mA	—	0.3	0.55	
		V <sub>CC</sub> = 3.0V V <sub>IN</sub> = V <sub>IH</sub> or V <sub>IL</sub>	I <sub>OL</sub> = 24mA	—	0.3	0.50	
I <sub>OS</sub>	Short Circuit Current <sup>(4)</sup>	V <sub>CC</sub> = Max., V <sub>O</sub> = GND <sup>(3)</sup>	-60	-135	-240	mA	
V <sub>H</sub>	Input Hysteresis	—	—	150	—	mV	
I <sub>CCL</sub> I <sub>CCH</sub> I <sub>CCZ</sub>	Quiescent Power Supply Current	V <sub>CC</sub> = Max., V <sub>IN</sub> = GND or V <sub>CC</sub>	—	0.1	10	μA	

### NOTES:

2601 Ink 05

- For conditions shown as Max. or Min., use appropriate value specified under Electrical Characteristics for the applicable device type.
- Typical values are at V<sub>CC</sub> = 3.3V, +25°C ambient.
- Not more than one output should be tested at one time. Duration of the test should not exceed one second.
- This parameter is guaranteed but not tested.
- V<sub>OH</sub> = V<sub>CC</sub> - 0.6V at rated current.

## POWER SUPPLY CHARACTERISTICS

Symbol	Parameter	Test Conditions <sup>(1)</sup>		Min.	Typ. <sup>(2)</sup>	Max.	Unit
$\Delta I_{CC}$	Quiescent Power Supply Current TTL Inputs HIGH	$V_{CC} = \text{Max.}$	$V_{IN} = V_{CC} - 0.6V^{(3)}$	—	2.0	30	$\mu A$
$I_{CCD}$	Dynamic Power Supply Current <sup>(4)</sup>	$V_{CC} = \text{Max.}$ Outputs Open $\overline{xOE} = \text{GND}$ One Input Toggling 50% Duty Cycle	$V_{IN} = V_{CC}$ $V_{IN} = \text{GND}$	—	50	75	$\mu A / \text{MHz}$
$I_C$	Total Power Supply Current <sup>(6)</sup>	$V_{CC} = \text{Max.}$ Outputs Open $f_i = 10\text{MHz}$ 50% Duty Cycle $\overline{xOE} = \text{GND}$ $xLE = V_{CC}$ One Bit Toggling	$V_{IN} = V_{CC}$ $V_{IN} = \text{GND}$	—	0.5	0.8	mA
			$V_{IN} = V_{CC} - 0.6V$ $V_{IN} = \text{GND}$	—	0.5	0.8	
		$V_{CC} = \text{Max.}$ Outputs Open $f_i = 2.5\text{MHz}$ 50% Duty Cycle $\overline{xOE} = \text{GND}$ $xLE = V_{CC}$ Sixteen Bits Toggling	$V_{IN} = V_{CC}$ $V_{IN} = \text{GND}$	—	2.0	3.0 <sup>(5)</sup>	
			$V_{IN} = V_{CC} - 0.6V$ $V_{IN} = \text{GND}$	—	2.0	3.3 <sup>(5)</sup>	

### NOTES:

- For conditions shown as max. or min., use appropriate value specified under Electrical Characteristics for the applicable device type.
- Typical values are at  $V_{CC} = 3.3V$ ,  $+25^\circ\text{C}$  ambient.
- Per TTL driven input; all other inputs at  $V_{CC}$  or GND.
- This parameter is not directly testable, but is derived for use in Total Power Supply Calculations.
- Values for these conditions are examples of the  $I_C$  formula. These limits are guaranteed but not tested.
- $I_C = I_{QUIESCENT} + I_{INPUTS} + I_{DYNAMIC}$   
 $I_C = I_{CC} + \Delta I_{CC} D_H N_T + I_{CCD} (f_{CP} N_{CP} / 2 + f_i N_i)$   
 $I_{CC} = \text{Quiescent Current } (I_{CCL}, I_{CCH} \text{ and } I_{CCZ})$   
 $\Delta I_{CC} = \text{Power Supply Current for a TTL High Input}$   
 $D_H = \text{Duty Cycle for TTL Inputs High}$   
 $N_T = \text{Number of TTL Inputs at } D_H$   
 $I_{CCD} = \text{Dynamic Current Caused by an Input Transition Pair (HLH or LHL)}$   
 $f_{CP} = \text{Clock Frequency for Register Devices (Zero for Non-Register Devices)}$   
 $N_{CP} = \text{Number of Clock Inputs at } f_{CP}$   
 $f_i = \text{Input Frequency}$   
 $N_i = \text{Number of Inputs at } f_i$

2601 tbl 06

**SWITCHING CHARACTERISTICS OVER OPERATING RANGE<sup>(4)</sup>**

Symbol	Parameter	Condition <sup>(1)</sup>	FCT163373		FCT163373A		FCT163373C		Unit
			Min. <sup>(2)</sup>	Max.	Min. <sup>(2)</sup>	Max.	Min. <sup>(2)</sup>	Max.	
tPLH tPHL	Propagation Delay xDx to xOx	CL = 50pF RL = 500Ω	1.5	8.0	1.5	5.2	1.5	4.2	ns
tPLH tPHL	Propagation Delay xLE to xOx		2.0	13.0	2.0	8.5	2.0	5.5	ns
tpZH tpZL	Output Enable Time		1.5	12.0	1.5	6.5	1.5	5.5	ns
tPHZ tPLZ	Output Disable Time		1.5	7.5	1.5	5.5	1.5	5.0	ns
tsu	Set-up Time HIGH or LOW, xDx to xLE		2.0	—	2.0	—	2.0	—	ns
th	Hold Time HIGH or LOW, xDx to xLE		1.5	—	1.5	—	1.5	—	ns
tw	xLE Pulse Width HIGH		6.0	—	5.0	—	5.0	—	ns
tsk(o)	Output Skew <sup>(3)</sup>		—	0.5	—	0.5	—	0.5	ns

**NOTES:**

1. See test circuit and waveforms.
2. Minimum limits are guaranteed but not tested on Propagation Delays.
3. Skew between any two outputs, of the same package, switching in the same direction. This parameter is guaranteed by design.
4. Propagation Delays and Enable/Disable times are with  $V_{CC} = 3.3V \pm 0.3V$ , Normal Range. For  $V_{CC} = 2.7V$  to  $3.6V$ , Extended Range, all Propagation Delays and Enable/Disable times should be degraded by 20%.

2601 tbl 07

## TEST CIRCUITS AND WAVEFORMS

### TEST CIRCUITS FOR ALL OUTPUTS

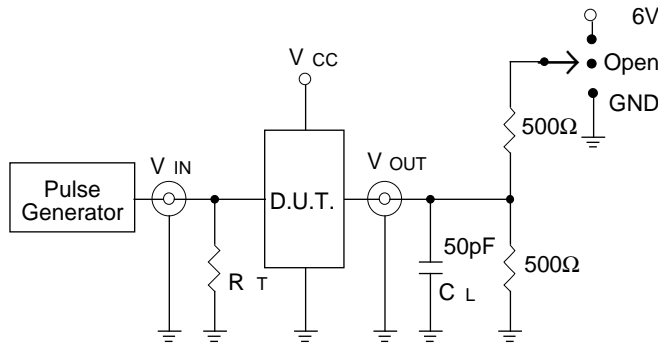

2601 drw 05

### SWITCH POSITION

Test	Switch
Open Drain Disable Low Enable Low	6V
Disable High Enable High	GND
All Other tests	Open

#### DEFINITIONS:

$C_L$  = Load capacitance: includes jig and probe capacitance.  
 $R_T$  = Termination resistance: should be equal to  $Z_{OUT}$  of the Pulse Generator.

2601 Ink 08

### SET-UP, HOLD AND RELEASE TIMES

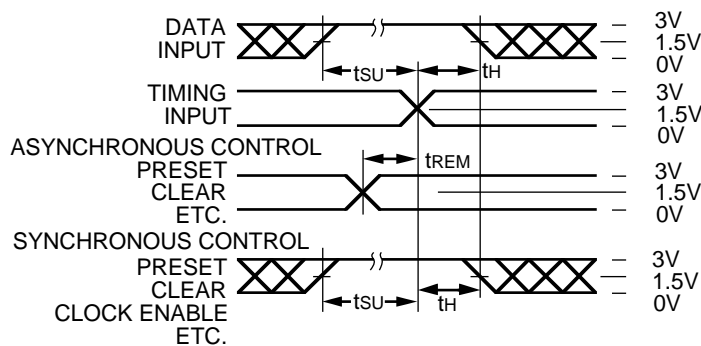

2601 drw 06

### PULSE WIDTH

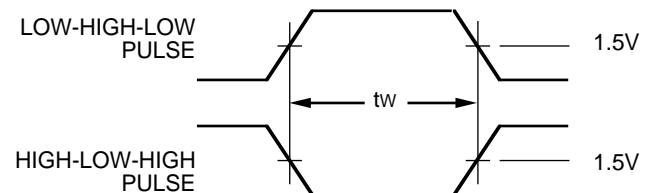

2601 drw 07

### PROPAGATION DELAY

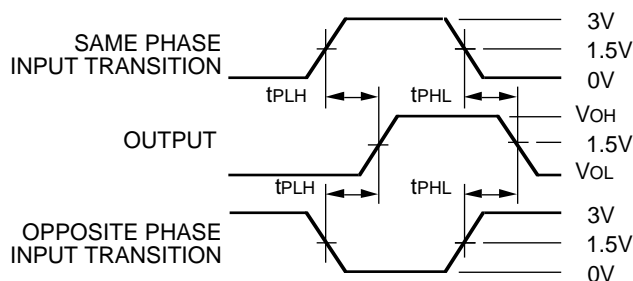

2601 drw 08

### ENABLE AND DISABLE TIMES

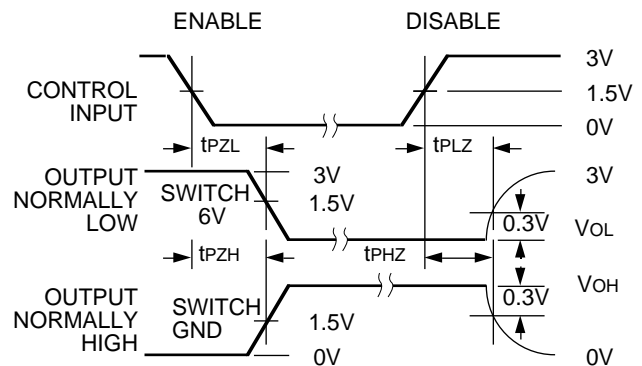

2601 drw 09

#### NOTES:

1. Diagram shown for input Control Enable-LOW and input Control Disable-HIGH.
2. Pulse Generator for All Pulses: Rate  $\leq 1.0\text{MHz}$ ;  $t_f \leq 2.5\text{ns}$ ;  $t_r \leq 2.5\text{ns}$ .
3. If  $V_{CC}$  is below 3V, input voltage swings should be adjusted not to exceed  $V_{CC}$ .

## ORDERING INFORMATION

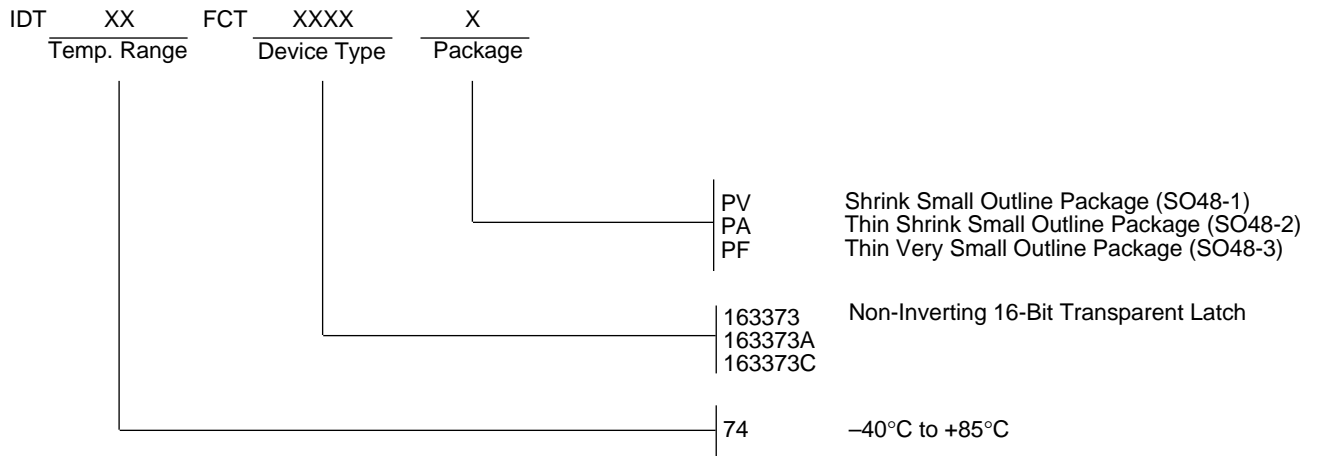

2601 drw 10

This datasheet has been downloaded from:

[www.DatasheetCatalog.com](http://www.DatasheetCatalog.com)

Datasheets for electronic components.



LittleDiode supplies new, hard to find or obsolete electronic components and semiconductors all over the world.

With over two million different components listed you are sure to find the part you need.

Feel free to visit us today at our online store:

**[LittleDiode.com](http://LittleDiode.com)**

Looking forward to providing you with the best possible service.