



# HIGH-PERFORMANCE CMOS BUS INTERFACE LATCH

**IDT74FCT841A/B**

## FEATURES:

- Equivalent to AMD's Am29841 bipolar registers in pinout/ function, speed, and output drive over full temperature and voltage supply extremes
- IDT74FCT841A equivalent to FAST™ speed
- IDT74FCT841B 25% faster than FAST
- Buffered common latch enable, clear and present inputs
- I<sub>OL</sub> = 48mA
- Clamp diodes on all inputs for ringing suppression
- CMOS power levels (1mW typ. static)
- TTL input and output level compatible
- CMOS output level compatible
- Substantially lower input current levels than AMD's bipolar Am29800 series (5μA max.)
- Available in SOIC package

## DESCRIPTION:

The IDT74FCT800 series is built using an advanced dual metal CMOS technology.

The IDT74FCT840 series bus interface latches are designed to eliminate the extra packages required to buffer existing latches and provide extra data width for wider address/data paths or buses carrying parity. The IDT74FCT841 is a buffered, 10-bit wide version of the popular '373 function.

All of the IDT74FCT800 high-performance interface family are designed for high-capacitance load drive capability, while providing low-capacitance bus loading at both inputs and outputs. All inputs have clamp diodes and all outputs are designed for low-capacitance bus loading in the high-impedance state.

## FUNCTIONAL BLOCK DIAGRAM

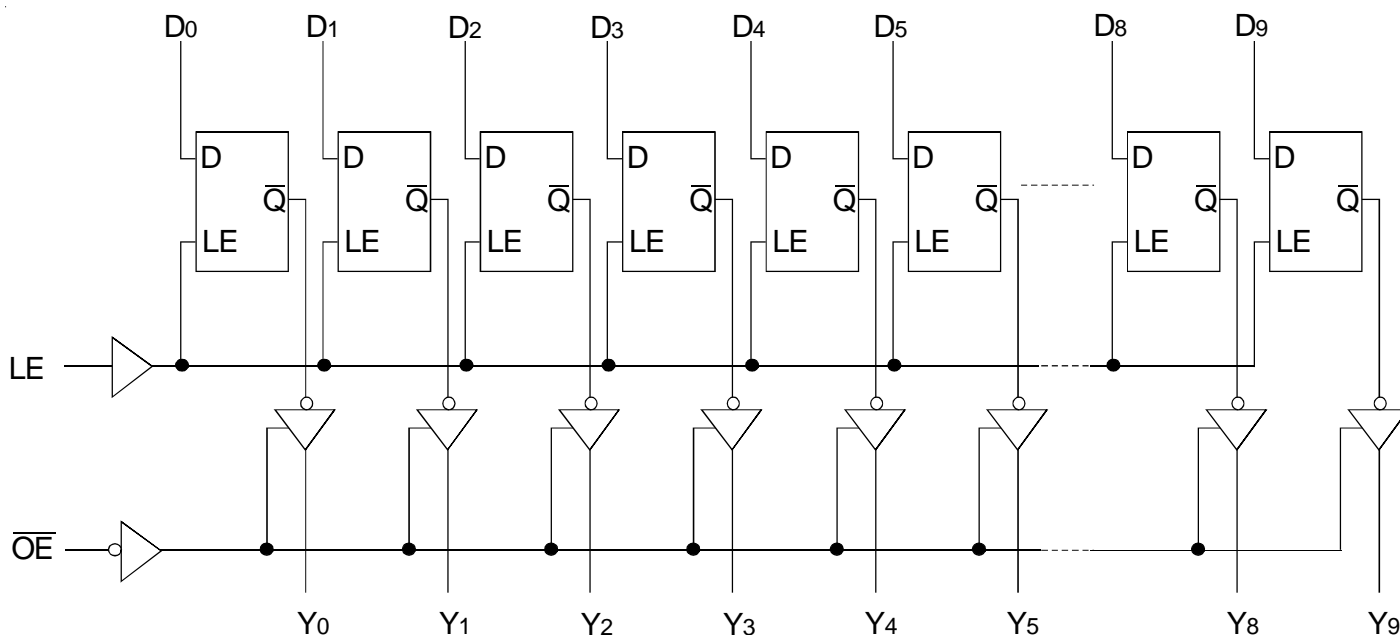

## PIN CONFIGURATION

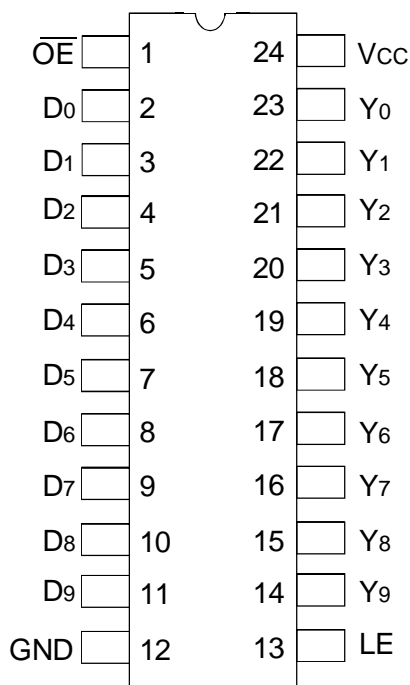

## ABSOLUTE MAXIMUM RATINGS<sup>(1)</sup>

Symbol	Description	Max	Unit
V <sub>TERM</sub> <sup>(2)</sup>	Terminal Voltage with Respect to GND	-0.5 to +7	V
V <sub>TERM</sub> <sup>(3)</sup>	Terminal Voltage with Respect to GND	-0.5 to V <sub>CC</sub>	V
T <sub>A</sub>	Operating Temperature	0 to +70	°C
T <sub>BIAS</sub>	Temperature under BIAS	-55 to +125	°C
T <sub>STG</sub>	Storage Temperature	-55 to +125	°C
P <sub>T</sub>	Power Dissipation	0.5	W
I <sub>OUT</sub>	DC Output Current	120	mA

### NOTES:

- Stresses greater than those listed under ABSOLUTE MAXIMUM RATINGS may cause permanent damage to the device. This is a stress rating only and functional operation of the device at these or any other conditions above those indicated in the operational sections of this specification is not implied. Exposure to absolute maximum rating conditions for extended periods may affect reliability. No terminal voltage may exceed V<sub>CC</sub> by +0.5V unless otherwise noted.
- Input and V<sub>CC</sub> terminals only.
- Output and I/O terminals only.

## CAPACITANCE (T<sub>A</sub> = +25°C, F = 1.0MHz)

Symbol	Parameter <sup>(1)</sup>	Conditions	Typ.	Max.	Unit
C <sub>IN</sub>	Input Capacitance	V <sub>IN</sub> = 0V	6	10	pF
C <sub>OUT</sub>	Output Capacitance	V <sub>OUT</sub> = 0V	8	12	pF

### NOTE:

- This parameter is measured at characterization but not tested.

## PIN DESCRIPTION

Pin Names	I/O	Description
D <sub>x</sub>	I	Latch Data Inputs
LE	I	Latch Enable Input. The latches are transparent when LE is HIGH. Input data is latched on the HIGH-to-LOW transition.
Y <sub>x</sub>	O	3-State Latch Outputs
$\overline{OE}$	I	Output Enable Control. When $\overline{OE}$ is LOW, the outputs are enabled. When $\overline{OE}$ is HIGH, the outputs Y <sub>x</sub> are in high-impedance (off) state.

## FUNCTION TABLE<sup>(1)</sup>

Inputs			Internal	Output	Function
$\overline{OE}$	LE	D <sub>x</sub>	Q <sub>x</sub>	Y <sub>x</sub>	
H	X	X	X	Z	High Z
H	H	L	L	Z	High Z
H	H	H	H	Z	High Z
H	L	X	NC	Z	Latched (High Z)
L	H	L	L	L	Transparent
L	H	H	H	H	Transparent
L	L	X	NC	NC	Latched
H	L	X	L	Z	Latched (High Z)
H	L	X	H	Z	Latched (High Z)

### NOTE:

- H = HIGH Voltage Level  
X = Don't Care  
L = LOW Voltage Level  
Z = High-Impedance  
NC = No Change

## DC ELECTRICAL CHARACTERISTICS OVER OPERATING RANGE

Following Conditions Apply Unless Otherwise Specified:  $V_{LC} = 0.2V$ ;  $V_{HC} = V_{CC} - 0.2V$

Commercial:  $T_A = 0^\circ C$  to  $+70^\circ C$ ,  $V_{CC} = 5.0V \pm 5\%$

Symbol	Parameter	Test Conditions <sup>(1)</sup>	Min.	Typ. <sup>(2)</sup>	Max.	Unit	
$V_{IH}$	Input HIGH Level	Guaranteed Logic HIGH Level	2	—	—	V	
$V_{IL}$	Input LOW Level	Guaranteed Logic LOW Level	—	—	0.8	V	
$I_{IH}$	Input HIGH Current	$V_{CC} = \text{Max.}$	$V_I = V_{CC}$	—	—	5	$\mu A$
$I_{IL}$	Input LOW Current		$V_I = 2.7V$	—	—	5 <sup>(4)</sup>	
			$V_I = 0.5V$	—	—	-5 <sup>(4)</sup>	
$I_{OZH}$	Off State (High Impedance) Output Current	$V_{CC} = \text{Max.}$	$V_O = V_{CC}$	—	—	10	$\mu A$
			$V_O = 2.7V$	—	—	10 <sup>(4)</sup>	
			$V_O = 0.5V$	—	—	-10 <sup>(4)</sup>	
			$V_O = GND$	—	—	-10	
$V_{IK}$	Clamp Diode Voltage	$V_{CC} = \text{Min.}, I_{IN} = -18mA$	—	-0.7	-1.2	V	
$I_{OS}$	Short Circuit Current	$V_{CC} = \text{Max.}, V_O = GND$ <sup>(3)</sup>	-75	-120	—	mA	
$V_{OH}$	Output HIGH Voltage	$V_{CC} = 3V, V_{IN} = V_{LC} \text{ or } V_{HC}, I_{OH} = -32\mu A$	$V_{HC}$	$V_{CC}$	—	V	
		$V_{CC} = \text{Min}$	$I_{OH} = -300\mu A$	$V_{HC}$	$V_{CC}$		
		$V_{IN} = V_{IH} \text{ or } V_{IL}$	$I_{OH} = -24mA$	2.4	4.3		
$V_{OL}$	Output LOW Voltage	$V_{CC} = 3V, V_{IN} = V_{LC} \text{ or } V_{HC}, I_{OL} = 300\mu A$	—	GND	$V_{LC}$	V	
		$V_{CC} = \text{Min}$	$I_{OL} = 300\mu A$	—	GND		
		$V_{IN} = V_{IH} \text{ or } V_{IL}$	$I_{OL} = 48mA$	—	0.3		0.5

### NOTES:

1. For conditions shown as Min. or Max., use appropriate value specified under Electrical Characteristics for the applicable device type.
2. Typical values are at  $V_{CC} = 5.0V$ ,  $+25^\circ C$  ambient and maximum loading.
3. Not more than one output should be tested at one time. Duration of the test should not exceed one second.
4. This parameter is guaranteed but not tested.

## POWER SUPPLY CHARACTERISTICS

$V_{LC} = 0.2V$ ;  $V_{HC} = V_{CC} - 0.2V$

Symbol	Parameter	Test Conditions <sup>(1)</sup>		Min.	Typ. <sup>(2)</sup>	Max.	Unit
I <sub>CC</sub>	Quiescent Power Supply Current	V <sub>CC</sub> = Max. V <sub>IN</sub> ≥ V <sub>HC</sub> ; V <sub>IN</sub> ≤ V <sub>LC</sub>		—	0.2	1.5	mA
ΔI <sub>CC</sub>	Quiescent Power Supply Current TTL Inputs HIGH	V <sub>CC</sub> = Max. V <sub>IN</sub> = 3.4V <sup>(3)</sup>		—	0.5	2	mA
I <sub>CCD</sub>	Dynamic Power Supply Current <sup>(4)</sup>	V <sub>CC</sub> = Max. Outputs Open $\overline{OE}$ = GND LE = V <sub>CC</sub> One Input Toggling 50% Duty Cycle	V <sub>IN</sub> ≥ V <sub>HC</sub> V <sub>IN</sub> ≤ V <sub>LC</sub>	—	0.15	0.25	mA/ MHz
I <sub>C</sub>	Total Power Supply Current <sup>(6)</sup>	V <sub>CC</sub> = Max. Outputs Open f <sub>i</sub> = 10MHz  50% Duty Cycle $\overline{OE}$ = GND LE = V <sub>CC</sub> One Bit Toggling	V <sub>IN</sub> ≥ V <sub>HC</sub> V <sub>IN</sub> ≤ V <sub>LC</sub> (FCT)	—	1.7	4	mA
			V <sub>IN</sub> = 3.4V V <sub>IN</sub> = GND	—	2	5	
		V <sub>CC</sub> = Max. Outputs Open f <sub>i</sub> = 2.5MHz  50% Duty Cycle $\overline{OE}$ = GND LE = V <sub>CC</sub> Eight Bits Toggling	V <sub>IN</sub> ≥ V <sub>HC</sub> V <sub>IN</sub> ≤ V <sub>LC</sub> (FCT)	—	3.2	6.5 <sup>(5)</sup>	
			V <sub>IN</sub> = 3.4V V <sub>IN</sub> = GND	—	5.2	14.5 <sup>(5)</sup>	

### NOTES:

1. For conditions shown as Min. or Max., use appropriate value specified under Electrical Characteristics for the applicable device type.

2. Typical values are at V<sub>CC</sub> = 5.0V, +25°C ambient.

3. Per TTL driven input (V<sub>IN</sub> = 3.4V). All other inputs at V<sub>CC</sub> or GND.

4. This parameter is not directly testable, but is derived for use in Total Power Supply Calculations.

5. Values for these conditions are examples of ΔI<sub>CC</sub> formula. These limits are guaranteed but not tested.

6. I<sub>C</sub> = I<sub>QUIESCENT</sub> + I<sub>INPUTS</sub> + I<sub>DYNAMIC</sub>

$$I_C = I_{CC} + \Delta I_{CC} D_H N_T + I_{CCD} (f_{CP}/2 + f_i N_i)$$

I<sub>CC</sub> = Quiescent Current

ΔI<sub>CC</sub> = Power Supply Current for a TTL High Input (V<sub>IN</sub> = 3.4V)

D<sub>H</sub> = Duty Cycle for TTL Inputs High

N<sub>T</sub> = Number of TTL Inputs at D<sub>H</sub>

I<sub>CCD</sub> = Dynamic Current caused by an Input Transition Pair (HLH or LHL)

f<sub>CP</sub> = Clock Frequency for register devices (zero for non-register devices)

f<sub>i</sub> = Input Frequency

N<sub>i</sub> = Number of Inputs at f<sub>i</sub>

All currents are in milliamps and all frequencies are in megahertz.

SWITCHING CHARACTERISTICS OVER OPERATING RANGE

Symbol	Parameter	Condition <sup>(1)</sup>	74FCT841A		74FCT841B		Unit
			Min. <sup>(2)</sup>	Max.	Min. <sup>(2)</sup>	Max.	
t <sub>PLH</sub> t <sub>PHL</sub>	Propagation Delay Dx to Yx (LE = HIGH)	CL = 50pF RL = 500Ω	1.5	9	1.5	6.5	ns
		CL = 300pF <sup>(4)</sup> RL = 500Ω	1.5	13	1.5	13	
t <sub>PLH</sub> t <sub>PHL</sub>	Propagation Delay LE to Yx	CL = 50pF RL = 500Ω	1.5	12	1.5	8	ns
		CL = 300pF <sup>(4)</sup> RL = 500Ω	1.5	16	1.5	15.5	
t <sub>PZH</sub> t <sub>PZL</sub>	Output Enable Time, $\overline{OE}$ to Yx	CL = 50pF RL = 500Ω	1.5	11.5	1.5	8	ns
		CL = 300pF <sup>(4)</sup> RL = 500Ω	1.5	23	1.5	14	
t <sub>PHZ</sub> t <sub>PLZ</sub>	Output Disable Time, $\overline{OE}$ to Yx	CL = 5pF <sup>(4)</sup> RL = 500Ω	1.5	7	1.5	6	ns
		CL = 50pF RL = 500Ω	1.5	18	1.5	7	
t <sub>SU</sub>	Data to LE Set-up Time	CL = 50pF	2.5	—	2.5	—	ns
t <sub>H</sub>	Data to LE Hold Time	RL = 500Ω	2.5	—	2.5	—	ns
t <sub>W</sub>	LE Pulse Width HIGH <sup>(3)</sup>		4	—	4	—	ns

NOTES:

1. See test circuit and waveforms.
2. Minimum limits are guaranteed but not tested on Propagation Delays.
3. These parameters are guaranteed but not tested.
4. This condition is guaranteed but not tested.

TEST CIRCUITS AND WAVEFORMS

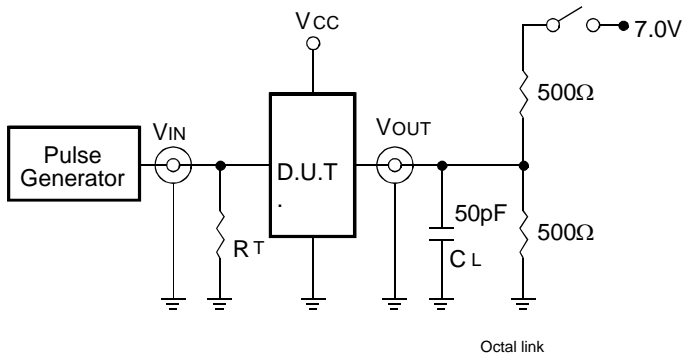

Test Circuits for All Outputs

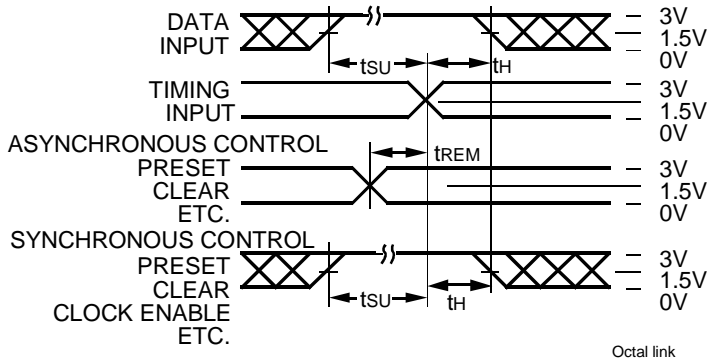

Set-Up, Hold, and Release Times

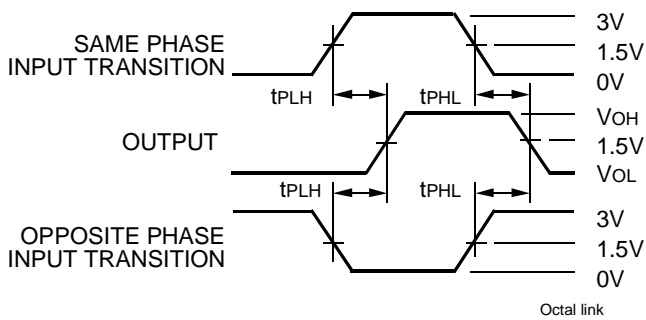

Propagation Delay

SWITCH POSITION

Test	Switch
Open Drain Disable Low Enable Low	Closed
All Other Tests	Open

DEFINITIONS:

CL = Load capacitance: includes jig and probe capacitance.  
RT = Termination resistance: should be equal to ZOUT of the Pulse Generator.

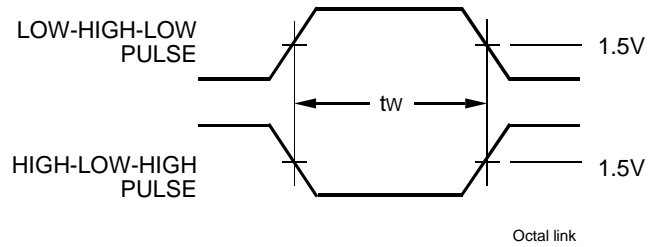

Pulse Width

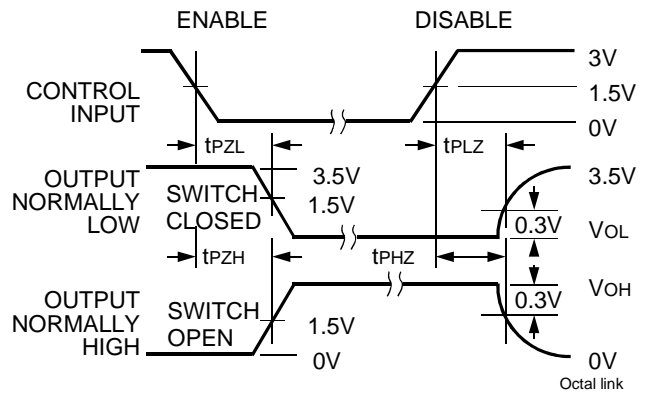

Enable and Disable Times

NOTES:

- Diagram shown for input Control Enable-LOW and input Control Disable-HIGH.
- Pulse Generator for All Pulses: Rate ≤ 1.0MHz; Zo ≤ 50Ω; tr ≤ 2.5ns; tr ≤ 2.5ns.





LittleDiode supplies new, hard to find or obsolete electronic components and semiconductors all over the world.

With over two million different components listed you are sure to find the part you need.

Feel free to visit us today at our online store:

[LittleDiode.com](http://LittleDiode.com)

Looking forward to providing you with the best possible service.