

FEATURES

- On-State Current, 300 mA
- Zero Voltage Crossing
- Blocking Voltage, 800 V
- Isolation Test Voltage 5300 VACRMS
- High Input Sensitivity
IFT=2 mA, PF=1.0
IFT=5 mA, PF≤1.0
- High Static dv/dt 10,000 V/μs
- Inverse Parallel SCRs Provide Commutating dv/dt >10K V/μs
- Very Low Leakage <10 μA
- Small 6-Pin DIP Package
- Underwriters Lab File #E52744
- VDE Approval #0884 (Optional with Option 1, Add -X001 Suffix)

Maximum Ratings

Emitter

Reverse Voltage	6 V
Forward Current	60 mA
Surge Current	2.5 A
Thermal Resistance	750 °C/W
Derate from 25°C	1.33 mW/°C

Detector

Peak Off-state Voltage	800 V
Peak Reverse Voltage	800 V
RMS On-state Current	300 mA
Single Cycle Surge	3 A
Thermal Resistance	125 °C/W
Total Power Dissipation	500 mW
Derate from 25°C	6.6 mW/°C

Package

Isolation Test Voltage (between emitter and detector, climate per DIN 40046, part 2, Nov. 74 (t=1 min.)	5300 VAC _{RMS}
Pollution Degree (DIN VDE 0109)	2
Creepage Distance	≥7 mm
Clearance	≥7 mm
Comparative Tracking Index per DIN IEC 112/VDE 0303 part 1, Group IIIa per DIN VDE 6110	≥175
Isolation Resistance	
V _{IO} =500 V, T _A =25°C	≥10 ¹² Ω
V _{IO} =500 V, T _A =100°C	≥10 ¹¹ Ω
Storage Temperature Range	-55°C to +125°C
Ambient Temperature Range	-55°C to +100°C
Soldering Temperature (max. ≤10 sec. dip soldering ≥0.5 mm from case bottom)	260°C

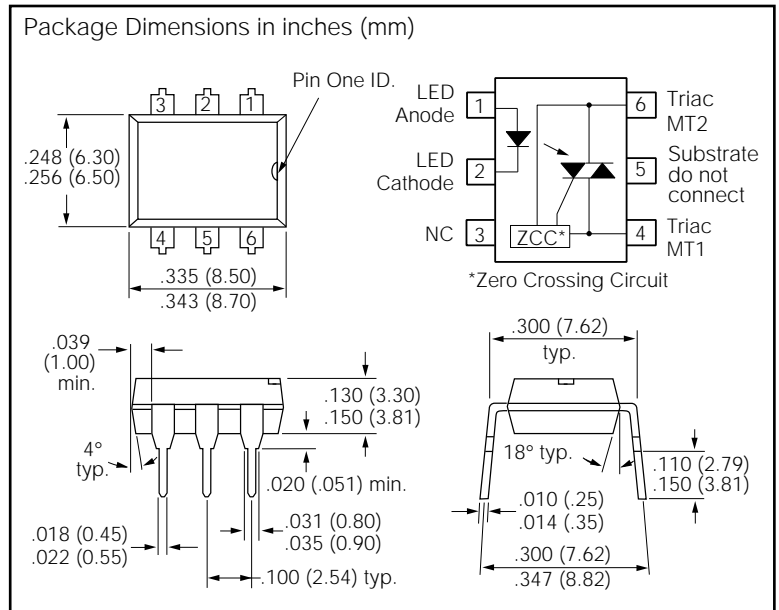

DESCRIPTION

The IL4108 consists of a GaAs IRLED optically coupled to a photosensitive zero crossing TRIAC network. The TRIAC consists of two inverse parallel connected monolithic SCRs. These three semiconductors are assembled in a six pin 0.3 inch dual in-line package, using high insulation double molded, over/under leadframe construction.

High input sensitivity is achieved by using an emitter follower phototransistor and a cascaded SCR predriver resulting in an LED trigger current of less than 2 mA (DC).

The IL4108 uses two discrete SCRs resulting in a commutating dv/dt greater than 10KV/μs. The use of a proprietary dv/dt clamp results in a static dv/dt of greater than 10KV/μs. This clamp circuit has a MOSFET that is enhanced when high dv/dt spikes occur between MT1 and MT2 of the TRIAC. When conducting, the FET clamps the base of the phototransistor, disabling the first stage SCR predriver.

The zero cross line voltage detection circuit consists of two enhancement MOSFETS and a photodiode. The inhibit voltage of the network is determined by the enhancement voltage of the N-channel FET. The P-channel FET is enabled by a photocurrent source that permits the FET to conduct the main voltage to gate on the N-channel FET. Once the main voltage can enable the N-channel, it clamps the base of the phototransistor, disabling the first stage SCR predriver.

The 800V blocking voltage permits control of off-line voltages up to 240VAC, with a safety factor of more than two, and is sufficient for as much as 380VAC.

The IL4108 isolates low-voltage logic from 120, 240, and 380 VAC lines to control resistive, inductive, or capacitive loads including motors, solenoids, high current thyristors or TRIAC and relays.

Applications include solid-state relays, industrial controls, office equipment, and consumer appliances.

Electrical Characteristics

Parameter	Symbol	Min.	Typ.	Max.	Unit	Condition
Emitter						
Forward Voltage	V_F		1.16	1.35	V	$I_F=10\text{ mA}$
Breakdown Voltage	V_{BR}	6	30		V	$I_R=10\text{ }\mu\text{A}$
Reverse Current	I_R		0.1	10	μA	$V_R=6\text{ V}$
Capacitance	C_0		25		pF	$V_F=0\text{ V}$, $f=1\text{ MHz}$
Thermal Resistance, Junction to Lead	R_{THJL}		750		$^{\circ}\text{C/W}$	
Output Detector						
Repetitive Peak Off-state Voltage	V_{DRM}	800			V	$I_{DRM}=100\text{ }\mu\text{A}$
Off-state Voltage	$V_{D(RMS)}$	565			V	$I_{D(RMS)}=70\text{ }\mu\text{A}$
Off-state Current	$I_{D(RMS)1}$		10	100	μA	$V_D=800\text{ V}$, $T_A=100^{\circ}\text{C}$, $I_F=0\text{ mA}$
Off-state Current	$I_{D(RMS)2}$			200	μA	$V_D=800\text{ V}$, $I_F=\text{Rated } I_{FT}$
On-state Voltage	V_{TM}		1.7	3	V	$I_T=300\text{ mA}$
On-state Current	I_{TM}			300	mA	$PF=1.0$, $V_{T(RMS)}=1.7\text{ V}$
Surge (Non-repetitive On-state Current)	I_{TSM}			3	A	$f=50\text{ Hz}$
Trigger Current 1	I_{FT1}			2.0	mA	$V_D=5\text{ V}$
Trigger Current 2	I_{FT2}			6.0	mA	$V_{op}=220\text{ V}$, $f=50\text{ Hz}$, $T_j=100^{\circ}\text{C}$, $t_{pF}>10\text{ ms}$
Trigger Current Temperature Gradient	$\frac{\Delta I_{FT1}}{\Delta T_j}$ $\frac{\Delta I_{FT2}}{\Delta T_j}$		7 7	14 14	$\mu\text{A/K}$ $\mu\text{A/K}$	
Inhibit Voltage Temperature Gradient	$\frac{\Delta V_{DINH}}{\Delta T_j}$		-20		mV/K	
Off-state Current in Inhibit State	I_{DINH}		50	200	μA	$I_F=I_{FT1}$, V_{DRM}
Capacitance between Input and Output Circuit	C_{IO}		2.0		pF	$V_D=0$, $f=1\text{ kHz}$
Holding Current	I_H		65	500	μA	
Latching Current	I_L		5		mA	$V_T=2.2\text{ V}$
Zero Cross Inhibit Voltage	V_{IH}		15	25	V	$I_F=\text{Rated } I_{FT}$
Turn-on Time	t_{ON}		35		μs	$V_{RM}=V_{DM}=565\text{ VAC}$
Turn-off Time	t_{OFF}		50		μs	$PF=1.0$, $I_T=300\text{ mA}$
Critical Rate of Rise of Off-State Voltage	$\frac{dv}{dt}_{cr}$ $\frac{dv}{dt}_{cr}$	10000 5000			V/ μs V/ μs	$V_D=0.67 V_{DRM}$, $T_j=25^{\circ}\text{C}$ $T_j=80^{\circ}\text{C}$
Critical Rate of Rise of Voltage at Current Commutation	$\frac{dv}{dt}_{crq}$ $\frac{dv}{dt}_{crq}$	10000 5000			V/ μs V/ μs	$V_D=0.67 V_{DRM}$, $\frac{di}{dt}_{crq}<15\text{ A/ms}$ $T_j=25^{\circ}\text{C}$ $T_j=80^{\circ}\text{C}$
Critical Rate of Rise of On-state Current	$\frac{di}{dt}_{cr}$			8	A/ μs	
Thermal Resistance, Junction to Lead	R_{THJL}		150		$^{\circ}\text{C/W}$	
Package						
Critical Rate of Rise of Coupled Input/Output Voltage	$\frac{dv_{(IO)}}{dt}$		1000 0		V/ μs	$I_T=0\text{ A}$, $V_{RM}=V_{DM}=565\text{ VAC}$
Common Mode Coupling Capacitor	C_{CM}		0.01		pF	
Package Capacitance	C_{IO}		0.8		pF	$f=1\text{ MHz}$, $V_{IO}=0\text{ V}$



LittleDiode supplies new, hard to find or obsolete electronic components and semiconductors all over the world.

With over two million different components listed you are sure to find the part you need.

Feel free to visit us today at our online store:

LittleDiode.com

Looking forward to providing you with the best possible service.