

INT202

Low-side Driver IC

Low-side Drive and High-side Control for Simultaneous Conduction



Product Highlights

5 V CMOS Compatible Control Inputs

- Combines logic inputs for low and high-side drives
- Schmidt-triggered inputs for noise immunity

Built-in High-voltage Level Shifters

- Integrated level shifters simplify high-side interface
- Can withstand up to 800 V for direct interface to the INT201 high-side driver
- Pulsed high-voltage level shifters reduce power consumption

Gate Drive Output for an External MOSFET

- Provides 300 mA sink/150 mA source current
- Can drive MOSFET gate at up to 15 V
- External MOSFET allows flexibility in design for various motor sizes

Built-in Protection Features

- UV lockout

Description

The INT202 Low-side driver IC provides gate drive for an external low-side MOSFET switch and high-side level shifting. When used in conjunction with the INT201 high-side driver, the INT202 provides a simple, cost-effective interface between low-voltage control logic and high-voltage loads. The INT202 is designed to be used with rectified 110 V or 220 V supplies. Both high side and low side switches can be controlled independently from ground-referenced 5 V logic inputs on the low side driver.

Pulsed level shifting saves power and provides enhanced noise immunity. The circuit is powered from a nominal 15 V supply to provide adequate gate drive for external N-channel MOSFETs.

Applications include switched reluctance motor drives. The INT202 can also be used to implement multi-phase configurations.

The INT202 is available in 8-pin plastic DIP and SOIC packages.

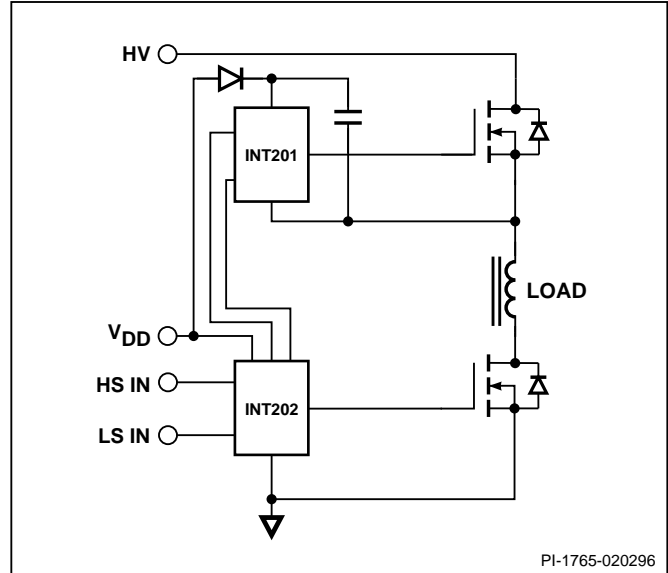

Figure 1. Typical Application

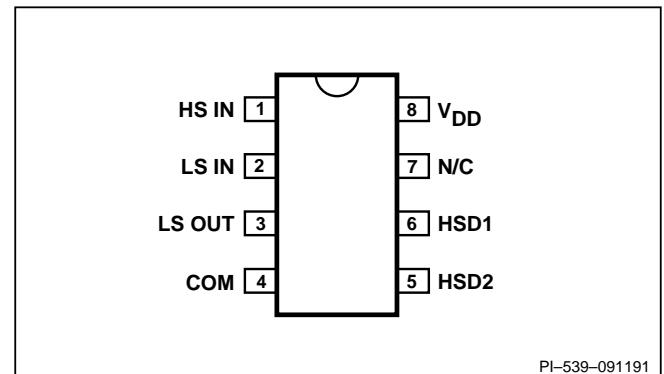

Figure 2. Pin Configuration.

ORDERING INFORMATION		
PART NUMBER	PACKAGE OUTLINE	ISOLATION VOLTAGE
INT202PFI1	PO8A	600 V
INT202TFI1	TO8A	600 V
INT202PFI2	PO8A	800 V
INT202TFI2	TO8A	800 V

Pin Functional Description

Pin 1:

Active-high logic-level input **HS IN** controls the pulse circuit which signals the INT201 high-side driver.

Pin 2:

Active-high logic level input **LS IN** controls the low side driver output.

Pin 3:

LS OUT is the driver output which controls the low-side MOSFET.

Pin 4:

COM connection; analog reference point for the circuit.

Pin 5:

Level shift output **HSD 2** signals the high-side driver to turn off. One short, precise pulse is sent on each positive transition of **HS IN**.

Pin 6:

Level shift output **HSD 1** signals the high-side driver to turn on. Two short, precise pulses are sent on each negative transition of **HS IN**.

Pin 7:

N/C for creepage distance.

Pin 8:

V_{DD} supplies power to the logic, high-side interface, and low-side driver.

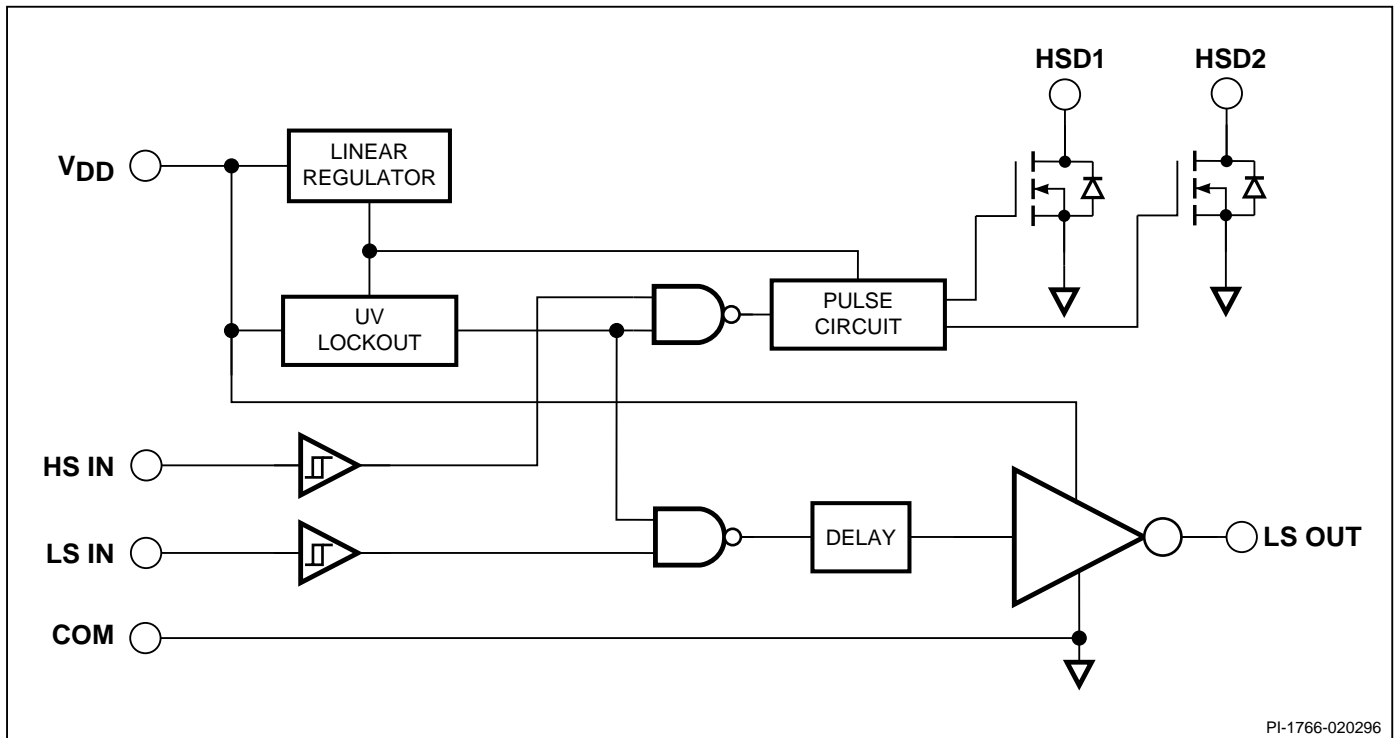

Figure 3. Functional Block Diagram of the INT202

INT202 Functional Description

5 V Regulator

The 5 V linear regulator circuit provides the supply voltage for the control logic and high-voltage level shift circuit. This allows the logic section to be directly compatible with 5 V CMOS logic without the need of an external 5 V supply.

Undervoltage Lockout

The undervoltage lockout circuit disables the LS OUT pin and both HSD pins whenever the V_{DD} power supply falls below typically 9.0 V, and maintains this condition until the V_{DD} power supply rises above typically 9.35 V. This guarantees that both MOSFETs will remain off during power-up or fault conditions.

HSD1/HSD2

The HSD1 and HSD2 outputs are connected to integrated high-voltage N-channel MOSFET transistors which perform the level-shifting function for communication to the high-side driver. Controlled current capability allows the drain voltage to float with the high-side driver. Two individual channels produce a true differential communication channel for accurately controlling the high-side driver in the presence of fast moving high-voltage waveforms.

Pulse Circuit

The pulse circuit provides the two high-voltage level shifters with precise timing signals. Two pulses are sent over HSD1 to signal the high-side driver to turn on. One pulse is sent over HSD2 to signal the high-side driver to turn off. The combination of differential communication with the precise timing provides maximum immunity to noise.

Driver

The CMOS drive circuit provides drive power to the gate of the MOSFET used on the low side of the half bridge circuit. The driver consists of a CMOS buffer capable of driving an external transistor gate at up to 15 V.

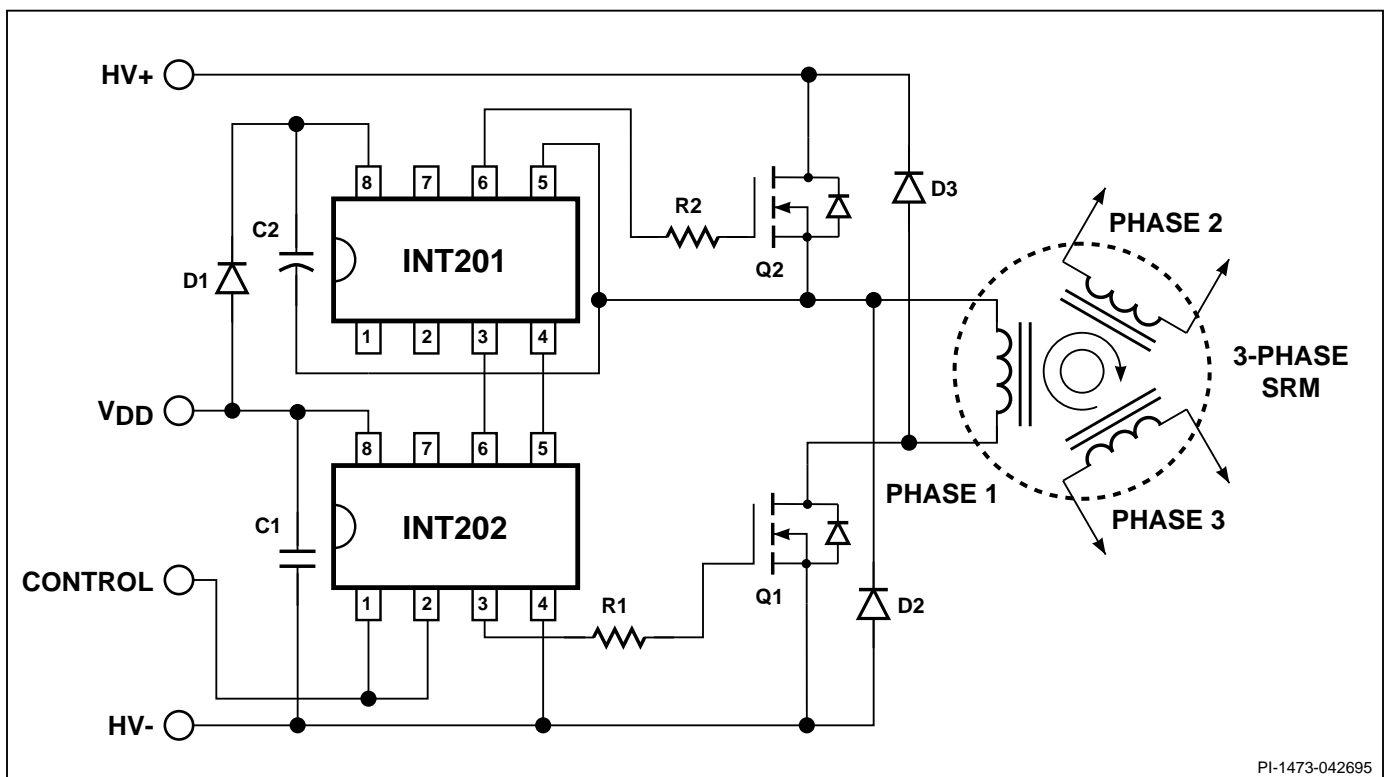

PI-1473-042695

Figure 4. Using the INT202 and INT201 to Drive a Switched Reluctance Motor.

General Circuit Operation

The three-phase switched reluctance motor drive circuit shown in Figure 4 illustrates a typical application for the INT202/201. The LS IN signal directly controls MOSFET Q1. The HS IN signal causes the INT202 to command the INT201 to turn MOSFET Q2 on or off as required.

Local bypassing for the low-side driver is provided by C1. Bootstrap bias for the high-side driver is provided by D1 and C2. Slew rate and effects of parasitic oscillations in the load waveforms are controlled by resistors R1 and R2.

The inputs are designed to be compatible with 5 V CMOS logic levels and should not be connected to V_{DD} . Normal CMOS power supply sequencing should be observed. The order of signal application should be V_{DD} , logic signals, and then HV+. V_{DD} should be supplied from a low impedance voltage source.

The length of time that the high-side can remain on is limited by the size of the bootstrap capacitor. Applications with extremely long high-side on times require special techniques discussed in AN-10.

Maximum frequency of operation is limited by power dissipation due to high-

voltage switching, gate charge, and bias power. Figure 5 indicates the maximum switching frequency as a function of input voltage and gate charge. For higher ambient temperatures, the switching frequency should be derated linearly.

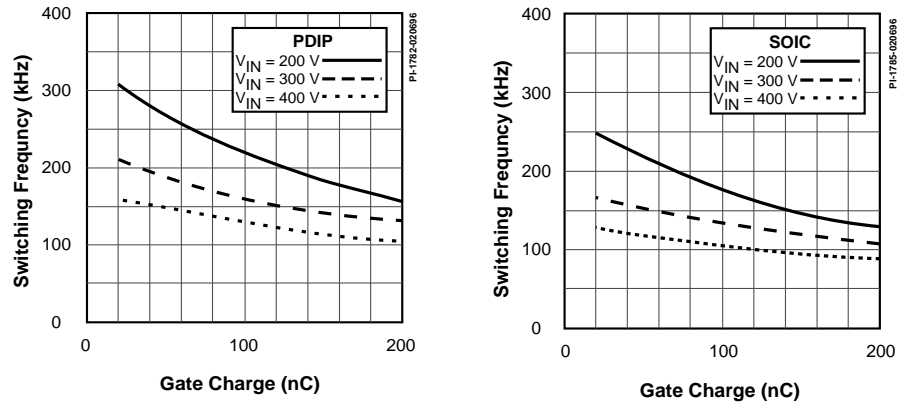

Figure 5. Switching Frequency versus Gate Charge for a) PDIP and b) SOIC.

ABSOLUTE MAXIMUM RATINGS¹

HSD1/HSD2 Voltage (1 Suffix) 600 V	Power Dissipation
(2 Suffix) 800 V	PF Suffix ($T_A = 25^\circ\text{C}$) 1.25 W
HSD1/HSD2 Slew Rate 10 V/ns	($T_A = 70^\circ\text{C}$) 800 mW
V_{DD} Voltage 16.5 V	TF Suffix ($T_A = 25^\circ\text{C}$) 1.04 W
Logic Input Voltage -0.3 V to 5.5 V	($T_A = 70^\circ\text{C}$) 667 mW
LS OUT Voltage -0.3 V to $V_{DD} + 0.3$ V	Thermal Impedance (θ_{JA})
Storage Temperature -65 to 125°C	PF Suffix 100°C/W
Ambient Temperature -40 to 85°C	TF Suffix 120°C/W
Junction Temperature 150°C	
Lead Temperature ⁽²⁾ 260°C	

1. Unless noted, all voltages referenced to COM, $T_A = 25^\circ\text{C}$
2. 1/16" from case for 5 seconds.

Parameter	Symbol	Conditions (Unless Otherwise Specified) $V_{DD} = 15$ V, COM = 0V $T_A = -40$ to 85°C	Min	Typ	Max	Units
LOGIC						
Input Current, High or Low	I_{IH}, I_{IL}	$V_{IH} = 4.0$ V	0	10	150	μA
		$V_{IL} = 1.0$ V	-20	0	20	
Input Voltage High	V_{IH}		4.0			V
Input Voltage Low	V_{IL}				1.0	V
Input Voltage Hysteresis	V_{HY}		0.3	0.7		V
HSD OUTPUTS						
Breakdown Voltage	BV_{DSS}	1 Suffix	600	700		V
		2 Suffix	800	900		
Off-State Output Current	$I_{HSD(OFF)}$	$V_{HSD1}, V_{HSD2} = 500$ V		0.1	15	μA
On-State Output Current	$I_{HSD(ON)}$	$V_{HSD1}, V_{HSD2} = 10$ V	5	25		mA
On-State Pulse Width	$t_{HSD(ON)}$				156	ns
Output Capacitance	C_{OSS}	$V_{HSD1}, V_{HSD2} = 25$ V		10		pF



Parameter	Symbol	Conditions (Unless Otherwise Specified)		Min	Typ	Max	Units
		$V_{DD} = 15\text{ V}$, COM = 0V $T_A = -40\text{ to }85^\circ\text{C}$					
LS OUT							
Output Voltage High	V_{OH}	$I_o = -20\text{ mA}$		$V_{DD} - 1.0$	$V_{DD} - 0.5$		V
Output Voltage Low	V_{OL}	$I_o = 40\text{ mA}$			0.3	1.0	V
Output Short Circuit Current	I_{OS}	See Note 1	$V_o = 0\text{ V}$			-150	mA
			$V_o = V_{DD}$	300			
Turn-on Delay Time	$t_{d(on)}$	See Figure 6			0.6	1.0	μs
Rise Time	t_r	See Figure 6			80	120	ns
Turn-off Delay Time	$t_{d(off)}$	See Figure 6			0.5	1	μs
Fall Time	t_f	See Figure 6			50	100	ns
SYSTEM RESPONSE							
Matching (Low On to High On)	Mt_{P+}	See Figure 7			0.3	1	μs
Matching (Low Off to High Off)	Mt_{P-}	See Figure 7			0.3	1	μs
UNDERVOLTAGE LOCKOUT							
Input UV Trip-off Voltage	$V_{DD(UV)}$			8.5	9.0	10	V
Input UV Hysteresis				175	350		mV
SUPPLY							
Supply Current	I_{DD}	See Note 2			1.5	3.0	mA
Supply Voltage	V_{DD}			10		16	V

NOTES:

1. Applying a short circuit to the LS OUT pin for more than 500 μs will exceed the thermal rating of the package, resulting in destruction of the part.
2. V_{DD} supply must have less than 30 Ω output impedance.

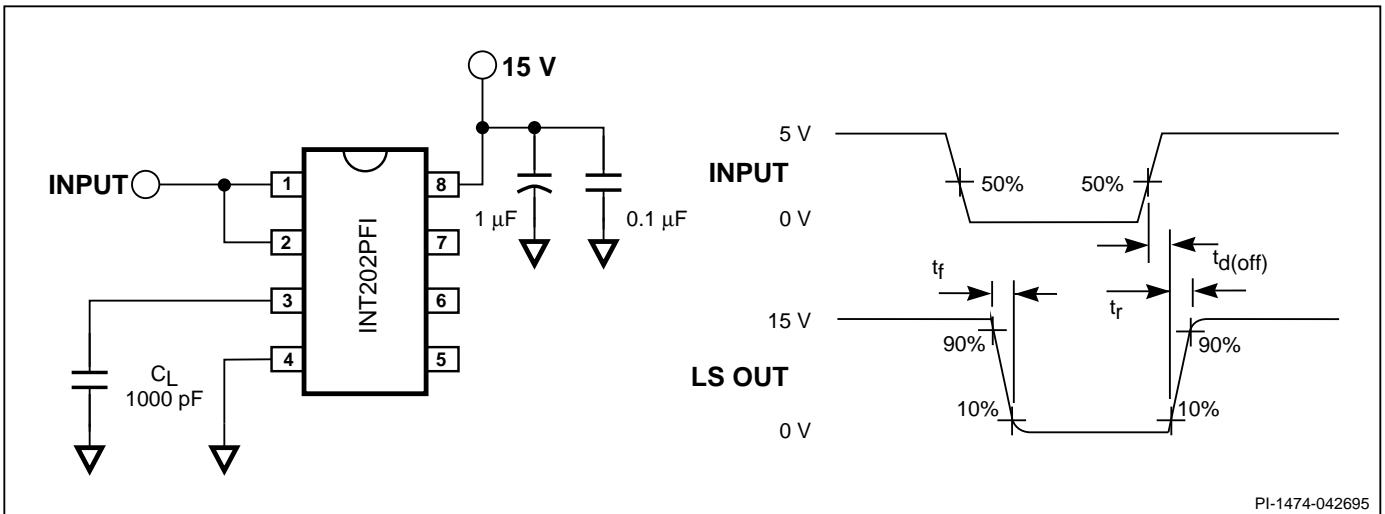

Figure 6. Switching Time Test Circuit.

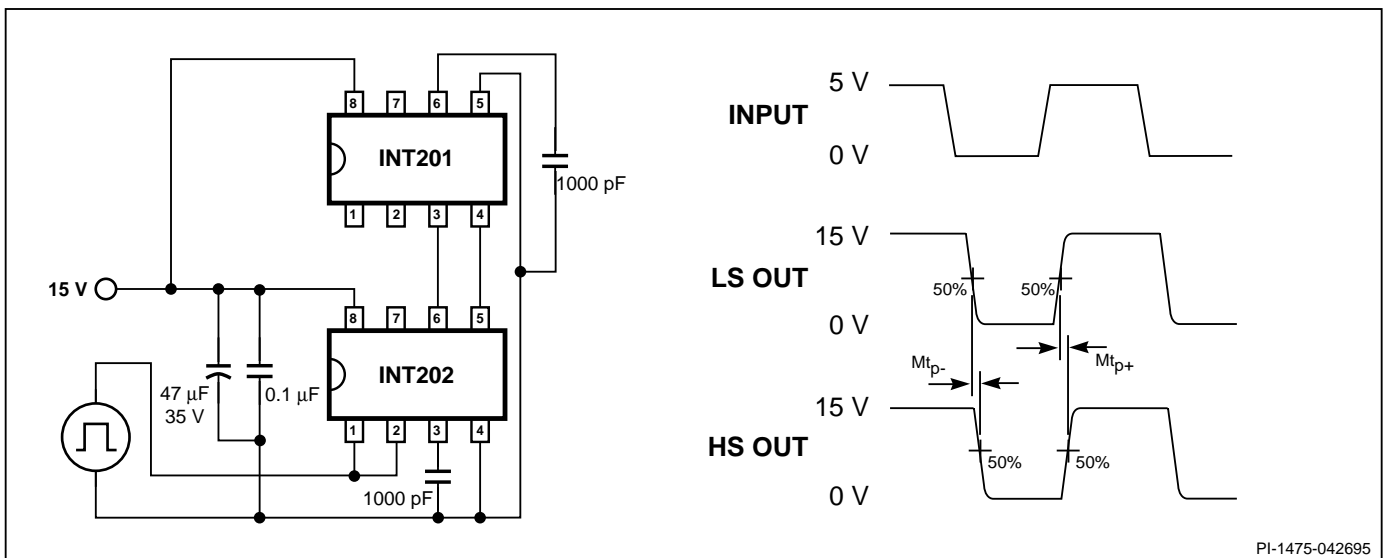
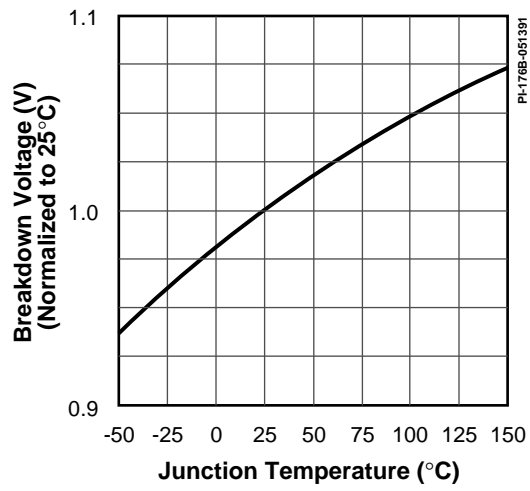
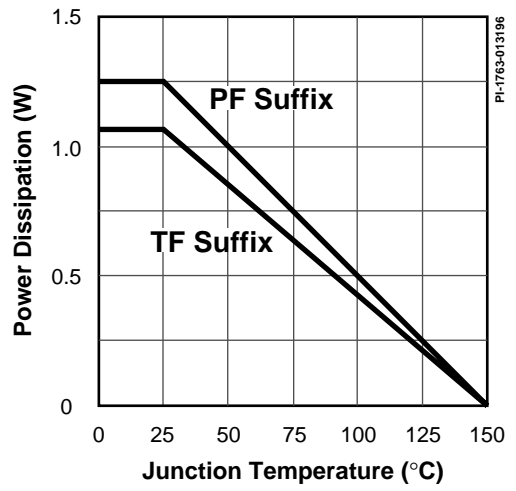

Figure 7. Matching Test Circuit.

BREAKDOWN vs. TEMPERATURE



PACKAGE POWER DERATING



P08A

Plastic DIP-8

Dim.	inches	mm
A	.395 MAX	10.03 MAX
B	.090-.110	2.29-2.79
C	.015-.021	0.38-0.53
D	.040 TYP	1.02 TYP
E	.015-.030	0.38-0.76
F	.125 MIN	3.18 MIN
G	.015 MIN	0.38 MIN
H	.125-.135	3.18-3.43
J	.300-.320	7.62-8.13
K	.245-.255	6.22-6.48
L	.009-.015	0.23-0.38

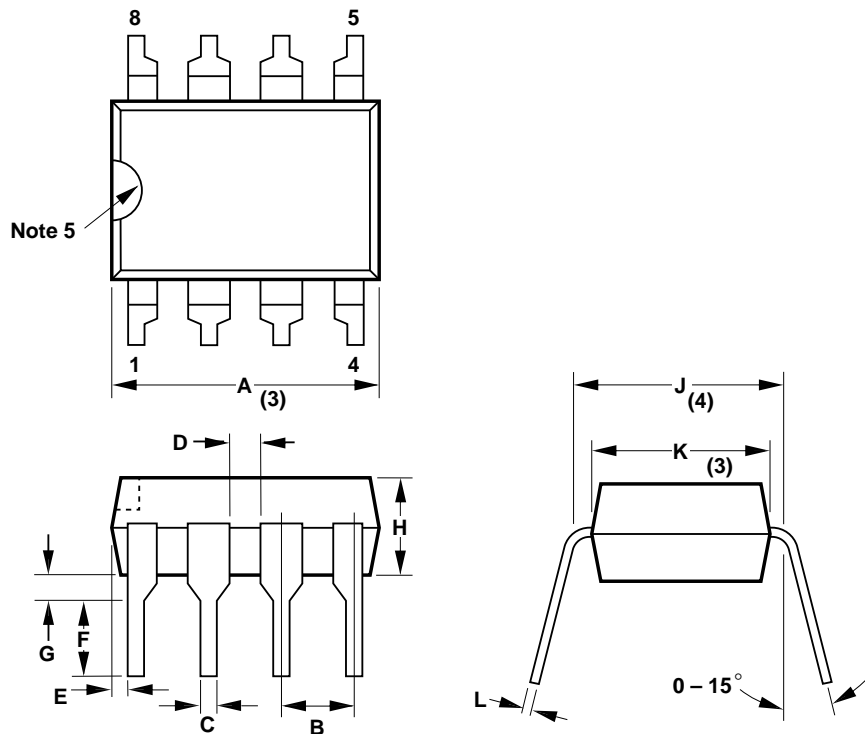

Notes:

1. Package dimensions conform to JEDEC specification MS-001-AB for standard dual in-line (DIP) package .300 inch row spacing (PLASTIC) 8 leads (issue B, 7/85).
2. Controlling dimensions: inches.
3. Dimensions are for the molded body and do not include mold flash or other protrusions. Mold flash or protrusions shall not exceed .010 inch (.25 mm) on any side.
4. These dimensions measured with the leads constrained to be perpendicular to package bottom.
5. Pin 1 orientation identified by end notch or dot adjacent to Pin 1.

PI-1842-050196

T08A

Plastic SO-8

DIM	inches	mm
A	0.189-0.197	4.80-5.00
B	0.050 TYP	1.27 TYP
C	0.014-0.019	0.35-0.49
D	0.012 TYP	0.31 TYP
E	0.053-0.069	1.35-1.75
F	0.004-0.010	0.10-0.25
G	0.228-0.244	5.80-6.20
H	0.007-0.010	0.19-0.25
J	0.021-0.045	0.51-1.14
K	0.150-0.157	3.80-4.00

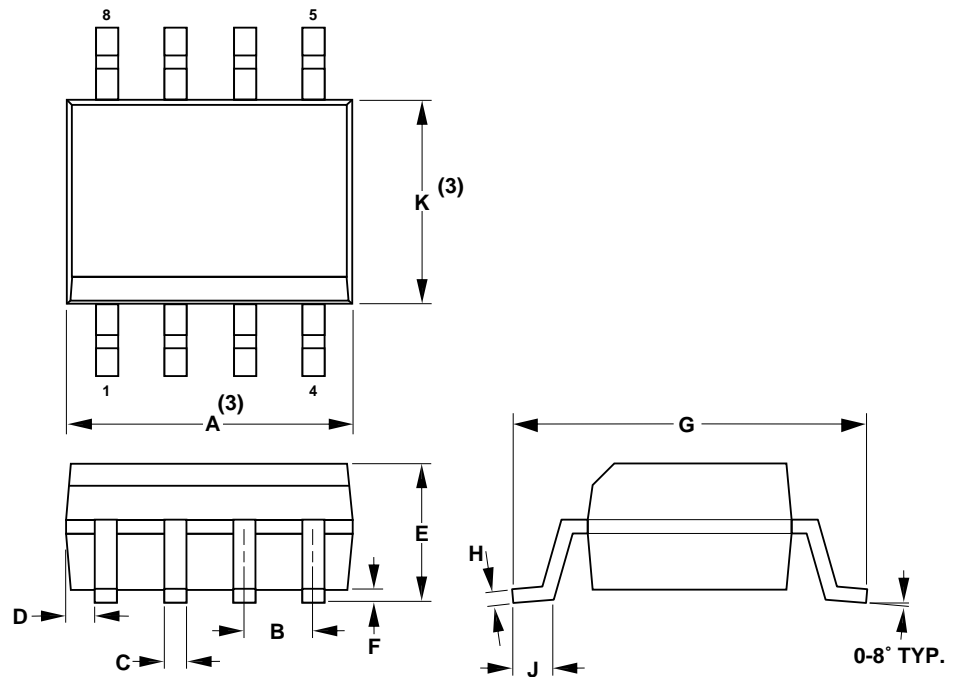

Notes:

1. Package dimensions conform to JEDEC specification MS-012-AA for standard small outline (SO) package, 8 leads, 3.75 mm (.150 inch) body width (issue A, June 1985).
2. Controlling dimensions are in mm.
3. Dimensions are for the molded body and do not include mold flash or protrusions. Mold flash or protrusions shall not exceed .15 mm (.006 inch) on any side.
4. Pin 1 side identified edge by chamfer on top of the package body or indent on Pin 1 end.

PI-1845-050196



Notes



Notes

Power Integrations reserves the right to make changes to its products at any time to improve reliability or manufacturability. Power Integrations does not assume any liability arising from the use of any device or circuit described herein, nor does it convey any license under its patent rights or the rights of others.

PI Logo and **TOPSwitch** are registered trademarks of Power Integrations, Inc.
©Copyright 1994, Power Integrations, Inc. 477 N. Mathilda Avenue, Sunnyvale, CA 94086

WORLD HEADQUARTERS

Power Integrations, Inc.
477 N. Mathilda Avenue
Sunnyvale, CA 94086
USA
Main: 408•523•9200
Customer Service:
Phone: 408•523•9265
Fax: 408•523•9365

AMERICAS

For Your Nearest Sales/Rep Office
Please Contact Customer Service
Phone: 408•523•9265
Fax: 408•523•9365

EUROPE & AFRICA

Power Integrations (Europe) Ltd.
Mountbatten House
Fairacres
Windsor SL4 4LE
United Kingdom
Phone: 44•(0)•1753•622•208
Fax: 44•(0)•1753•622•209

JAPAN

Power Integrations, K.K.
Keihin-Tatemono 1st Bldg.
12-20 Shin-Yokohoma 2-Chome, Kohoku-ku
Yokohama-shi, Kanagawa 222 Japan
Phone: 81•(0)•45•471•1021
Fax: 81•(0)•45•471•3717

ASIA & OCEANIA

For Your Nearest Sales/Rep Office
Please Contact Customer Service
Phone: 408•523•9265
Fax: 408•523•9365

APPLICATIONS HOTLINE

World Wide 408•523•9260

APPLICATIONS FAX

Americas 408•523•9361
Europe/Africa
44•(0)•1753•622•209
Japan 81•(0)•45•471•3717
Asia/Oceania 408•523•9364





LittleDiode supplies new, hard to find or obsolete electronic components and semiconductors all over the world.

With over two million different components listed you are sure to find the part you need.

Feel free to visit us today at our online store:

LittleDiode.com

Looking forward to providing you with the best possible service.