

IR04H420

HIGH VOLTAGE HALF-BRIDGE

Product Summary

$V_{IN} \text{ (max)}$	500V
$t_{on/off}$	130 ns
t_{rr}	270 ns
$R_{DS(on)}$	3.0Ω
$P_D \text{ (} T_A = 25 \text{ }^\circ\text{C)}$	2.0W

Features

- Output Power MOSFETs in half-bridge configuration
- 500V Rated Breakdown Voltage
- High side gate drive designed for bootstrap operation
- Matched propagation delay for both channels
- Independent high and low side output channels
- Undervoltage lockout
- 5V Schmitt-triggered input logic
- Half-Bridge output in phase with IN
- Cross conduction prevention logic
- Internally set dead time
- Shut down input turns off both channels

Description

The IR04H420 is a high voltage, high speed half bridge. Proprietary HVIC and latch immune CMOS technologies, along with the HEXFET® power MOSFET technology, enable ruggedized single package construction. The logic inputs are compatible with standard CMOS or LSTTL outputs. The front end features an independent high and low side driver in phase with the logic compatible input signals. The output features two HEXFETs in a half-bridge configuration with a high pulse current buffer stage designed for minimum cross-conduction in the half-bridge. Propagation delays for the high and low side power MOSFETs are matched to simplify use. The device can operate up to 500 volts.

Package

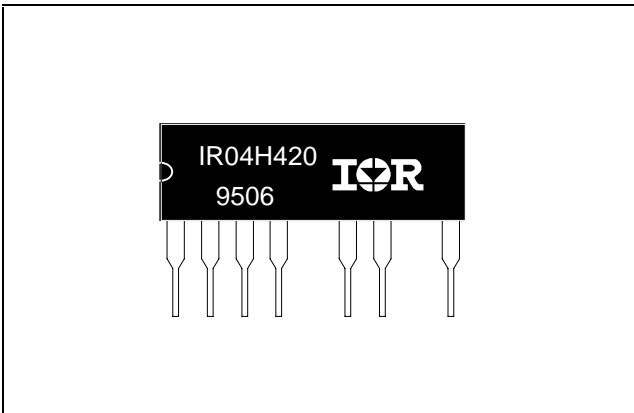

Typical Connection

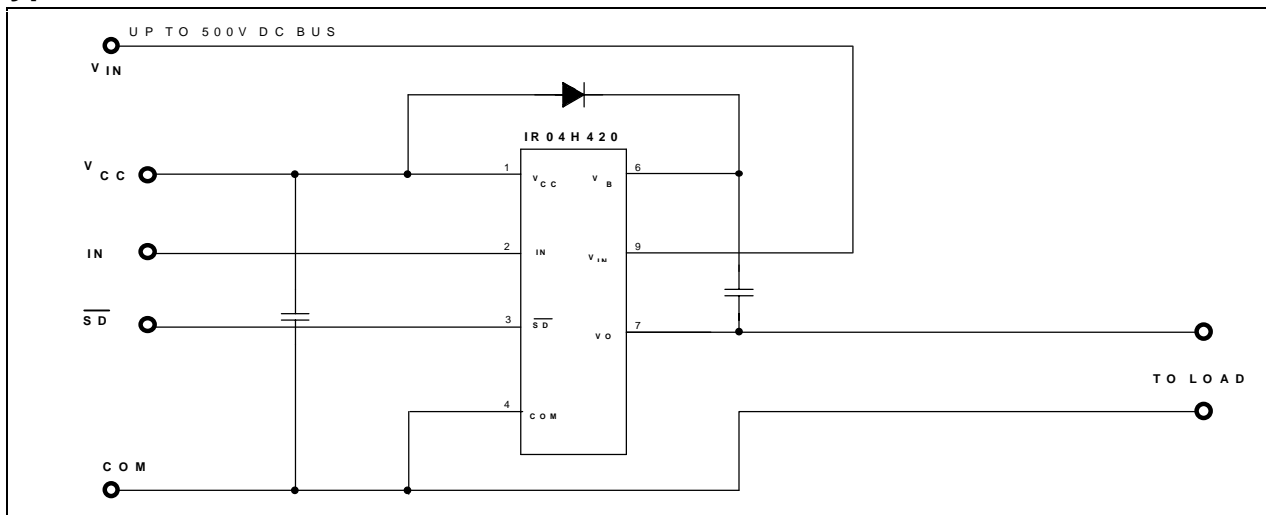

Absolute Maximum Ratings

Absolute Maximum Ratings indicate sustained limits beyond which damage to the device may occur. All voltage parameters are absolute voltages referenced to COM, all currents are defined positive into any lead. The Thermal Resistance and Power Dissipation ratings are measured under board mounted and still air conditions.

Symbol	Parameter Definition	Min.	Max.	Units
V _{IN}	High Voltage Supply	-0.3	500	V
V _B	High Side Floating Supply Absolute Voltage	-0.3	525	
V _O	Half-Bridge Output Voltage	-0.3	V _{IN} + 0.3	
V _{IH}	Logic Input Voltage (IN & SD)	-0.3	V _{CC} + 0.3	
V _{CC}	Low Side and Logic Fixed Supply Voltage	-0.3	25	
dv/dt	Peak Diode Recovery dv/dt	---	3.5	V/ns
P _D	Package Power Dissipation @ T _A ≤ +25°C	---	2.00	W
R _{θJA}	Thermal Resistance, Junction to Ambient	---	60	°C/W
T _J	Junction Temperature	-55	150	°C
T _S	Storage Temperature	-55	150	
T _L	Lead Temperature (Soldering, 10 seconds)	---	300	

Recommended Operating Conditions

The Input/Output logic timing diagram is shown in Figure 1. For proper operation the device should be used within the recommended conditions.

Symbol	Parameter Definition	Min.	Max.	Units	
V _B	High Side Floating Supply Absolute Voltage	VO + 10	VO + 20	V	
V _{IN}	High Voltage Supply	---	500		
V _O	Half-Bridge Output Voltage	(note 1)	500		
V _{CC}	Low Side and Logic Fixed Supply Voltage	10	20		
V _{IH}	Logic Input Voltage (IN & SD)	0	V _{CC}		
I _D	Continuous Drain Current	(T _A = 25°C)	---	0.7	A
		(T _A = 85°C)	---	0.5	
T _A	Ambient Temperature	-40	125	°C	

Note 1: Logic operational for VO of -5 to 500 V. Logic state held for VO of -5 to -V_B.

Dynamic Electrical Characteristics

V_{BIAS} (V_{CC} , V_B) = 15V and $T_A = 25^\circ\text{C}$ unless otherwise specified. Switching time waveform definitions are shown in figure 2.

Symbol	Parameter Definition	$T_A = 25^\circ\text{C}$			Units	Test Conditions
		Min.	Typ.	Max.		
t_{on}	Turn-On Propagation Delay (see note 2)	---	600	720	ns	$V_S = 0\text{ V}$
t_{off}	Turn-Off Propagation Delay (see note 2)	---	90	200		$V_S = 500\text{ V}$
t_r	Turn-On Rise Time (see note 2)	---	80	120		
t_f	Turn-Off Fall Time (see note 2)	---	40	70		
MT	Delay Matching, HS & LS Turn-On/Off	---	30	---		
DT	Deadtime, LS Turn-Off to HS Turn-On & HS Turn-On to LS Turn-Off	---	500	750		
t_{rr}	Reverse Recovery Time (MOSFET Body Diode)	---	260	---	μC	$I_F = 0.7\text{ A}$
Q_{rr}	Reverse Recovery Charge (MOSFET Body Diode)	---	0.7	---		$di/dt = 100\text{A}/\mu\text{s}$

Note 2: Switching times as specified and illustrated in figure 2 are referenced to the MOSFET gate input voltage. This is shown as HO in figure 2.

Static Electrical Characteristics

V_{BIAS} (V_{CC} , V_B) = 15V and $T_A = 25^\circ\text{C}$ unless otherwise specified. The Input voltage and current levels are referenced to COM.

Symbol	Parameter Definition	$T_A = 25^\circ\text{C}$			Units	Test Conditions
		Min.	Typ.	Max.		
Supply Characteristics						
V_{CCUV+}	V_{CC} Supply Undervoltage Positive Going Threshold	8.8	9.3	9.8	V	
V_{CCUV-}	V_{CC} Supply Undervoltage Negative Going Threshold	7.5	8.2	8.6		
I_{QCC}	Quiescent V_{CC} Supply Current	---	140	240	μA	
I_{QBS}	Quiescent V_{BS} Supply Current	---	20	50		
I_{OS}	Offset Supply Leakage Current	---	---	50		$V_B = V_S = 500\text{V}$
Input Characteristics						
V_{IH}	Logic "1" Input Voltage	2.7	---	---	V	$V_{CC} = 10\text{V to } 20\text{V}$
V_{IL}	Logic "0" Input Voltage	---	---	0.8		
$V_{SD,TH+}$	SD Input Positive Going Threshold	2.7	---	---		
$V_{SD,TH-}$	SD Input Negative Going Threshold	---	---	0.8		
I_{IN+}	Logic "1" Input Bias Current	---	20	40	μA	
I_{IN-}	Logic "0" Input Bias Current	---	---	1.0	μA	
Output Characteristics						
$R_{DS(on)}$	Static Drain-to-Source On-Resistance	---	3.0	---	Ω	$I_D = 700\text{mA}$
V_{SD}	Diode Forward Voltage	---	0.8	---	V	$T_i = 150^\circ\text{C}$

Functional Block Diagram

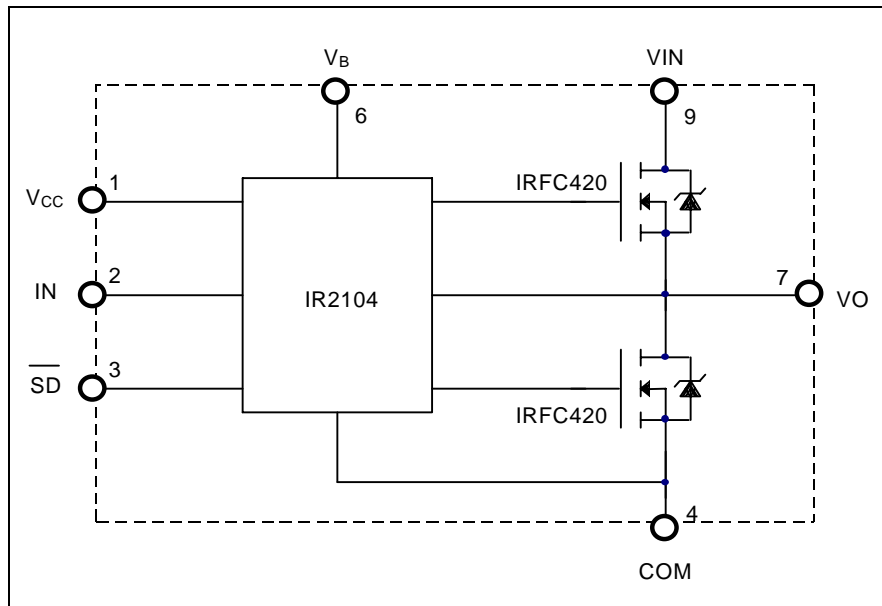

Lead Definitions

Symbol	Lead Description
V_{CC}	Logic and internal gate drive supply voltage.
IN	Logic input for high and low side gate driver outputs (HO and LO), in phase with HO
\overline{SD}	Logic input for shutdown
V_B	High side gate drive floating supply. For bootstrap operation a high voltage fast recovery diode is needed to feed from V_{CC} to V_B .
V_{IN}	High voltage supply.
VO	Half-Bridge output.
COM	Logic and low side of Half-Bridge return.

Lead Assignments

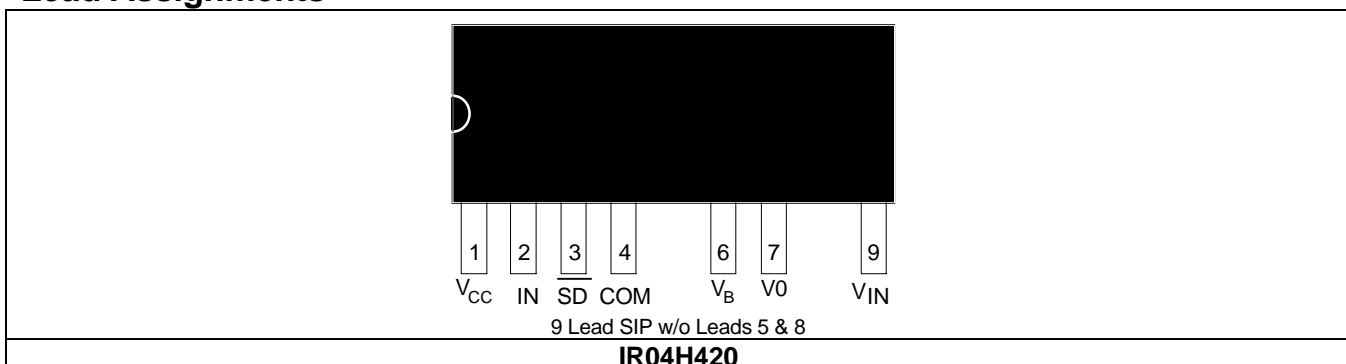



IR04H420

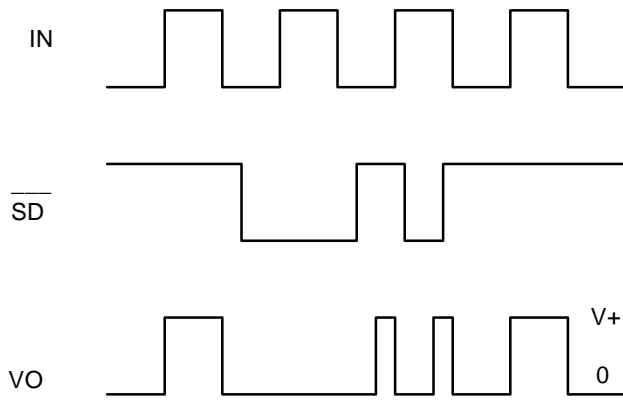

Figure 1. Input/Output Timing Diagram

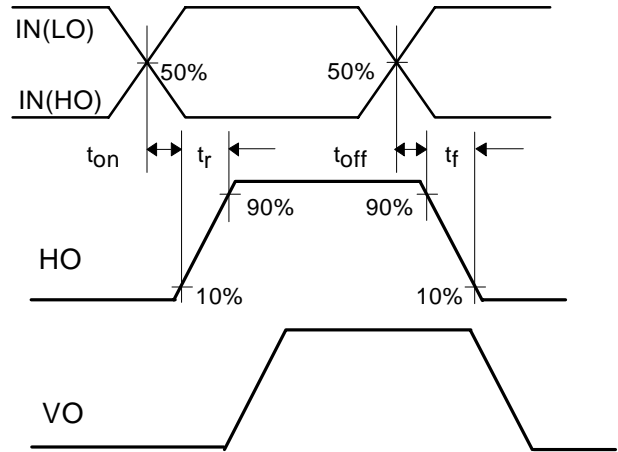

Figure 2. Switching Time Waveform Definitions

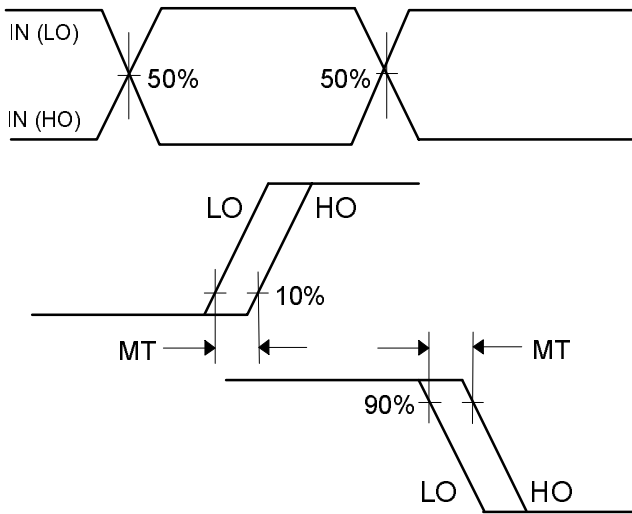

Figure 3. Delay Matching Waveform Definitions

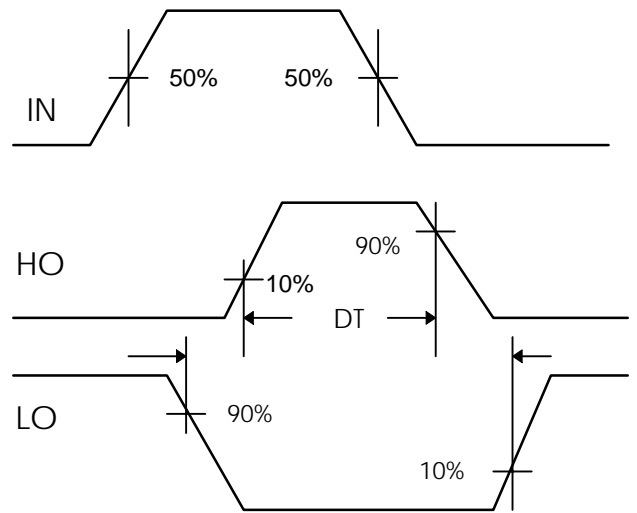

Figure 4. Deadtime Waveform Definitions



LittleDiode supplies new, hard to find or obsolete electronic components and semiconductors all over the world.

With over two million different components listed you are sure to find the part you need.

Feel free to visit us today at our online store:

LittleDiode.com

Looking forward to providing you with the best possible service.