

## 7.5A ULTRA LOW DROPOUT POSITIVE ADJUSTABLE REGULATOR

### FEATURES

- 0.5V Dropout at 7.5A (Equivalent of 67mΩ)
- Fast Transient Response
- 1% Voltage Reference Initial Accuracy
- Built-In Thermal Shutdown

### APPLICATIONS

- 3.3V to 2.7V Intel I740 Chip Set

### DESCRIPTION

The IRU1175 is a 7.5A regulator with extremely low dropout voltage using a proprietary bipolar process that achieves comparable equivalent on resistance to that of discrete MOSFETs. This product is specifically designed to provide well regulated supply for applications requiring very low dropout such as 2.8V from 3.3V ATX power supplies where the same efficiency as the switcher can be achieved without the cost and complexity associated with switching regulators. One such application is the new graphic chip sets that require 2.7V supply such as the Intel I740 chip set.

### TYPICAL APPLICATION

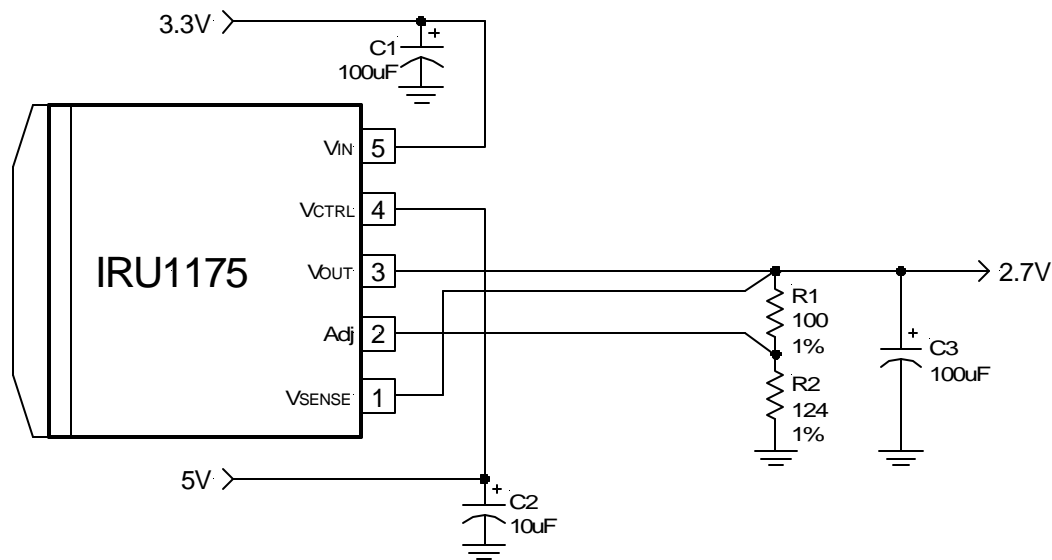

Figure 1 - Typical application of IRU1175.

### PACKAGE ORDER INFORMATION

T <sub>J</sub> (°C)	5-PIN PLASTIC TO-263 (M)	5-PIN PLASTIC Ultra Thin-Pak™ (P)
0 To 125	IRU1175CM	IRU1175CP

**ABSOLUTE MAXIMUM RATINGS**

Input Voltage ( $V_{IN}$ ) .....	6V
Control Input Voltage ( $V_{CTRL}$ ) .....	14V
Power Dissipation .....	Internally Limited
Storage Temperature Range .....	-65°C To 150°C
Operating Junction Temperature Range .....	0°C To 150°C

**PACKAGE INFORMATION**

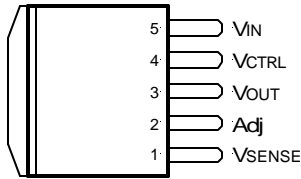
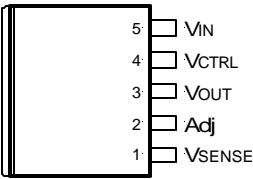
5-PIN PLASTIC TO-263 (M)	5-PIN PLASTIC ULTRA THIN-PAK™ (P)
 <p><math>\theta_{JA}=35^{\circ}\text{C/W}</math> for 0.5" square pad</p>	 <p><math>\theta_{JA}=35^{\circ}\text{C/W}</math> for 0.5" square pad</p>

**ELECTRICAL SPECIFICATIONS**

Unless otherwise specified, these specifications apply over  $C_{IN}=1\mu\text{F}$ ,  $C_{OUT}=10\mu\text{F}$ , and  $T_J=0$  to  $125^{\circ}\text{C}$ . Typical values refer to  $T_J=25^{\circ}\text{C}$ .  $V_{OUT}=V_{SENSE}$ .

PARAMETER	SYM	TEST CONDITION	MIN	TYP	MAX	UNITS
Reference Voltage	$V_{REF}$	$V_{CTRL}=2.75$ , $V_{IN}=2\text{V}$ , $I_o=10\text{mA}$ , $T_J=25^{\circ}\text{C}$ , $V_{ADJ}=0\text{V}$ $V_{CTRL}=2.7$ to $12\text{V}$ , $V_{IN}=2.05\text{V}$ to $5.5\text{V}$ , $I_o=10\text{mA}$ to $7.5\text{A}$ , $V_{ADJ}=0\text{V}$	1.225	1.250	1.275	V
Line Regulation		$V_{CTRL}=2.5\text{V}$ to $7\text{V}$ , $V_{IN}=1.75\text{V}$ to $5.5\text{V}$ , $I_o=10\text{mA}$ , $V_{ADJ}=0\text{V}$		0.5	3	mV
Load Regulation (Note 1)		$V_{CTRL}=2.75\text{V}$ , $V_{IN}=2.1\text{V}$ , $I_o=10\text{mA}$ to $7.5\text{A}$ , $V_{ADJ}=0\text{V}$		2	6	mV
Dropout Voltage (Note 2) ( $V_{CTRL} - V_{OUT}$ )		$V_{ADJ}=0\text{V}$ for all conditions below: $V_{IN}=2.05\text{V}$ , $I_o=1.5\text{A}$ $V_{IN}=2.05\text{V}$ , $I_o=3\text{A}$ $V_{IN}=2.05\text{V}$ , $I_o=5\text{A}$ $V_{IN}=2.05\text{V}$ , $I_o=7.5\text{A}$		0.95 1.00 1.05 1.15	1.30	V
Dropout Voltage (Note 2) ( $V_{IN} - V_{OUT}$ )		$V_{ADJ}=0\text{V}$ for all conditions below: $V_{CTRL}=2.75\text{V}$ , $I_o=1.5\text{A}$ $V_{CTRL}=2.75\text{V}$ , $I_o=3\text{A}$ $V_{CTRL}=2.75\text{V}$ , $I_o=3\text{A}$ $V_{CTRL}=2.75\text{V}$ , $I_o=7.5\text{A}$		0.100 0.200 0.330 0.500	0.130 0.260 0.430 0.650	V
Current Limit		$V_{CTRL}=2.75\text{V}$ , $V_{IN}=2.05\text{V}$ , $\Delta V_o=100\text{mV}$ , $V_{ADJ}=0\text{V}$	7.7	9		A
Minimum Load Current (Note 3)		$V_{CTRL}=5\text{V}$ , $V_{IN}=3.3\text{V}$ , $V_{ADJ}=0\text{V}$		5	10	mA
Thermal Regulation		30ms Pulse		0.01	0.02	%/W
Ripple Rejection		$V_{CTRL}=5\text{V}$ , $V_{IN}=5\text{V}$ , $I_o=3\text{A}$ , $V_{ADJ}=0\text{V}$ , $T_J=25^{\circ}\text{C}$ , $V_{RIPPLE}=1\text{V}_{PP}$ at 120Hz	60	70		dB

PARAMETER	SYM	TEST CONDITION	MIN	TYP	MAX	UNITS
Control Pin Current		$V_{ADJ}=0V$ for all below conditions: $V_{CTRL}=2.75V, V_{IN}=2.05V, I_o=1.5A$ $V_{CTRL}=2.75V, V_{IN}=2.05V, I_o=3A$ $V_{CTRL}=2.75V, V_{IN}=2.05V, I_o=5A$ $V_{CTRL}=2.75V, V_{IN}=2.05V, I_o=7.5A$		15 30 50 70		mA
Adjust Pin Current	$I_{ADJ}$	$V_{CTRL}=2.75V, V_{IN}=2.05V, V_{ADJ}=0V$		50	120	$\mu A$

**Note 1:** Low duty cycle pulse testing with Kelvin connections are required in order to maintain accurate data.

**Note 2:** Dropout voltage is defined as the minimum differential between  $V_{IN}$  and  $V_{OUT}$  required to maintain regulation at  $V_{OUT}$ . It is measured when the output voltage drops 1% below its nominal value.

**Note 3:** Minimum load current is defined as the minimum current required at the output in order for the output voltage to maintain regulation. Typically the resistor dividers are selected such that it automatically maintains this current.

## PIN DESCRIPTIONS

PIN #	PIN SYMBOL	PIN DESCRIPTION
1	$V_{SENSE}$	This pin is the positive side of the reference which allows remote load sensing to achieve excellent load regulation.
2	Adj	A resistor divider from this pin to the $V_{OUT}$ pin and ground sets the output voltage.
3	$V_{OUT}$	The output of the regulator. A minimum of $10\mu F$ capacitor must be connected from this pin to ground to insure stability.
4	$V_{CTRL}$	This pin is the supply pin for the internal control circuitry as well as the base drive for the pass transistor. This pin must always be higher than the $V_{OUT}$ pin in order for the device to regulate. (See specifications)
5	$V_{IN}$	The input pin of the regulator. Typically a large storage capacitor is connected from this pin to ground to insure that the input voltage does not sag below the minimum drop out voltage during the load transient response. This pin must always be higher than $V_{OUT}$ in order for the device to regulate. (See specifications)

**BLOCK DIAGRAM**

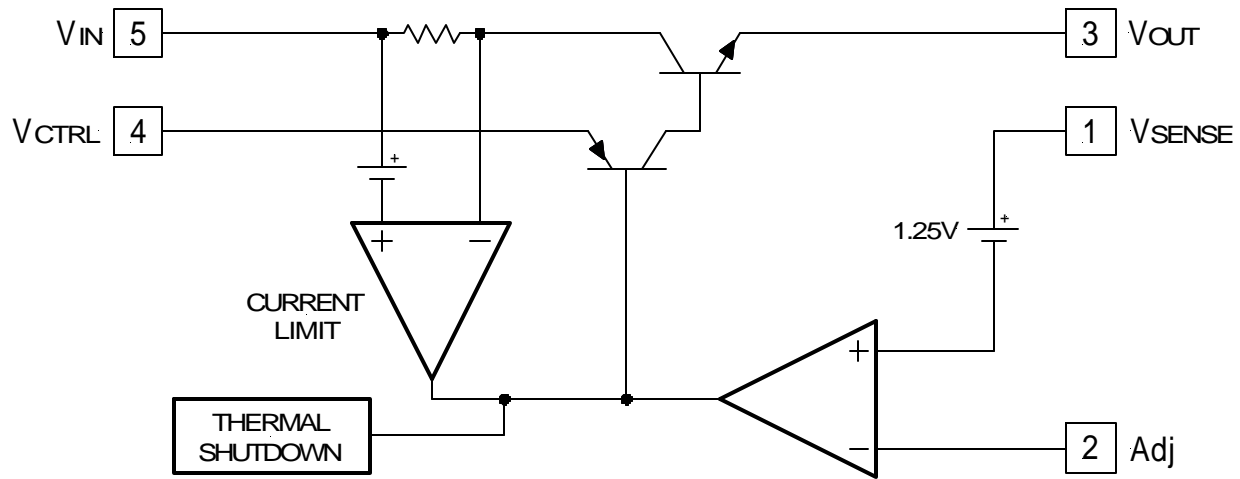

Figure 2 - Simplified block diagram of the IRU1175.

**APPLICATION INFORMATION**

**Introduction**

The IRU1175 adjustable regulator is a five-terminal device designed specifically to provide extremely low drop-out voltages comparable to the PNP type without the disadvantage of the extra power dissipation due to the base current associated with PNP regulators. This is done by bringing out the control pin of the regulator that provides the base current to the power NPN and connecting it to a voltage that is greater than the voltage present at the VIN pin. This flexibility makes the IRU1175 ideal for applications where dual inputs are available such as a computer mother board with an ATX style power supply that provides 5V and 3.3V to the board. One such application is the new graphic chip sets that require anywhere from 2.4V to 2.7V supply such as the Intel I740 chip set. The IRU1175 can easily be programmed with the addition of two external resistors to any voltages within the range of 1.25 to 5.5V. Another major requirement of these graphic chips is the need to switch the load current from zero to several amps in tens of nano-seconds at the processor pins, which translates to an approximately 300 to 500ns of current step at the regulator. In addition, the output voltage tolerances are also extremely tight and they include the transient response as part of the specification.

The IRU1175 is specifically designed to meet the fast current transient needs as well as providing an accurate initial voltage, reducing the overall system cost with the

need for fewer number of output capacitors. Another feature of the device is its true remote sensing capability which allows accurate voltage setting at the load rather than at the device.

**Output Voltage Setting**

The IRU1175 can be programmed to any voltages in the range of 1.25V to 5.5V with the addition of R1 and R2 external resistors according to the following formula:

$$V_{OUT} = V_{REF} \times \left(1 + \frac{R_2}{R_1}\right) + I_{ADJ} \times R_2$$

Where:

VREF = 1.25V Typically

IADJ = 50µA Typically

R1 & R2 as shown in Figure 3:

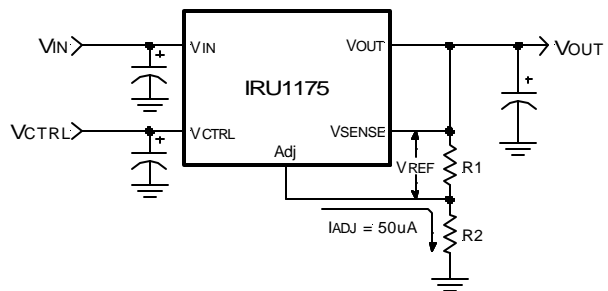

Figure 3 - Typical application of the IRU1175 for programming the output voltage.

The IRU1175 keeps a constant 1.25V between the  $V_{SENSE}$  pin and the  $V_{ADJ}$  pin. By placing a resistor R1 across these two pins and connecting the  $V_{SENSE}$  and  $V_{OUT}$  pin together, a constant current flows through R1, adding to the  $I_{ADJ}$  current and into the R2 resistor producing a voltage equal to the  $(1.25/R1) \times R2 + I_{ADJ} \times R2$ . This voltage is then added to the 1.25V to set the output voltage. This is summarized in the above equation. Since the minimum load current requirement of the IRU1175 is 10mA, R1 is typically selected to be a 121Ω resistor so that it automatically satisfies this condition. Notice that since the  $I_{ADJ}$  is typically in the range of 50μA it adds a small error to the output voltage and should be considered when very precise output voltage setting is required.

**Load Regulation**

Since the IRU1175 has separate pins for the output ( $V_{OUT}$ ) and the sense ( $V_{SENSE}$ ), it is ideal for providing true remote sensing of the output voltage at the load. This means that the voltage drops due to parasitic resistance such as PCB traces between the regulator and the load are compensated for using remote sensing. Figure 4 shows a typical application of the IRU1175 with remote sensing.

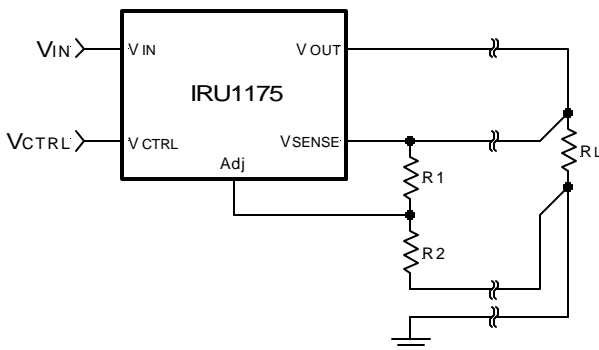

Figure 4 - Schematic showing connection for best load regulation.

**Stability**

The IRU1175 requires the use of an output capacitor as part of the frequency compensation in order to make the regulator stable. Typical designs for the microprocessor applications use standard electrolytic capacitors with typical ESR in the range of 50 to 100mΩ and an output capacitance of 500 to 1000μF. Fortunately as the capacitance increases, the ESR decreases resulting in a fixed RC time constant. The IRU1175 takes advantage of this phenomena in making the overall regulator loop stable.

For most applications a minimum of 100μF aluminum electrolytic capacitor such as Sanyo, MVGX series, Panasonic FA series as well as the Nichicon PL series insures both stability and good transient response.

**Thermal Design**

The IRU1175 incorporates an internal thermal shutdown that protects the device when the junction temperature exceeds the allowable maximum junction temperature. Although this device can operate with junction temperatures in the range of 150°C, it is recommended that the selected heat sink be chosen such that during maximum continuous load operation the junction temperature is kept below this number. The example below shows the steps in selecting the proper surface mount package.

Assuming, the following conditions:

$$\begin{aligned} V_{OUT} &= 2.7V \\ V_{IN} &= 3.3V \\ V_{CTRL} &= 5V \\ I_{OUT} &= 2A \text{ (DC Avg)} \end{aligned}$$

Calculate the maximum power dissipation using the following equation:

$$P_D = I_{OUT} \times (V_{IN} - V_{OUT}) + \left(\frac{I_{OUT}}{60}\right) \times (V_{CTRL} - V_{OUT})$$

$$P_D = 2 \times (3.3 - 2.7) + \left(\frac{2}{60}\right) \times (5 - 2.7) = 1.28W$$

Using table below select the proper package and the amount of copper board needed.

Pkg	Copper Area	$\theta_{JA}(\text{°C/W})$	Max Pd ( $T_A=25\text{°C}$ )	Max Pd ( $T_A=45\text{°C}$ )
TO-263	1.4"x1.4"	25	4.4W	3.6W
TO-263	1.0"x1.0"	30	3.7W	3.0W
TO-263	0.7"x0.7"	35	3.1W	2.6W
TO-263	Pad Size	45	2.4W	2.0W

**Note:** Above table is based on the maximum junction temperature of 135°C.

(M) TO-263 Package  
 5-Pin

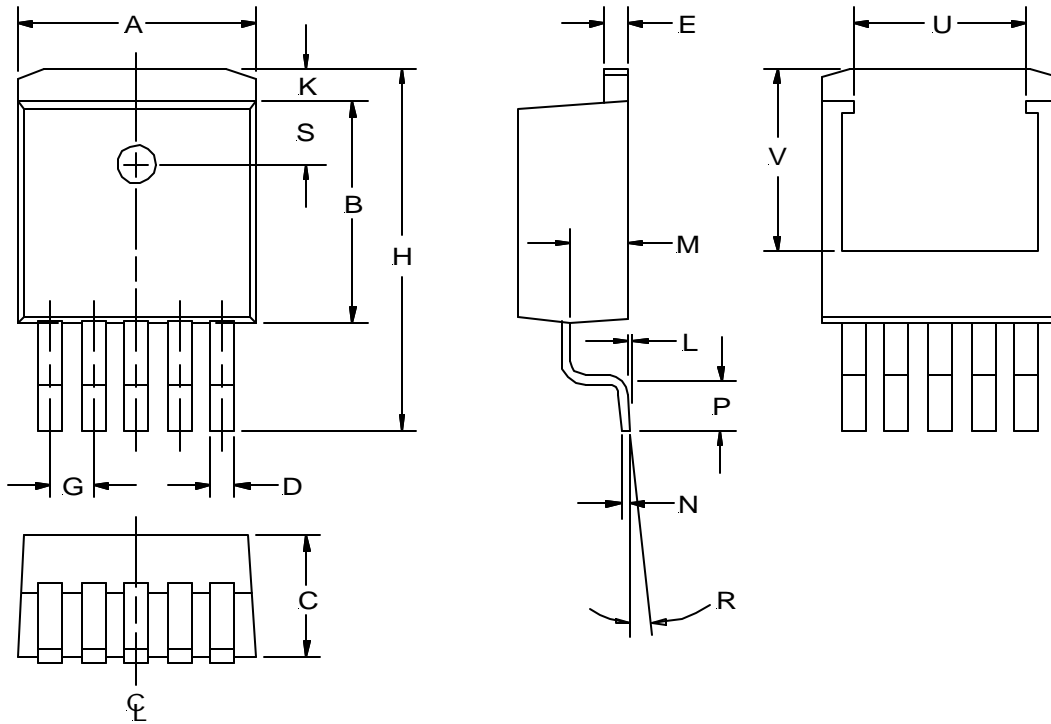

SYMBOL	MIN	MAX
A	10.05	10.668
B	8.28	9.169
C	4.31	4.597
D	0.66	0.91
E	1.14	1.40
G	1.575	1.829
H	14.605	15.875
K	1.143	1.68
L	0.00	0.305
M	2.49	2.74
N	0.33	0.58
P	2.286	2.794
R	0°	8°
S	1.143	2.67
U	6.50 REF	
V	7.75 REF	

NOTE: ALL MEASUREMENTS  
 ARE IN MILLIMETERS.

**(P) Ultra Thin-Pak™  
 5-Pin**

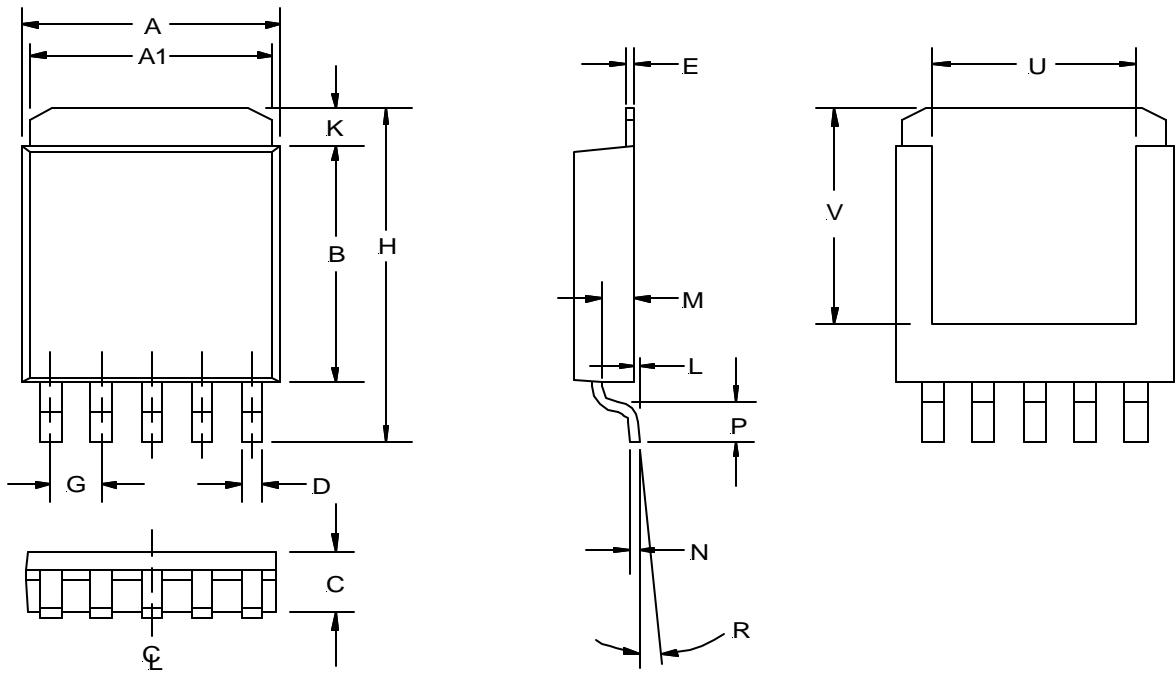

SYMBOL	MIN	MAX
A	9.27	9.52
A1	8.89	9.14
B	7.87	8.13
C	1.78	2.03
D	0.63	0.79
E	0.25 NOM	
G	1.72	
H	10.41	10.67
K	0.76	1.27
L	0.03	0.13
M	0.89	1.14
N	0.25	
P	0.79	1.04
R	3°	6°
U	5.59 NOM	
V	7.49 NOM	

NOTE: ALL MEASUREMENTS  
 ARE IN MILLIMETERS.

**PACKAGE SHIPMENT METHOD**

PKG DESIG	PACKAGE DESCRIPTION	PIN COUNT	PARTS PER TUBE	PARTS PER REEL	T & R Orientation
M	TO-263	5	50	750	Fig A
P	Ultra Thin-Pak™	5	75	2500	Fig B

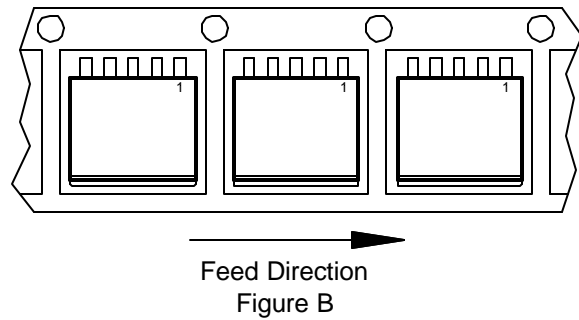
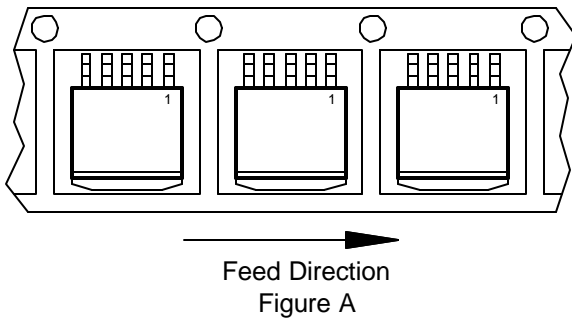



LittleDiode supplies new, hard to find or obsolete electronic components and semiconductors all over the world.

With over two million different components listed you are sure to find the part you need.

Feel free to visit us today at our online store:

[LittleDiode.com](http://LittleDiode.com)

Looking forward to providing you with the best possible service.