

### APPLICATIONS

Differential data transmission lines protection :

- RS-232
- RS-423
- RS-422
- RS-485

### FEATURES

- HIGH SURGE CAPABILITY TRANSIL ARRAY  
 $I_{PP} = 40 \text{ A (8/20}\mu\text{s)}$
- PEAK PULSE POWER : 300 W (8/20 $\mu\text{s}$ )
- SEPARATED INPUT-OUTPUT
- UP TO 9 BIDIRECTIONAL TRANSIL FUNCTIONS
- LOW CLAMPING FACTOR ( $V_{CL} / V_{BR}$ ) AT HIGH CURRENT LEVEL
- LOW LEAKAGE CURRENT
- ESD PROTECTION UP TO 15kV

### DESCRIPTION

Transil diode arrays provide high overvoltage protection by clamping action. Their instantaneous response to transient overvoltages makes them particularly suited to protect voltage sensitive devices such as MOS Technology and low voltage supplied IC's.

The ITA series allies high surge capability against energetic pulses with high voltage performance against ESD.

The separated input/output configuration of the device ensures improved protection against very fast transient overvoltage like ESD by elimination of the spikes induced by parasitic inductances created by external wiring.

### COMPLIES WITH THE FOLLOWING STANDARDS :

- IEC 1000-4-2 : level 4
- IEC 1000-4-4 : level 4
- IEC 1000-4-5 : level 2

MIL STD 883C - Method 3015-6 : class 3  
(human body model)

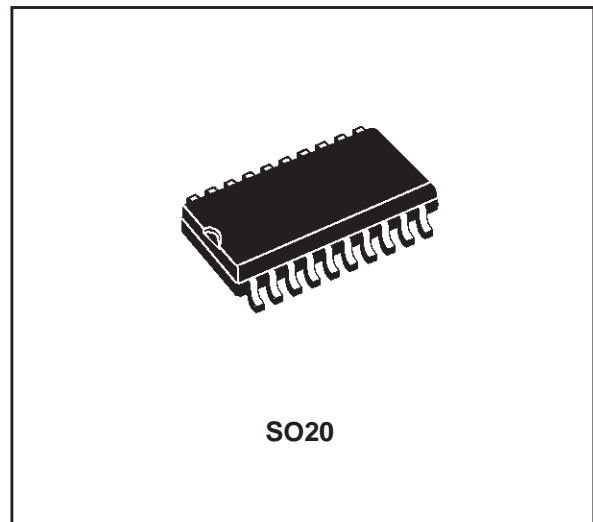

### FUNCTIONAL DIAGRAM

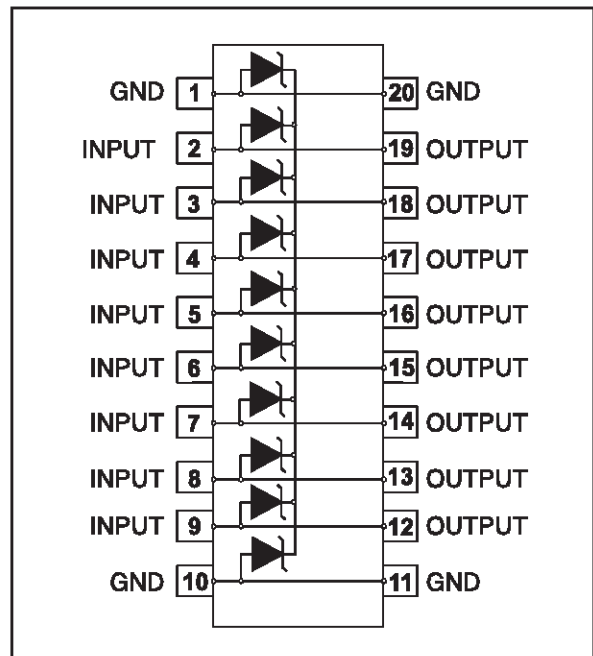

## ITA6V5B3 / ITA10B3 / ITA18B3 / ITA25B3

### ABSOLUTE MAXIMUM RATINGS ( $T_{amb} = 25^{\circ}\text{C}$ )

Symbol	Parameter		Value	Unit
$P_{PP}$	Peak pulse power dissipation (8/20 $\mu\text{s}$ ) (see note 1)	$T_j \text{ initial} = T_{amb}$	300	W
$I_{PP}$	Peak pulse current (8/20 $\mu\text{s}$ ) (see note 1)	$T_j \text{ initial} = T_{amb}$	40	A
$I^2t$	Wire $I^2t$ value (see note 1)		0.6	$\text{A}^2\text{s}$
$T_{stg}$ $T_j$	Storage temperature range Maximum operating junction temperature		- 55 to + 150 125	$^{\circ}\text{C}$ $^{\circ}\text{C}$
$T_L$	Maximum lead temperature for soldering during 10s		260	$^{\circ}\text{C}$

**Note 1 :** For surges greater than the specified maximum value, the I/O will first present a short-circuit and after an open circuit caused by the wire melting.

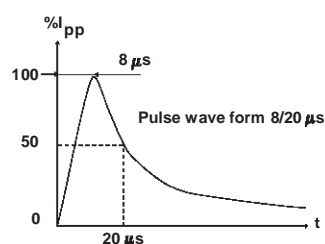

### ELECTRICAL CHARACTERISTICS ( $T_{amb} = 25^{\circ}\text{C}$ )

Symbol	Parameter
$V_{RM}$	Stand-off voltage
$V_{BR}$	Breakdown voltage
$V_{CL}$	Clamping voltage
$I_{RM}$	Leakage current @ $V_{RM}$
$I_{PP}$	Peak pulse current
$\alpha T$	Voltage temperature coefficient
C	Junction capacitance

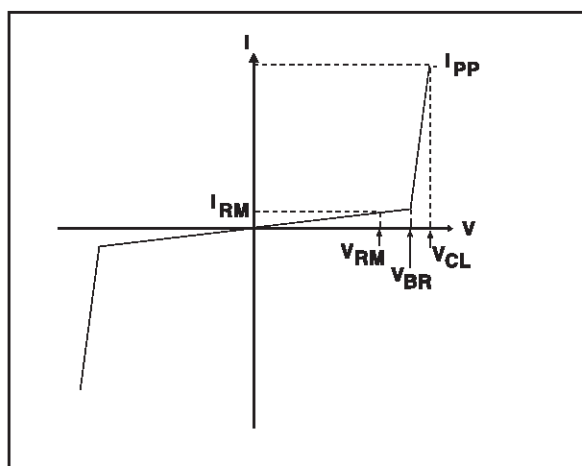

Types	$I_{RM}$ @ $V_{RM}$ max.		$V_{BR}$ @ $I_R$ min. note 2		$V_{CL}$ @ $I_{PP}$ 8/20 $\mu\text{s}$ note 2		$V_{CL}$ @ $I_{PP}$ max. 8/20 $\mu\text{s}$ note 2		$\alpha T$ max.	C max. note 3
	$\mu\text{A}$	V	V	mA	V	A	V	A	$10^{-4}/^{\circ}\text{C}$	pF
<b>ITA6V5B3</b>	<b>10</b>	<b>5</b>	<b>6.5</b>	<b>1</b>	<b>9.5</b>	<b>10</b>	<b>11</b>	<b>25</b>	<b>4</b>	<b>1100</b>
ITA10B3	4	8	10	1	13	10	17	25	8	800
ITA18B3	4	15	18	1	21	10	26	25	9	500
<b>ITA25B3</b>	<b>4</b>	<b>24</b>	<b>25</b>	<b>1</b>	<b>31</b>	<b>10</b>	<b>36</b>	<b>25</b>	<b>12</b>	<b>420</b>

**Note 2 :** Between I/O pin and ground.

**Note 3 :** Between two input Pins at 0V Bias.

Preferred types in bold.

Fig. 1 : Typical peak pulse power versus exponential pulse duration.

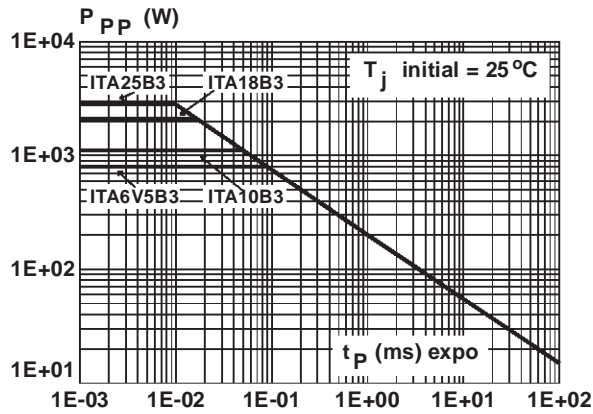

Fig. 2 : Clamping voltage versus peak pulse current (exponential waveform 8/20 μs).

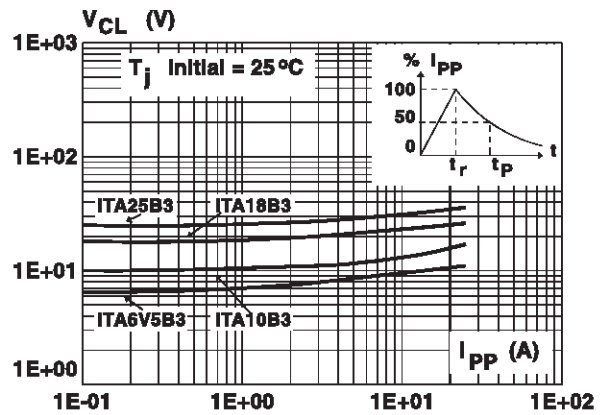

Fig. 3 : Peak current I<sub>DC</sub> inducing open circuit of the wire for one input/output versus pulse duration (typical values).

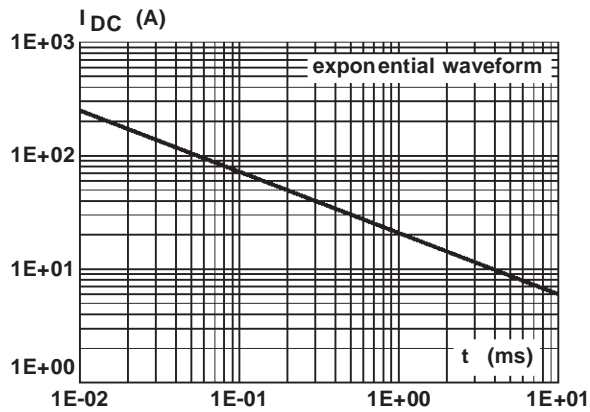

Fig. 4 : Junction capacitance versus reverse applied voltage for one input/output (typical values).

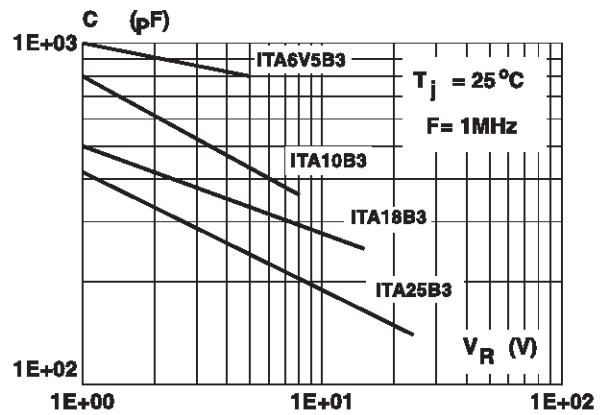
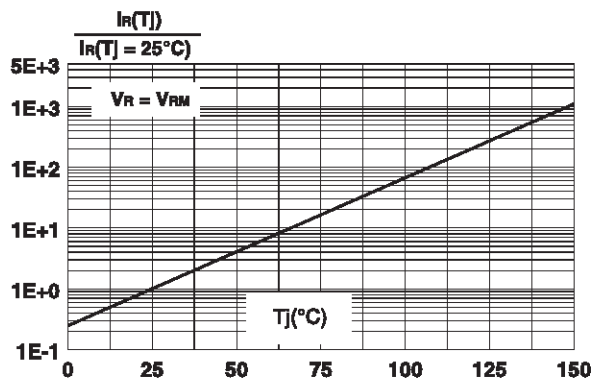

Fig. 5 : Relative variation of leakage current versus junction temperature



## ITA6V5B3 / ITA10B3 / ITA18B3 / ITA25B3

### APPLICATION INFORMATION

Types	Maximum differential voltage between two input pins at 25°C
ITA6V5B3	+ / - 3.5 V
ITA10B3	+ / - 5.0 V
ITA18B3	+ / - 9.0 V
ITA25B3	+ / - 12.5 V

This monolithic Transil Array is based on 10 unidirectional Transils with a common cathode and can be configured to offer up to 9 bidirectional functions. This imposes a maximum differential voltage between 2 input pins (see opposite table).

Typical application : RS232 junction.

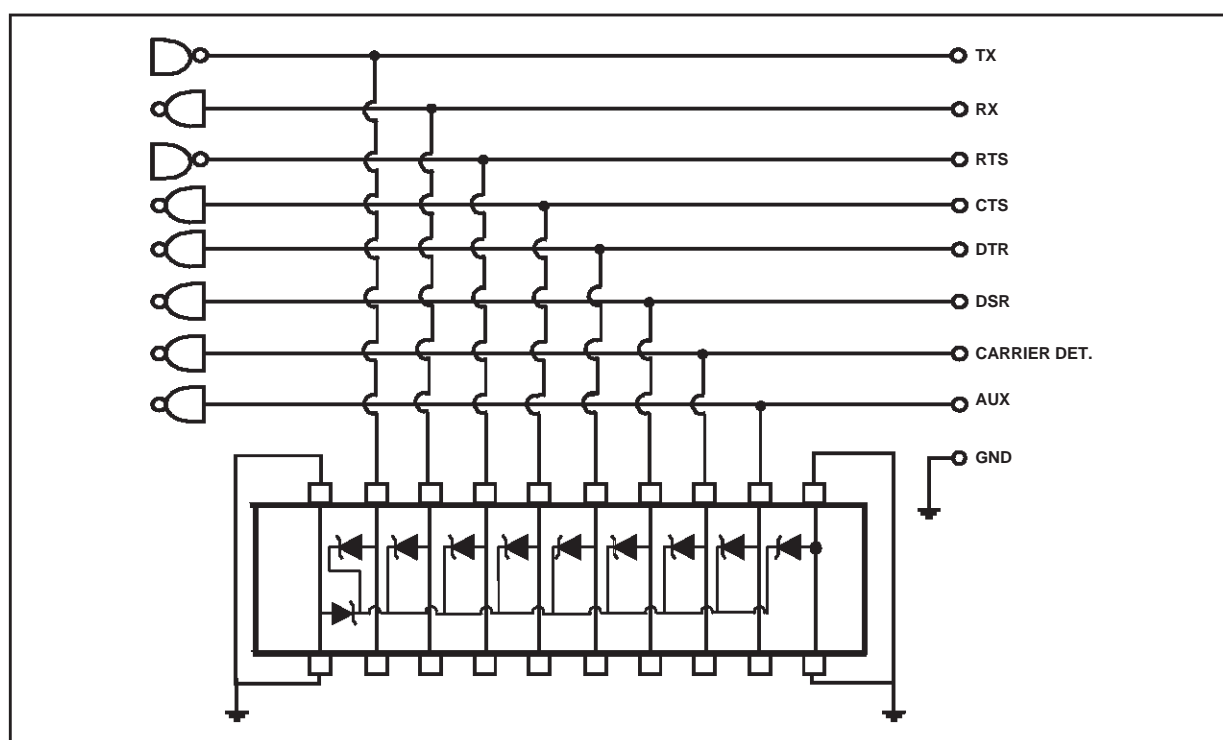

**APPLICATION NOTICE**

**Design advantage of ITAxxxB3 used with 4-point structure.**

The ITAxxxB3 has been designed with a 4-point structure (separated Input/output) in order to efficiently protect against disturbances with very high di/dt rates, such as ESD.

The purpose of this 4-point structure is to eliminate the overvoltage introduced by the parasitic inductances of the wiring ( $L di/dt$ ).

Efficient protection depends not only on the component itself, but also on the circuit layout. The drawing given in figure shows the layout to be used in order to take advantage of the 4-point structure of the ITAxxxB3.

With this layout, each line to be protected passes through the protection device.

In this way, it realizes an interface between the data line and the circuit to be protected, guaranteeing an isolation between its inputs and outputs.

**The 4 - point structure layout.**

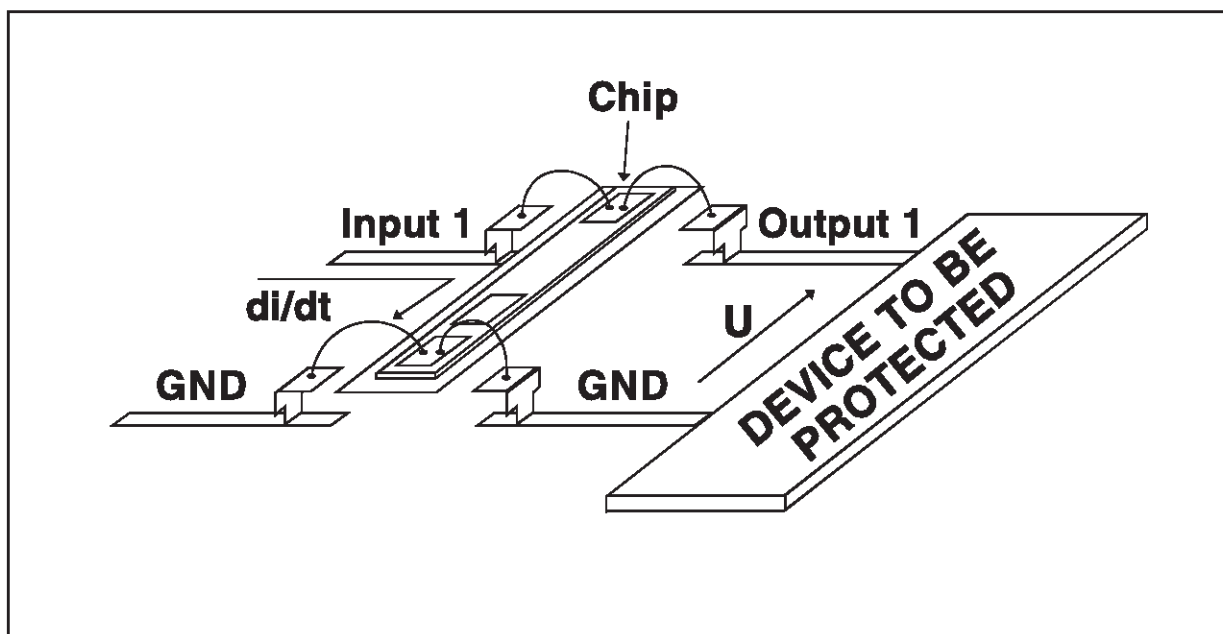

**ORDER CODE**

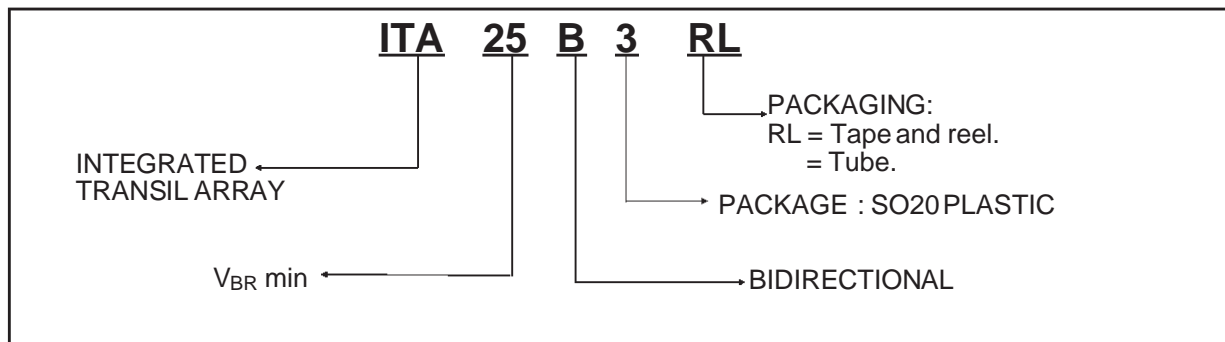

**ITA6V5B3 / ITA10B3 / ITA18B3 / ITA25B3**

**MARKING**

TYPE	MARKING
ITA6V5B3	ITA6V5B2
ITA10B3	ITA10B3
ITA18B3	ITA18B3
ITA25B3	ITA25B3

**PACKAGE MECHANICAL DATA**  
SO20 (Plastic)

REF.	DIMENSIONS					
	Millimetres			Inches		
	Min.	Typ.	Max.	Min.	Typ.	Max.
A			2.65			0.104
A1	0.10		0.20	0.004		0.008
B	0.33		0.51	0.013		0.020
C	0.23		0.32	0.009		0.013
D	12.6		13.0	0.484		0.512
E	7.40		7.60	0.291		0.299
e		1.27			0.050	
H	10.0		10.65	0.394		0.419
h		0.50			0.020	
L	0.50		1.27	0.020		0.050
K	8° (max)					

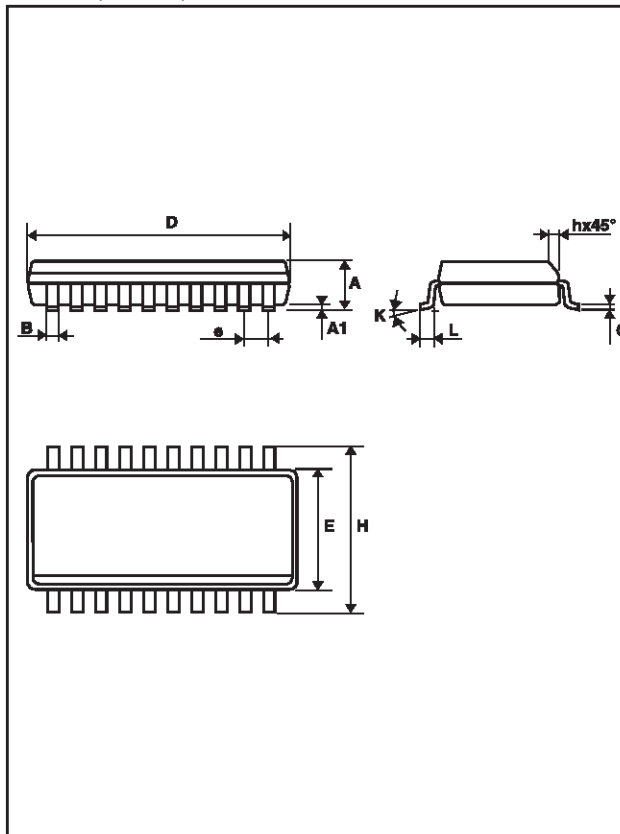

**Packaging:** standard packaging is tape and reel.

**Weight:** 0.55g.

Information furnished is believed to be accurate and reliable. However, SGS-THOMSON Microelectronics assumes no responsibility for the consequences of use of such information nor for any infringement of patents or other rights of third parties which may result from its use. No license is granted by implication or otherwise under any patent or patent rights of SGS-THOMSON Microelectronics. Specifications mentioned in this publication are subject to change without notice. This publication supersedes and replaces all information previously supplied. SGS-THOMSON Microelectronics products are not authorized for use as critical components in life support devices or systems without express written approval of SGS-THOMSON Microelectronics.

© 1998 SGS-THOMSON Microelectronics - Printed in Italy - All rights reserved.

SGS-THOMSON Microelectronics GROUP OF COMPANIES

Australia - Brazil - Canada - China - France - Germany - Italy - Japan - Korea - Malaysia - Malta - Morocco  
The Netherlands - Singapore - Spain - Sweden - Switzerland - Taiwan - Thailand - United Kingdom - U.S.A.



LittleDiode supplies new, hard to find or obsolete electronic components and semiconductors all over the world.

With over two million different components listed you are sure to find the part you need.

Feel free to visit us today at our online store:

[LittleDiode.com](http://LittleDiode.com)

Looking forward to providing you with the best possible service.