

Switchable Current Regulators

IXCP10M90S
IXCY10M90S

$V_{AK} = 900\text{ V}$
 $I_{A(P)} = 1 - 100\text{ mA}$
 $R_{DYN} = 100\text{ k}\Omega$

Symbol	Test Condition	Maximum Ratings	
V_{AKR}	$T_J = 25^\circ\text{C to } 150^\circ\text{C}$	900	V
V_{AGR}	$T_J = 25^\circ\text{C to } 150^\circ\text{C}$	900	V
V_{GK}		± 20	V
I_D	$T_C = 25^\circ\text{C}$	-0.3	A
P_D	$T_C = 25^\circ\text{C}$	40	W
T_J		-55 ... +150	$^\circ\text{C}$
T_{stg}		-55 ... +150	$^\circ\text{C}$
T_L	Temperature for Soldering (max. 10 s)	260	$^\circ\text{C}$
M_D	Mounting torque with screw M3 (TO-220) with screw M3.5 (TO-220)	0.45/4 0.55/5	Nm/lb.in.

TO-220 AB (IXCP)

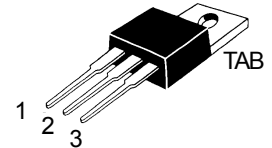

TO-252 AA (IXCY)

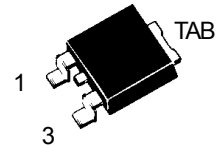

Pin connections

1 = Gate(G), Control terminal;
2 and tab = A (+) Positive terminal
3 = K (-), Negative terminal

Symbol	Test Condition	Characteristic Values ($T_J = 25^\circ\text{C}$ unless otherwise specified)		
		min.	typ.	max.
V_{AKR}	$R_K = 300\ \Omega$, (Fig. 1)	900		V
$I_{A(P)}$	$V_D = 10\text{ V}$; $R_K = 300\ \Omega$; (Fig. 2)	7	9	15 mA
$V_{GK(off)}$	$I_D = 100\ \mu\text{A}$; $V_D = 900\text{ V}$ Fig. 4	-5		V
$I_{D(P)}$	$V_D = 720\text{ V}$; $V_{GK} = -10\text{ V}$ (Fig. 1)			25 μA
$\Delta V_{AK} / \Delta I_{A(P)}$	Dynamic resistance; $V_D = 10\text{ V}$ $R_K = 300\ \Omega$; (Fig. 1)	100		k Ω
R_{thJC}	Thermal Resistance junction-to-case			3.1 K/W
R_{thJA}	Thermal Resistance junction-to-ambient			80 K/W
				100 K/W

Features

- Minimum of 900 V breakdown
- Resistor programmable current source
- 40 W continuous dissipation
- International standard packages JEDEC TO-220 and TO-252
- On/Off switchable current source

Applications

- Highly stable voltage sources
- Current surge limiters
- Transient voltage protection
- Instantaneously reacting resettable fuses
- Soft start-up circuits

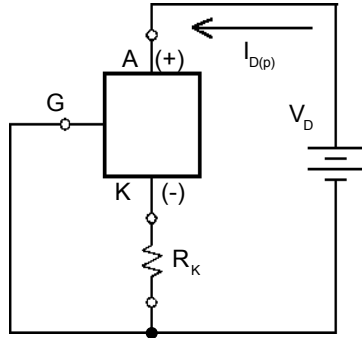

Fig. 1 Resistor R_K in series with negative pin to achieve different current levels

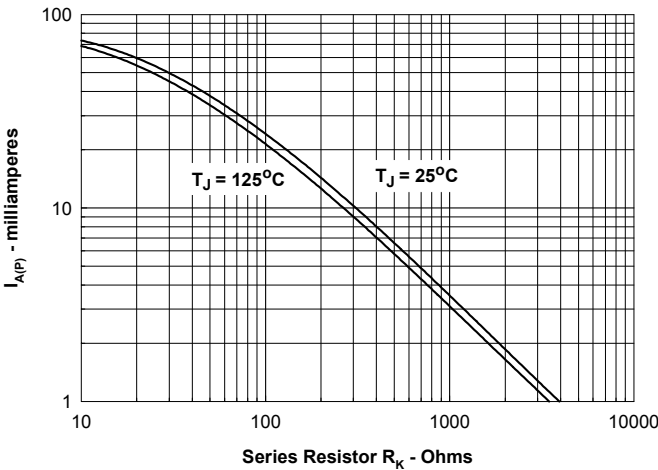

Fig. 2. Plateau current versus external resistance

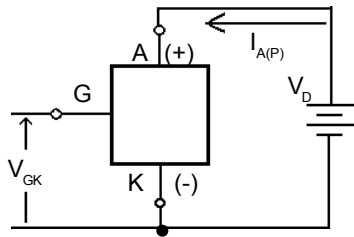

Fig. 3. Current regulator controlled by V_G

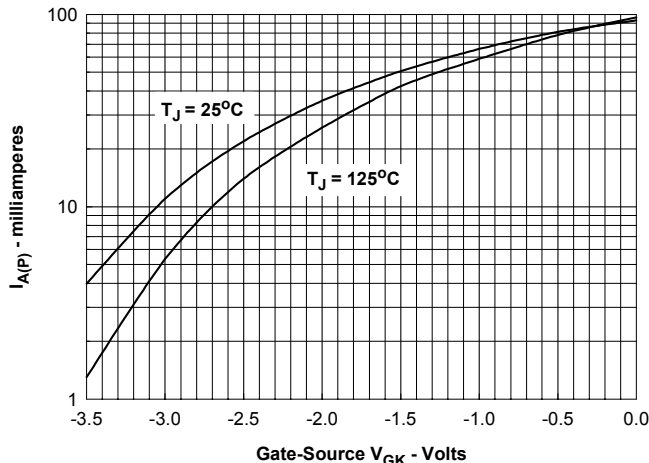
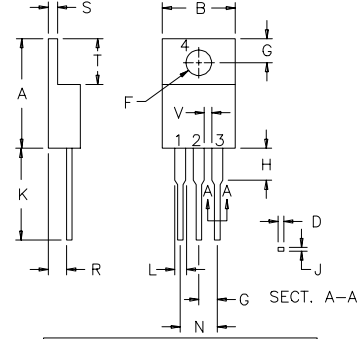

Fig. 4. Plateau current versus applied input voltage

TO-220 AB Outline



Dim.	Millimeter		Inches	
	Min.	Max.	Min.	Max.
A	14.23	16.51	.560	.650
B	9.66	10.66	.380	.420
C	3.56	4.82	.140	.190
D	0.64	0.89	.025	.035
F	3.54	4.06	.139	.161
G	2.29	2.79	.090	.110
H	-	6.35	-	.250
J	0.51	0.76	.020	.030
K	12.70	14.73	.500	.580
L	1.15	1.77	.045	.070
N	4.83	5.33	.190	.210
Q	2.54	3.42	.100	.135
R	2.04	2.49	.080	.115
S	0.64	1.39	.025	.055
T	5.85	6.85	2.30	2.70
V	1.15	-	.045	-

TO-252 AA Outline

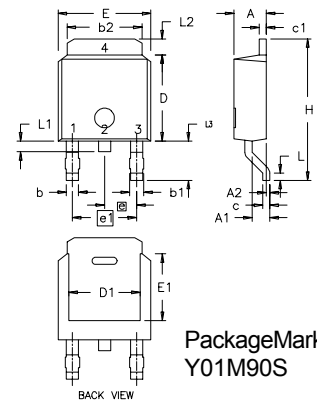

Dim.	Millimeter		Inches	
	Min.	Max.	Min.	Max.
A	2.19	2.38	0.086	0.094
A1	0.89	1.14	0.035	0.045
A2	0	0.13	0	0.005
b	0.64	0.89	0.025	0.035
b1	0.76	1.14	0.030	0.045
b2	5.21	5.46	0.205	0.215
c	0.46	0.58	0.018	0.023
c1	0.46	0.58	0.018	0.023
D	5.97	6.22	0.235	0.245
D1	4.32	5.21	0.170	0.205
E	6.35	6.73	0.250	0.265
E1	4.32	5.21	0.170	0.205
e	2.28	BSC	0.090	BSC
e1	4.57	BSC	0.180	BSC
H	9.40	10.42	0.370	0.410
L	0.51	1.02	0.020	0.040
L1	0.64	1.02	0.025	0.040
L2	0.89	1.27	0.035	0.050
L3	2.54	2.92	0.100	0.115

IXYS reserves the right to change limits, test conditions, and dimensions.

IXYS MOSFETS and IGBTs are covered by one or more of the following U.S. patents: 4,835,592 4,881,106 5,017,508 5,049,961 5,187,117 5,486,715
4,850,072 4,931,844 5,034,796 5,063,307 5,237,481 5,381,025



LittleDiode supplies new, hard to find or obsolete electronic components and semiconductors all over the world.

With over two million different components listed you are sure to find the part you need.

Feel free to visit us today at our online store:

LittleDiode.com

Looking forward to providing you with the best possible service.