

## Document Title

128Kx8 bit Low Power CMOS Static RAM

## Revision History

<u>Revision No.</u>	<u>History</u>	<u>Draft Data</u>	<u>Remark</u>
0.0	Design target	October 12, 1998	Preliminary
1.0	Finalize - Improve twp form 55ns to 50ns for 70ns product. - Remove 55ns speed bin from industrial product.	August 30, 1999	Final
1.01	Errata correction	December 1, 1999	
2.0	Revise	February 14, 2000	Final
3.0	Revise - Add 55ns parts to industrial products.	March 3, 2000	Final

---

The attached datasheets are provided by SAMSUNG Electronics. SAMSUNG Electronics CO., LTD. reserves the right to change the specifications and products. SAMSUNG Electronics will answer to your questions. If you have any questions, please contact the SAMSUNG branch offices.

---

## 128Kx8 bit Low Power CMOS Static RAM

### FEATURES

- Process Technology: TFT
- Organization: 128Kx8
- Power Supply Voltage: 4.5–5.5V
- Low Data Retention Voltage: 2V(Min)
- Three state output and TTL Compatible
- Package Type: 32-DIP-600, 32-SOP-525, 32-TSOP1-0820F/R

### GENERAL DESCRIPTION

The K6T1008C2E families are fabricated by SAMSUNG's advanced CMOS process technology. The families support various operating temperature ranges and have various package types for user flexibility of system design. The families also support low data retention voltage for battery back-up operation with low data retention current.

### PRODUCT FAMILY

Product Family	Operating Temperature	Vcc Range	Speed	Power Dissipation		PKG Type
				Standby (I <sub>SB1</sub> , Max)	Operating (I <sub>CC2</sub> , Max)	
K6T1008C2E-L	Commercial(0~70°C)	4.5~5.5V	55 <sup>1)</sup> /70ns	50µA	50mA	32-DIP-600, 32-SOP-525 32-TSOP1-0820F/R
K6T1008C2E-B				10µA		
K6T1008C2E-P	Industrial(-40~85°C)			50µA		
K6T1008C2E-F				15µA		32-SOP-525 32-TSOP1-0820F/R

1. The parameters are tested with 50pF test load

### PIN DESCRIPTION

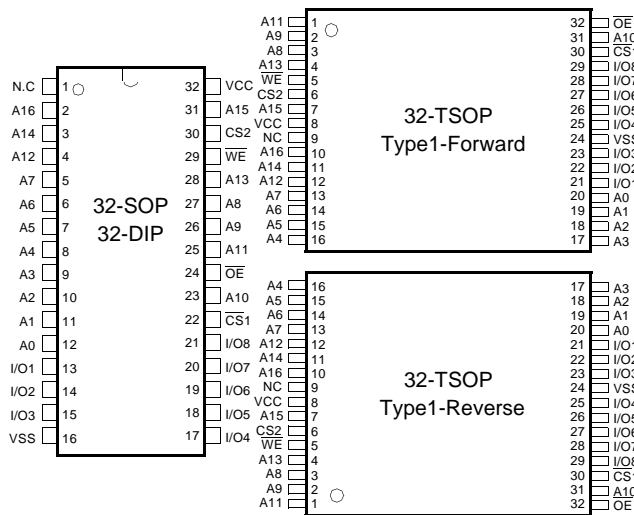

Name	Function
$\overline{CS}_1, \overline{CS}_2$	Chip Select Input
$\overline{OE}$	Output Enable Input
$\overline{WE}$	Write Enable Input
I/O <sub>1</sub> ~I/O <sub>8</sub>	Data Inputs/Outputs
A <sub>0</sub> ~A <sub>16</sub>	Address Inputs
V <sub>cc</sub>	Power
V <sub>ss</sub>	Ground
N.C.	No Connection

### FUNCTIONAL BLOCK DIAGRAM

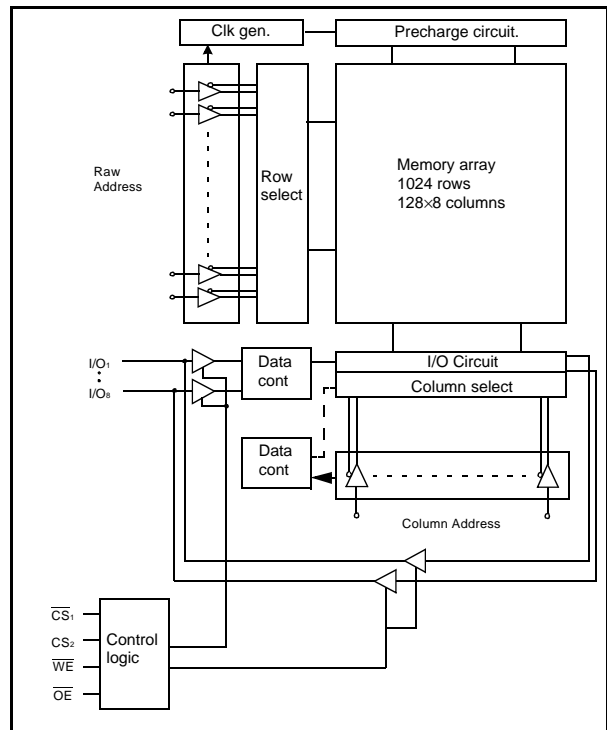

SAMSUNG ELECTRONICS CO., LTD. reserves the right to change products and specifications without notice.

## PRODUCT LIST

Commercial Temperature Products(0~70°C)		Industrial Temperature Products(-40~85°C)	
Part Name	Function	Part Name	Function
K6T1008C2E-DL55	32-DIP, 55ns, Low Power	K6T1008C2E-GP55	32-SOP, 55ns, Low Power
K6T1008C2E-DL70	32-DIP, 70ns, Low Power	K6T1008C2E-GP70	32-SOP, 70ns, Low Power
K6T1008C2E-DB55	32-DIP, 55ns, Low Low Power	K6T1008C2E-GF55	32-SOP, 55ns, Low Low Power
K6T1008C2E-DB70	32-DIP, 70ns, Low Low Power	K6T1008C2E-GF70	32-SOP, 70ns, Low Low Power
K6T1008C2E-GL55	32-SOP, 55ns, Low Power	K6T1008C2E-TF55	32-TSOP F, 55ns, Low Low Power
K6T1008C2E-GL70	32-SOP, 70ns, Low Power	K6T1008C2E-TF70	32-TSOP F, 70ns, Low Low Power
K6T1008C2E-GB55	32-SOP, 55ns, Low Low Power	K6T1008C2E-RF55	32-TSOP R, 55ns, Low Low Power
K6T1008C2E-GB70	32-SOP, 70ns, Low Low Power	K6T1008C2E-RF70	32-TSOP R, 70ns, Low Low Power
K6T1008C2E-TB55	32-TSOP F, 55ns, Low Low Power		
K6T1008C2E-TB70	32-TSOP F, 70ns, Low Low Power		
K6T1008C2E-RB55	32-TSOP R, 55ns, Low Low Power		
K6T1008C2E-RB70	32-TSOP R, 70ns, Low Low Power		

## FUNCTIONAL DESCRIPTION

CS <sub>1</sub>	CS <sub>2</sub>	OE	WE	I/O	Mode	Power
H	X <sup>1)</sup>	X <sup>1)</sup>	X <sup>1)</sup>	High-Z	Deselected	Standby
X <sup>1)</sup>	L	X <sup>1)</sup>	X <sup>1)</sup>	High-Z	Deselected	Standby
L	H	H	H	High-Z	Output Disabled	Active
L	H	L	H	Dout	Read	Active
L	H	X <sup>1)</sup>	L	Din	Write	Active

1. X means don't care (Must be in high or low states)

## ABSOLUTE MAXIMUM RATINGS<sup>1)</sup>

Item	Symbol	Ratings	Unit	Remark
Voltage on any pin relative to V <sub>ss</sub>	V <sub>IN</sub> , V <sub>OUT</sub>	-0.5 to 7.0	V	-
Voltage on V <sub>cc</sub> supply relative to V <sub>ss</sub>	V <sub>CC</sub>	-0.5 to 7.0	V	-
Power Dissipation	P <sub>D</sub>	1.0	W	-
Storage temperature	T <sub>STG</sub>	-65 to 150	°C	-
Operating Temperature	T <sub>A</sub>	0 to 70	°C	K6T1008C2E-L/-B
		-40 to 85	°C	K6T1008C2E-P/-F

1. Stresses greater than those listed under "Absolute Maximum Ratings" may cause permanent damage to the device. Functional operation should be restricted to recommended operating condition. Exposure to absolute maximum rating conditions for extended periods may affect reliability.

RECOMMENDED DC OPERATING CONDITIONS<sup>1)</sup>

Item	Symbol	Product	Min	Typ	Max	Unit
Supply voltage	V <sub>CC</sub>	K6T1008C2E Family	4.5	5.0	5.5	V
Ground	V <sub>SS</sub>	All Family	0	0	0	V
Input high voltage	V <sub>IH</sub>	K6T1008C2E Family	2.2	-	V <sub>CC</sub> +0.5 <sup>2)</sup>	V
Input low voltage	V <sub>IL</sub>	K6T1008C2E Family	-0.5 <sup>3)</sup>	-	0.8	V

Note:

- Commercial Product: T<sub>A</sub>=0 to 70°C  
Industrial Product: T<sub>A</sub>=-40 to 85°C, otherwise specified.
- Overshoot: V<sub>CC</sub>+3.0V in case of pulse width≤30ns.
- Undershoot: -3.0V in case of pulse width≤30ns.
- Overshoot and undershoot are sampled, not 100% tested.

CAPACITANCE<sup>1)</sup> (f=1MHz, T<sub>A</sub>=25°C)

Item	Symbol	Test Condition	Min	Max	Unit
Input capacitance	C <sub>IN</sub>	V <sub>IN</sub> =0V	-	6	pF
Input/Output capacitance	C <sub>IO</sub>	V <sub>IO</sub> =0V	-	8	pF

- Capacitance is sampled, not 100% tested

## DC AND OPERATING CHARACTERISTICS

Item	Symbol	Test Conditions	Min	Typ	Max	Unit
Input leakage current	I <sub>LI</sub>	V <sub>IN</sub> =V <sub>SS</sub> to V <sub>CC</sub>	-1	-	1	μA
Output leakage current	I <sub>LO</sub>	$\overline{CS}_1=V_{IH}$ or $CS_2=V_{IL}$ or $\overline{OE}=V_{IH}$ or $\overline{WE}=V_{IL}$ , V <sub>IO</sub> =V <sub>SS</sub> to V <sub>CC</sub>	-1	-	1	μA
Operating power supply current	I <sub>CC</sub>	I <sub>IO</sub> =0mA, $\overline{CS}_1=V_{IL}$ , CS <sub>2</sub> =V <sub>IH</sub> , V <sub>IN</sub> =V <sub>IH</sub> or V <sub>IL</sub> , Read	-	-	10	mA
Average operating current	I <sub>CC1</sub>	Cycle time=1μs, 100% duty, I <sub>IO</sub> =0mA, $\overline{CS}_1\leq 0.2V$ , CS <sub>2</sub> ≥V <sub>CC</sub> -0.2V, V <sub>IN</sub> ≤0.2V or V <sub>IN</sub> ≥V <sub>CC</sub> -0.2V	-	-	7	mA
	I <sub>CC2</sub>	Cycle time=Min, 100% duty, I <sub>IO</sub> =0mA, $\overline{CS}_1=V_{IL}$ , CS <sub>2</sub> =V <sub>IH</sub> , V <sub>IN</sub> =V <sub>IH</sub> or V <sub>IL</sub>	-	-	50	mA
Output low voltage	V <sub>OL</sub>	I <sub>OL</sub> =2.1mA	-	-	0.4	V
Output high voltage	V <sub>OH</sub>	I <sub>OH</sub> =-1.0mA	2.4	-	-	V
Standby Current(TTL)	I <sub>SB</sub>	$\overline{CS}_1=V_{IH}$ , CS <sub>2</sub> =V <sub>IL</sub> , Other inputs=V <sub>IH</sub> or V <sub>IL</sub>	-	-	3	mA
Standby Current(CMOS)	I <sub>SB1</sub>	$\overline{CS}_1\geq V_{CC}-0.2V$ , CS <sub>2</sub> ≥V <sub>CC</sub> -0.2V or CS <sub>2</sub> ≤0.2V, Other inputs=0~V <sub>CC</sub>	-	-	50 <sup>1)</sup>	μA

- 50μA for Low power product, in case of Low Low power products are commercial=10μA, industrial=15μA.

## AC OPERATING CONDITIONS

### TEST CONDITIONS (Test Load and Input/Output Reference)

Input pulse level: 0.8 to 2.4V  
 Input rising and falling time: 5ns  
 Input and output reference voltage: 1.5V  
 Output load (see right):  $C_L = 100\text{pF} + 1\text{TTL}$   
 $C_L = 50\text{pF} + 1\text{TTL}$

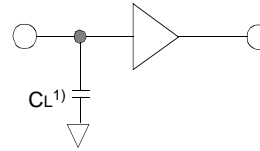

1. Including scope and jig capacitance

## AC CHARACTERISTICS ( $V_{CC} = 4.5 \sim 5.5\text{V}$ , Commercial Product: $T_A = 0$ to $70^\circ\text{C}$ , Industrial Product: $T_A = -40$ to $85^\circ\text{C}$ )

Parameter List		Symbol	Speed Bins				Units
			55ns		70ns		
			Min	Max	Min	Max	
Read	Read Cycle Time	t <sub>RC</sub>	55	-	70	-	ns
	Address Access Time	t <sub>AA</sub>	-	55	-	70	ns
	Chip Select to Output	t <sub>CO</sub>	-	55	-	70	ns
	Output Enable to Valid Output	t <sub>OE</sub>	-	25	-	35	ns
	Chip Select to Low-Z Output	t <sub>LZ</sub>	10	-	10	-	ns
	Output Enable to Low-Z Output	t <sub>OLZ</sub>	5	-	5	-	ns
	Chip Disable to High-Z Output	t <sub>HZ</sub>	0	20	0	25	ns
	Output Disable to High-Z Output	t <sub>OHZ</sub>	0	20	0	25	ns
	Output Hold from Address Change	t <sub>OH</sub>	10	-	10	-	ns
Write	Write Cycle Time	t <sub>WC</sub>	55	-	70	-	ns
	Chip Select to End of Write	t <sub>CW</sub>	45	-	60	-	ns
	Address Set-up Time	t <sub>AS</sub>	0	-	0	-	ns
	Address Valid to End of Write	t <sub>AW</sub>	45	-	60	-	ns
	Write Pulse Width	t <sub>WP</sub>	40	-	50	-	ns
	Write Recovery Time	t <sub>WR</sub>	0	-	0	-	ns
	Write to Output High-Z	t <sub>WHZ</sub>	0	20	0	25	ns
	Data to Write Time Overlap	t <sub>DW</sub>	20	-	25	-	ns
	Data Hold from Write Time	t <sub>DH</sub>	0	-	0	-	ns
	End Write to Output Low-Z	t <sub>OW</sub>	5	-	5	-	ns

## DATA RETENTION CHARACTERISTICS

Item	Symbol	Test Condition	Min	Typ	Max	Unit	
V <sub>CC</sub> for data retention	V <sub>DR</sub>	$\overline{CS}_1 \geq V_{CC} - 0.2\text{V}^1$	2.0	-	5.5	V	
Data retention current	I <sub>DR</sub>	$V_{CC} = 3.0\text{V}, \overline{CS}_1 \geq V_{CC} - 0.2\text{V}^1$	K6T1008C2E-L	-	-	20	$\mu\text{A}$
			K6T1008C2E-B	-	-	10	
			K6T1008C2E-P	-	-	25	
			K6T1008C2F-F	-	-	10	
Data retention set-up time	t <sub>SDR</sub>	See data retention waveform	0	-	-	ms	
Recovery time	t <sub>RDR</sub>		5	-	-		

1.  $\overline{CS}_1 \geq V_{CC} - 0.2\text{V}$ ,  $CS_2 \geq V_{CC} - 0.2\text{V}$  ( $\overline{CS}_1$  controlled) or  $CS_2 \leq 0.2\text{V}$  ( $CS_2$  controlled)

## TIMMING DIAGRAMS

**TIMING WAVEFORM OF READ CYCLE(1)** (Address Controlled,  $\overline{CS1}=\overline{OE}=V_{IL}$ ,  $CS2=\overline{WE}=V_{IH}$ )

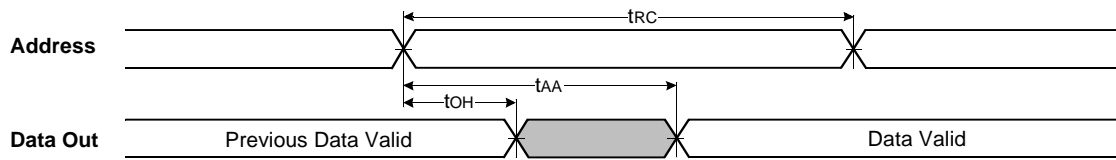

**TIMING WAVEFORM OF READ CYCLE(2)** ( $\overline{WE}=V_{IH}$ )

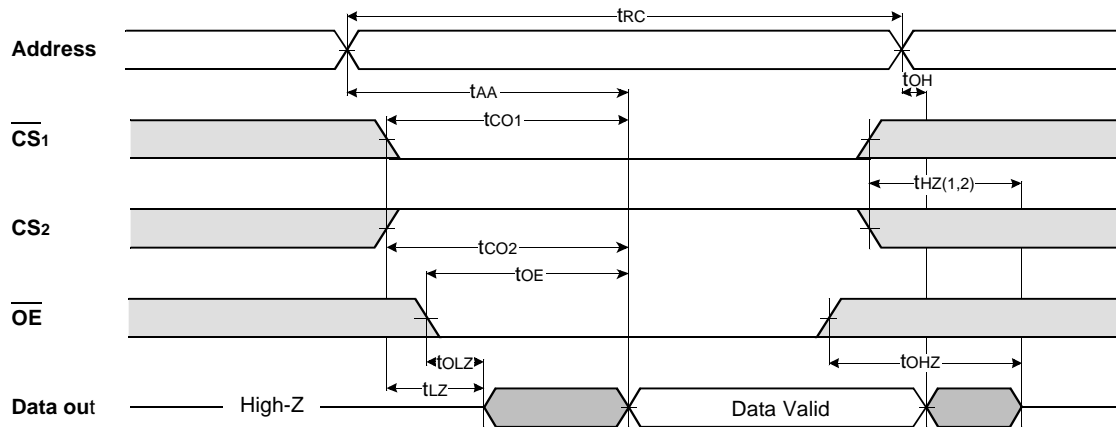

**NOTES (READ CYCLE)**

1.  $t_{HZ}$  and  $t_{OHZ}$  are defined as the time at which the outputs achieve the open circuit conditions and are not referenced to output voltage levels.
2. At any given temperature and voltage condition,  $t_{HZ}(\text{Max.})$  is less than  $t_{LZ}(\text{Min.})$  both for a given device and from device to device interconnection.

TIMING WAVEFORM OF WRITE CYCLE(1) ( $\overline{WE}$  Controlled)

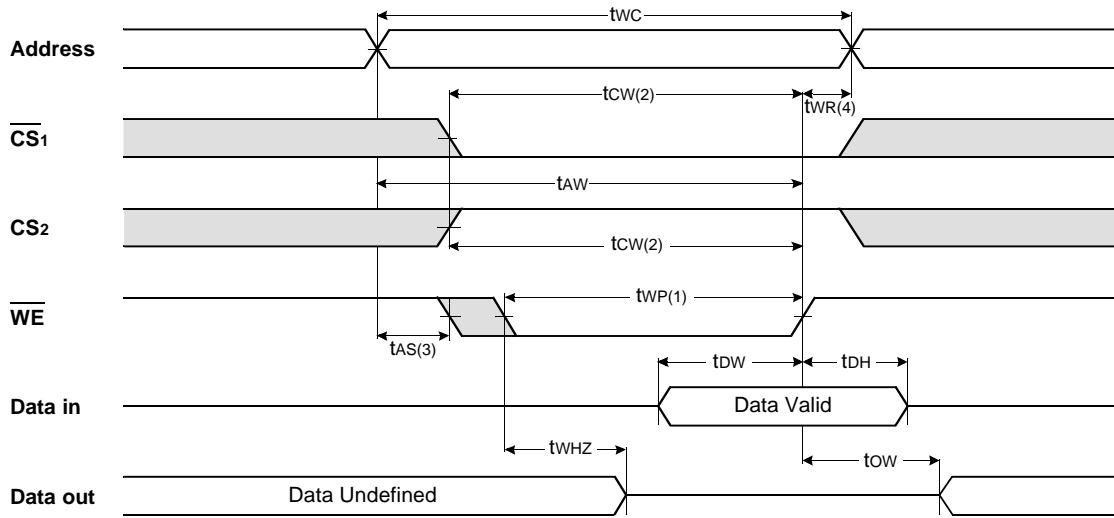

TIMING WAVEFORM OF WRITE CYCLE(2) ( $\overline{CS1}$  Controlled)

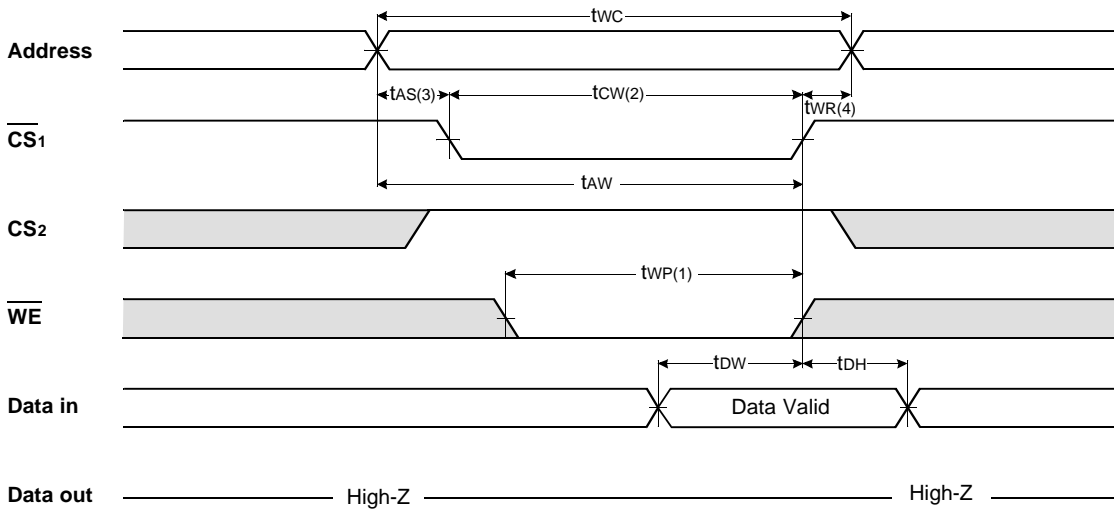

TIMING WAVEFORM OF WRITE CYCLE(3) (CS<sub>2</sub> Controlled)

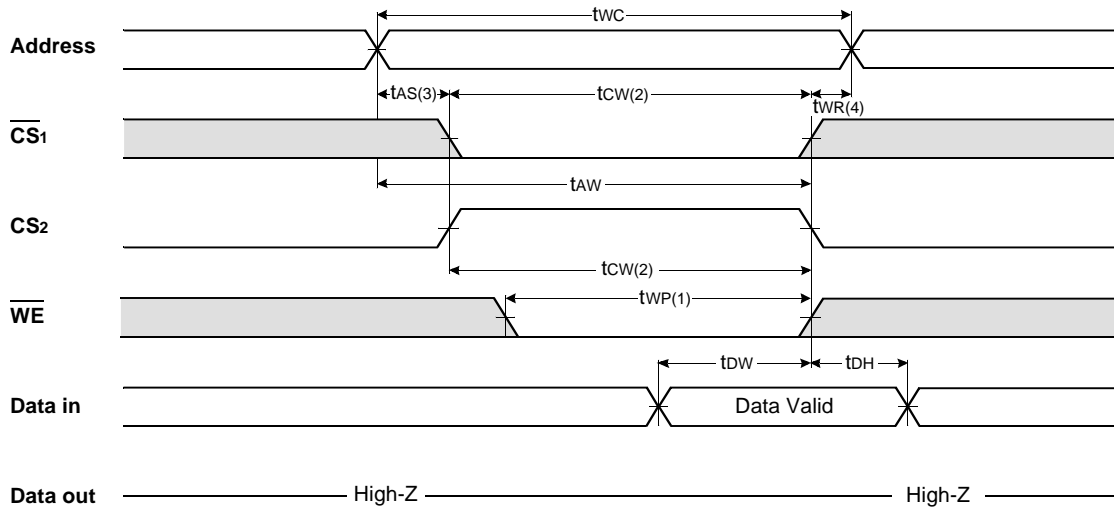

NOTES (WRITE CYCLE)

1. A write occurs during the overlap of a low  $\overline{CS}_1$ , a high  $CS_2$  and a low  $\overline{WE}$ . A write begins at the latest transition among  $\overline{CS}_1$  goes low,  $CS_2$  going high and  $\overline{WE}$  going low: A write ends at the earliest transition among  $\overline{CS}_1$  going high,  $CS_2$  going low and  $\overline{WE}$  going high:  $t_{WP}$  is measured from the beginning of write to the end of write.
2.  $t_{CW}$  is measured from the  $\overline{CS}_1$  going low or  $CS_2$  going high to the end of write.
3.  $t_{AS}$  is measured from the address valid to the beginning of write.
4.  $t_{WR}$  is measured from the end of write to the address change.  $t_{WR1}$  applied in case a write ends as  $\overline{CS}_1$  or  $\overline{WE}$  going high  $t_{WR2}$  applied in case a write ends as  $CS_2$  going to low.

DATA RETENTION WAVE FORM

CS<sub>1</sub> controlled

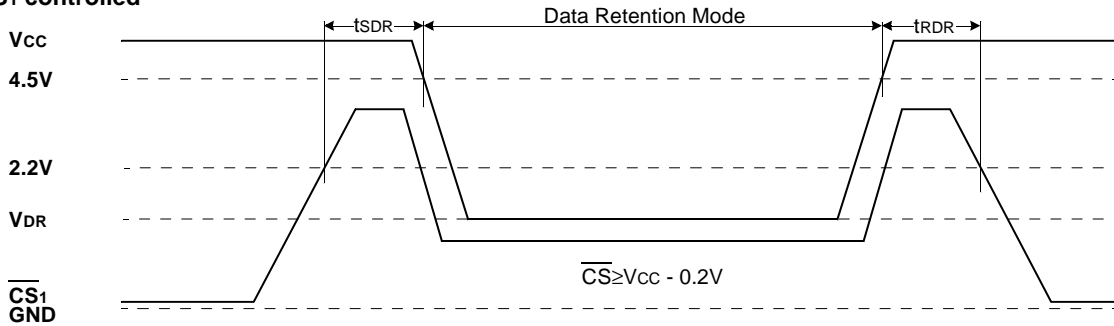

CS<sub>2</sub> controlled

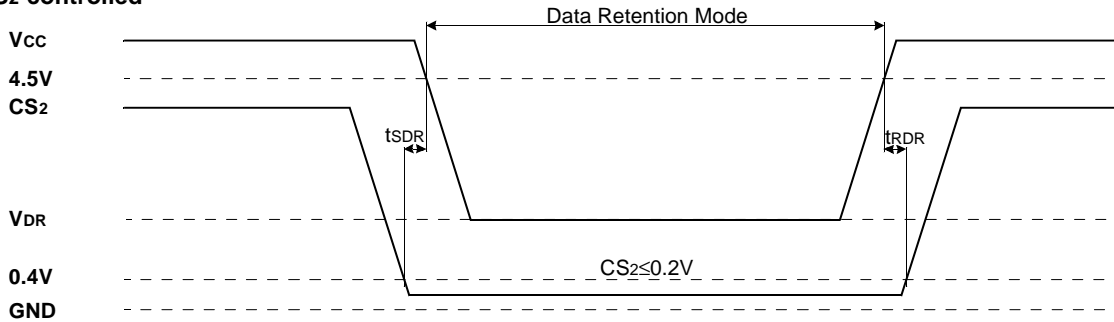

## PACKAGE DIMENSIONS

32 DUAL INLINE PACKAGE (600mil)

Units: millimeters( inches)

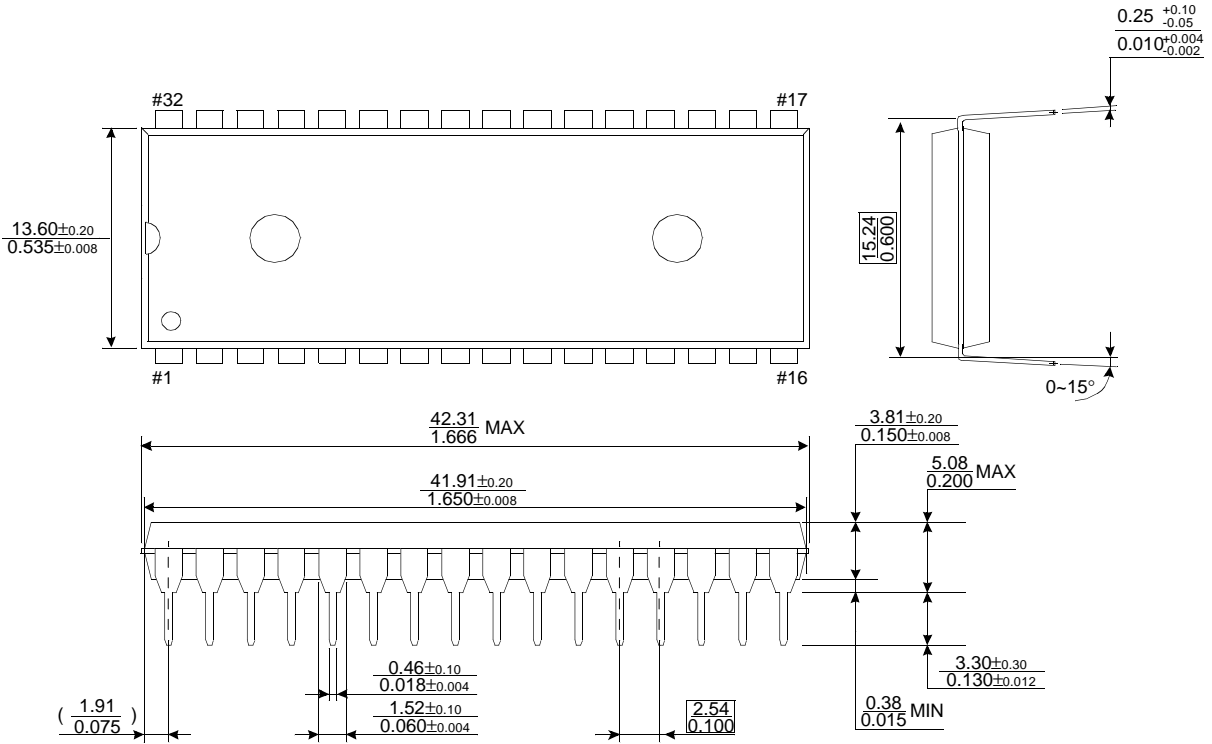

## 32 PLASTIC SMALL OUTLINE PACKAGE (525mil)

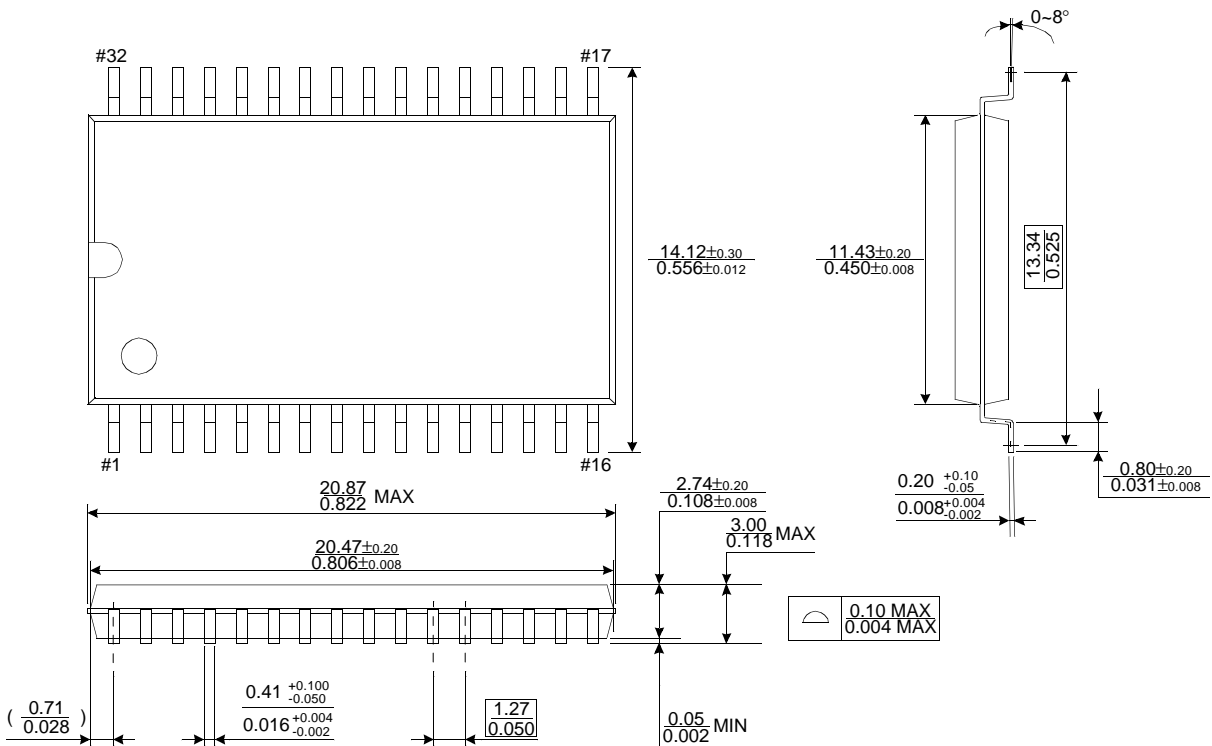

## PACKAGE DIMENSIONS

Units: millimeters(inches)

### 32 PIN THIN SMALL OUTLINE PACKAGE TYPE I (0820F)

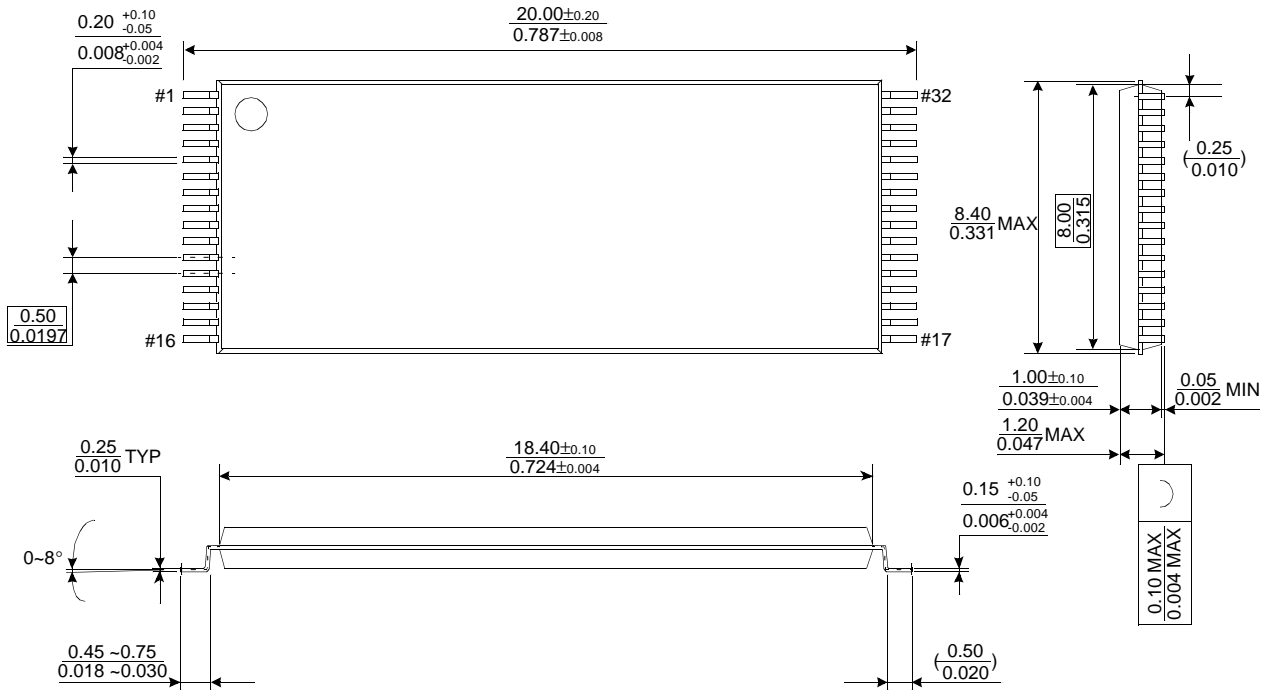

### 32 THIN SMALL OUTLINE PACKAGE TYPE I (0820R)

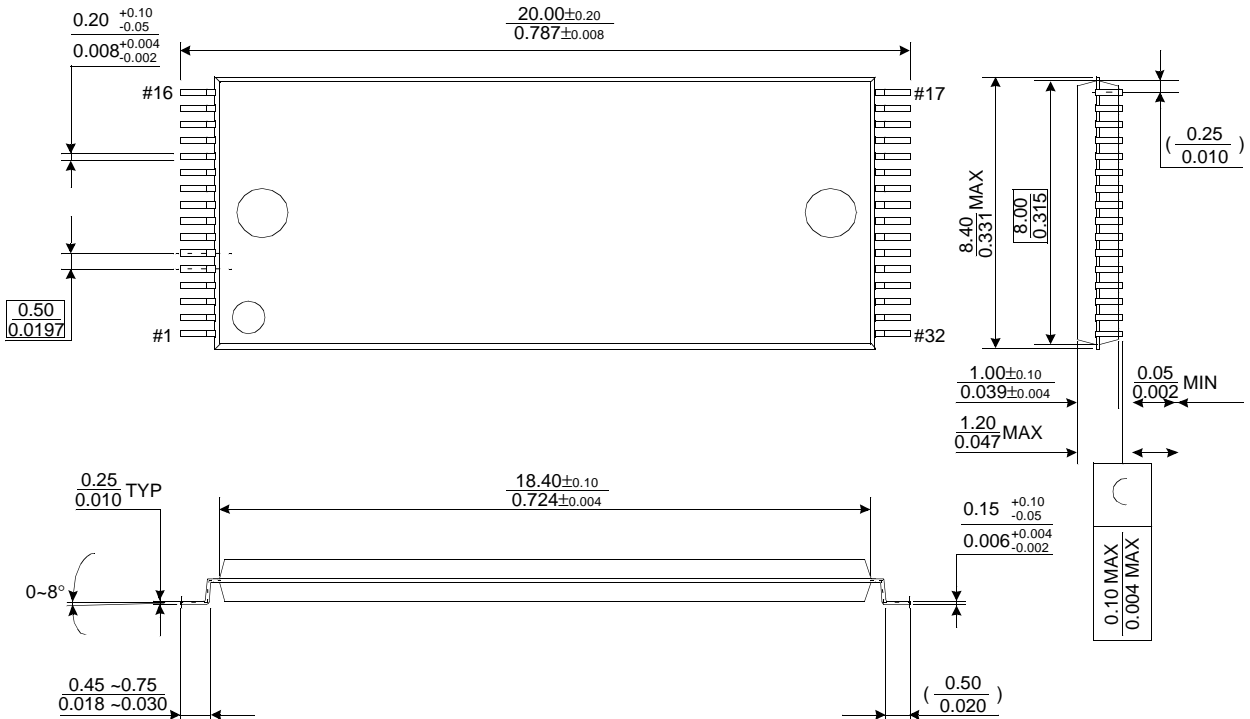

This datasheet has been downloaded from:

[www.DatasheetCatalog.com](http://www.DatasheetCatalog.com)

Datasheets for electronic components.



LittleDiode supplies new, hard to find or obsolete electronic components and semiconductors all over the world.

With over two million different components listed you are sure to find the part you need.

Feel free to visit us today at our online store:

[LittleDiode.com](http://LittleDiode.com)

Looking forward to providing you with the best possible service.