

Document Title**512Kx8 bit Low Power CMOS Static RAM****Revision History**

| <u>Revision No.</u> | <u>History</u> | <u>Draft Date</u> | <u>Remark</u> |
|----------------------------|--|--------------------------|----------------------|
| 0.0 | Initial Draft | December 7, 1996 | Advance |
| 0.1 | Revise - Changed Operating current by reticle revision Icc at write : 35mA → 45mA Icc1 at read/write : 15/35mA → 10/45mA | March 6, 1997 | Preliminary |
| 1.0 | Finalize - Changed Operating current Icc1 at write : 45mA → 40mA Icc2; 90mA → 80mA - Change test load at 55ns : 100pF → 50pF | October 9, 1997 | Final |
| 2.0 | Revise - Change datasheet format | February 17, 1998 | Final |
| 3.0 | Revise - Industrial product speed bin change:70/100ns → 55/70ns | September 8, 1998 | Final |

The attached datasheets are provided by SAMSUNG Electronics. SAMSUNG Electronics CO., LTD. reserve the right to change the specifications and products. SAMSUNG Electronics will answer to your questions about device. If you have any questions, please contact the SAMSUNG branch offices.

512Kx8 bit Low Power CMOS Static RAM

FEATURES

- Process Technology: TFT
- Organization: 512Kx8
- Power Supply Voltage: 4.5~5.5V
- Low Data Retention Voltage: 2V(Min)
- Three state output and TTL Compatible
- Package Type: 32-DIP-600, 32-SOP-525
32-TSOP2-400F/R

GENERAL DESCRIPTION

The K6T4008C1B families are fabricated by SAMSUNG's advanced CMOS process technology. The families support various operating temperature ranges and various package types for user flexibility of system design. The family also support low data retention voltage for battery back-up operation with low data retention current.

PRODUCT FAMILY

| Product Family | Operating Temperature | Vcc Range | Speed | Power Dissipation | | PKG Type |
|------------------------------|-----------------------|-----------|------------------------|----------------------------------|------------------------------------|---|
| | | | | Standby (I _{SB1} , Max) | Operating (I _{CC2} , Max) | |
| K6T4008C1B-L K6T4008C1B-B | Commercial (0~70°C) | 4.5~5.5V | 55 ¹⁾ /70ns | 100µA 20µA | 80mA | 32-DIP-600, 32-SOP-525 32-TSOP2-400F/R |
| K6T4008C1B-P K6T4008C1B-F | | | | 100µA 50µA | | |

1. The parameter is measured with 50pF test load.

PIN DESCRIPTION

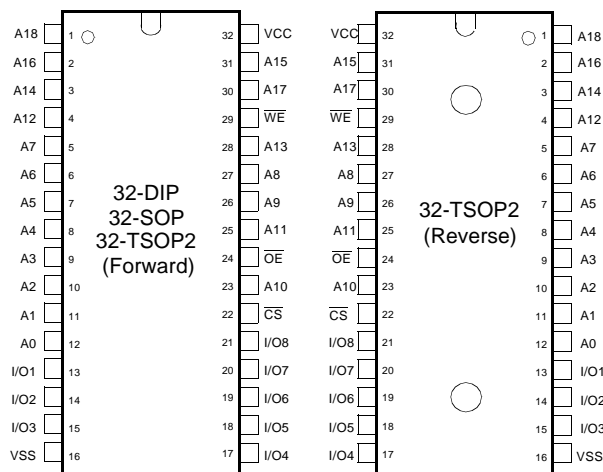

| Pin Name | Function |
|-----------------|---------------------|
| \overline{WE} | Write Enable Input |
| \overline{CS} | Chip Select Input |
| \overline{OE} | Output Enable Input |
| A0~A18 | Address Inputs |
| I/O1~I/O8 | Data Inputs/Outputs |
| Vcc | Power |
| Vss | Ground |

FUNCTIONAL BLOCK DIAGRAM

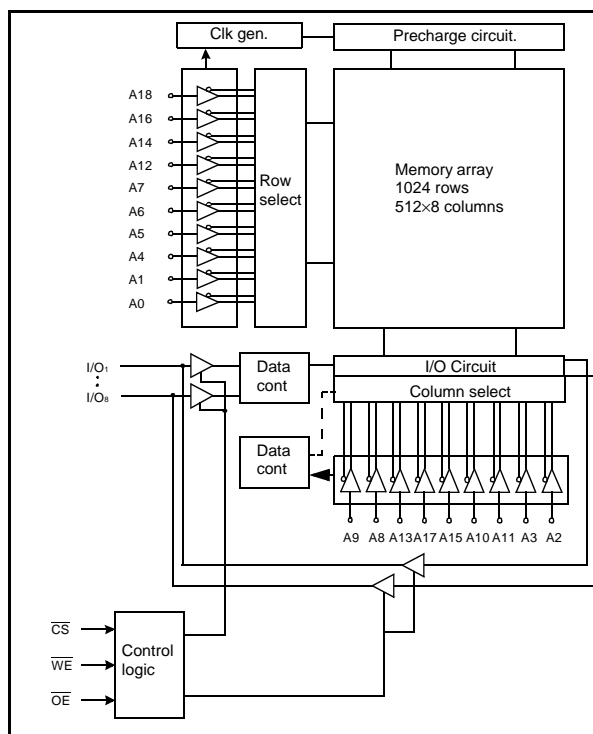

SAMSUNG ELECTRONICS CO., LTD. reserves the right to change products and specifications without notice.

PRODUCT LIST

| Commercial Temperature Products(0~70°C) | | Industrial Temperature Products(-40~85°C) | |
|---|--------------------------|---|--------------------------|
| Part Name | Function | Part Name | Function |
| K6T4008C1B-DL55 | 32-DIP, 55ns, L-pwr | K6T4008C1B-GP55 | 32-SOP, 55ns, L-pwr |
| K6T4008C1B-DB55 | 32-DIP, 55ns, LL-pwr | K6T4008C1B-GF55 | 32-SOP, 55ns, LL-pwr |
| K6T4008C1B-DL70 | 32-DIP, 70ns, L-pwr | K6T4008C1B-GP70 | 32-SOP, 70ns, L-pwr |
| K6T4008C1B-DB70 | 32-DIP, 70ns, LL-pwr | K6T4008C1B-GF70 | 32-SOP, 70ns, LL-pwr |
| K6T4008C1B-GL55 | 32-SOP, 55ns, L-pwr | K6T4008C1B-VF55 | 32-TSOP2-F, 55ns, LL-pwr |
| K6T4008C1B-GB55 | 32-SOP, 55ns, LL-pwr | K6T4008C1B-VF70 | 32-TSOP2-F, 70ns, LL-pwr |
| K6T4008C1B-GL70 | 32-SOP, 70ns, L-pwr | K6T4008C1B-MF55 | 32-TSOP2-R, 55ns, LL-pwr |
| K6T4008C1B-GB70 | 32-SOP, 70ns, LL-pwr | K6T4008C1B-MF70 | 32-TSOP2-R, 70ns, LL-pwr |
| K6T4008C1B-VB55 | 32-TSOP2-F, 55ns, LL-pwr | | |
| K6T4008C1B-VB70 | 32-TSOP2-F, 70ns, LL-pwr | | |
| K6T4008C1B-MB55 | 32-TSOP2-R, 55ns, LL-pwr | | |
| K6T4008C1B-MB70 | 32-TSOP2-R, 70ns, LL-pwr | | |

FUNCTIONAL DESCRIPTION

| \overline{CS} | \overline{OE} | \overline{WE} | I/O Pin | Mode | Power |
|-----------------|-----------------|-----------------|---------|-----------------|---------|
| H | X ¹⁾ | X ¹⁾ | High-Z | Deselected | Standby |
| L | H | H | High-Z | Output disbaled | Active |
| L | L | H | Dout | Read | Active |
| L | X ¹⁾ | L | Din | Write | Active |

1. X means don't care.(Must be in low or high state.)

ABSOLUTE MAXIMUM RATINGS¹⁾

| Item | Symbol | Ratings | Unit | Remark |
|---------------------------------------|-----------------------------------|-------------------------|------|-----------------|
| Voltage on any pin relative to Vss | V _{IN} ,V _{OUT} | -0.5 to 7.0 | V | - |
| Voltage on Vcc supply relative to Vss | V _{CC} | -0.5 to 7.0 | V | - |
| Power Dissipation | P _D | 1.0 | W | - |
| Storage temperature | T _{STG} | -65 to 150 | °C | - |
| Operating Temperature | T _A | 0 to 70 | °C | K6T4008C1B-L/-B |
| | | -40 to 85 | °C | K6T4008C1B-P/-F |
| Soldering temperature and time | T _{SOLDER} | 260°C, 10sec(Lead Only) | - | - |

1. Stresses greater than those listed under "Absolute Maximum Ratings" may cause permanent damage to the device. Functional operation should be restricted to recommended operating condition. Exposure to absolute maximum rating conditions for extended periods may affect reliability.

RECOMMENDED DC OPERATING CONDITIONS¹⁾

| Item | Symbol | Min | Typ | Max | Unit |
|--------------------|-----------------|--------------------|-----|------------------------------------|------|
| Supply voltage | V _{CC} | 4.5 | 5.0 | 5.5 | V |
| Ground | V _{SS} | 0 | 0 | 0 | V |
| Input high voltage | V _{IH} | 2.2 | - | V _{CC} +0.5 ²⁾ | V |
| Input low voltage | V _{IL} | -0.5 ³⁾ | - | 0.8 | V |

Note:

- Commercial Product: T_A=0 to 70°C, otherwise specified
Industrial Product: T_A=-40 to 85°C, otherwise specified
- Overshoot: V_{CC}+3.0V in case of pulse width ≤ 30ns
- Undershoot: -3.0V in case of pulse width ≤ 30ns
- Overshoot and undershoot are sampled, not 100% tested.

CAPACITANCE¹⁾ (f=1MHz, T_A=25°C)

| Item | Symbol | Test Condition | Min | Max | Unit |
|--------------------------|-----------------|---------------------|-----|-----|------|
| Input capacitance | C _{IN} | V _{IN} =0V | - | 8 | pF |
| Input/Output capacitance | C _{IO} | V _{IO} =0V | - | 10 | pF |

- Capacitance is sampled, not 100% tested

DC AND OPERATING CHARACTERISTICS

| Item | Symbol | Test Conditions | Min | Typ | Max | Unit | |
|---------------------------|------------------|--|--------------|-----|-----|------|----|
| Input leakage current | I _{LI} | V _{IN} =V _{SS} to V _{CC} | -1 | - | 1 | μA | |
| Output leakage current | I _{LO} | \overline{CS} =V _{IH} or \overline{OE} =V _{IH} or \overline{WE} =V _{IL} , V _{IO} =V _{SS} to V _{CC} | -1 | - | 1 | μA | |
| Operating power supply | I _{CC} | I _{IO} =0mA, \overline{CS} =V _{IL} , V _{IN} =V _{IL} or V _{IH} , Read | - | 7.5 | 15 | mA | |
| Average operating current | I _{CC1} | Cycle time=1μs, 100% duty, I _{IO} =0mA \overline{CS} ≤0.2V, V _{IN} ≥0.2V or V _{IN} ≥V _{CC} -0.2V | Read | - | 4 | 10 | mA |
| | | | Write | - | 27 | 40 | |
| | I _{CC2} | Cycle time=Min, 100% duty, I _{IO} =0mA, \overline{CS} =V _{IL} , V _{IN} =V _{IH} or V _{IL} | - | 65 | 80 | mA | |
| Output low voltage | V _{OL} | I _{OL} =2.1mA | - | - | 0.4 | V | |
| Output high voltage | V _{OH} | I _{OH} =-1.0mA | 2.4 | - | - | V | |
| Standby Current(TTL) | I _{SB} | \overline{CS} =V _{IH} , Other inputs = V _{IL} or V _{IH} | - | - | 3 | mA | |
| Standby Current(CMOS) | I _{SB1} | \overline{CS} ≥V _{CC} -0.2V, Other inputs=0-V _{CC} | K6T4008C1B-L | - | 2 | 100 | μA |
| | | | K6T4008C1B-B | - | 1 | 20 | μA |
| | | | K6T4008C1B-P | - | 2 | 100 | μA |
| | | | K6T4008C1B-F | - | 1 | 50 | μA |

AC OPERATING CONDITIONS

TEST CONDITIONS (Test Load and Test Input/Output Reference)

Input pulse level: 0.8 to 2.4V
 Input rising and falling time: 5ns
 Input and output reference voltage: 1.5V
 Output load (See right): $C_L=100\text{pF}+1\text{TTL}$
 $C_L=50\text{pF}+1\text{TTL}$

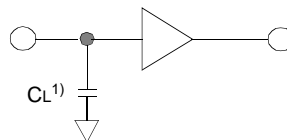

1. Including scope and jig capacitance

AC CHARACTERISTICS ($V_{CC}=4.5\sim 5.5\text{V}$, Commercial product: $T_A=0$ to 70°C , Industrial product: $T_A=-40$ to 85°C)

| Parameter List | | Symbol | Speed Bins | | | | Units |
|----------------|---------------------------------|------------------|------------|-----|------|-----|-------|
| | | | 55*ns | | 70ns | | |
| | | | Min | Max | Min | Max | |
| Read | Read cycle time | t _{RC} | 55 | - | 70 | - | ns |
| | Address access time | t _{AA} | - | 55 | - | 70 | ns |
| | Chip select to output | t _{CO} | - | 55 | - | 70 | ns |
| | Output enable to valid output | t _{OE} | - | 25 | - | 35 | ns |
| | Chip select to low-Z output | t _{LZ} | 10 | - | 10 | - | ns |
| | Output enable to low-Z output | t _{OLZ} | 5 | - | 5 | - | ns |
| | Chip disable to high-Z output | t _{HZ} | 0 | 20 | 0 | 25 | ns |
| | Output disable to high-Z output | t _{OHZ} | 0 | 20 | 0 | 25 | ns |
| | Output hold from address change | t _{OH} | 10 | - | 10 | - | ns |
| Write | Write cycle time | t _{WC} | 55 | - | 70 | - | ns |
| | Chip select to end of write | t _{CW} | 45 | - | 60 | - | ns |
| | Address set-up time | t _{AS} | 0 | - | 0 | - | ns |
| | Address valid to end of write | t _{AW} | 45 | - | 60 | - | ns |
| | Write pulse width | t _{WP} | 40 | - | 50 | - | ns |
| | Write recovery time | t _{WR} | 0 | - | 0 | - | ns |
| | Write to output high-Z | t _{WHZ} | 0 | 20 | 0 | 25 | ns |
| | Data to write time overlap | t _{DW} | 25 | - | 30 | - | ns |
| | Data hold from write time | t _{DH} | 0 | - | 0 | - | ns |
| | End write to output low-Z | t _{OW} | 5 | - | 5 | - | ns |

DATA RETENTION CHARACTERISTICS

| Item | Symbol | Test Condition | Min | Typ | Max | Unit | |
|------------------------------------|-------------------|---|--------------|-----|-----|------|---------------|
| V _{CC} for data retention | V _D R | $\overline{CS} \geq V_{CC}-0.2\text{V}$ | 2.0 | - | 5.5 | V | |
| Data retention current | I _D R | $V_{CC}=3.0\text{V}, \overline{CS} \geq V_{CC}-0.2\text{V}$ | K6T4008C1B-L | - | - | 50 | μA |
| | | | K6T4008C1B-B | - | - | 15 | |
| | | | K6T4008C1B-P | - | - | 50 | |
| | | | K6T4008C1B-F | - | - | 20 | |
| Data retention set-up time | t _{SD} R | See data retention waveform | 0 | - | - | ms | |
| Recovery time | t _R D | | 5 | - | - | | |

TIMING DIAGRAMS

TIMING WAVEFORM OF READ CYCLE(1) (Address Controlled, $\overline{CS}=\overline{OE}=V_{IL}$, $\overline{WE}=V_{IH}$)

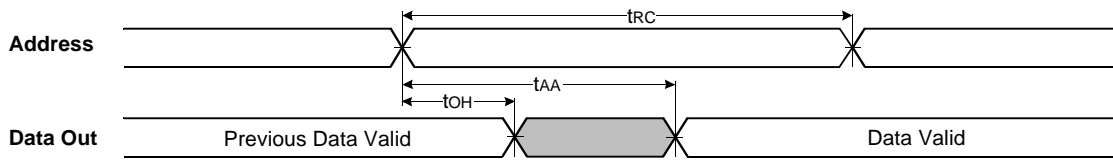

TIMING WAVEFORM OF READ CYCLE(2) ($\overline{WE}=V_{IH}$)

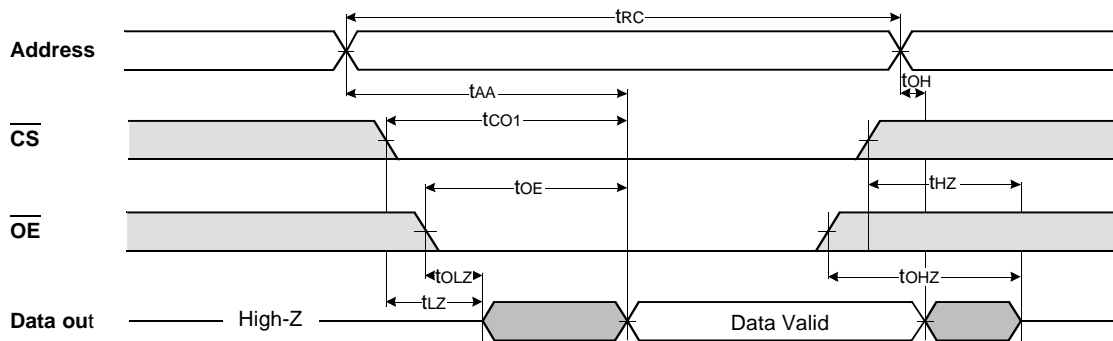

NOTES (READ CYCLE)

1. t_{HZ} and t_{OHZ} are defined as the time at which the outputs achieve the open circuit conditions and are not referenced to output voltage levels.
2. At any given temperature and voltage condition, $t_{HZ}(\text{Max.})$ is less than $t_{LZ}(\text{Min.})$ both for a given device and from device to device interconnection.

TIMING WAVEFORM OF WRITE CYCLE(1) (\overline{WE} Controlled)

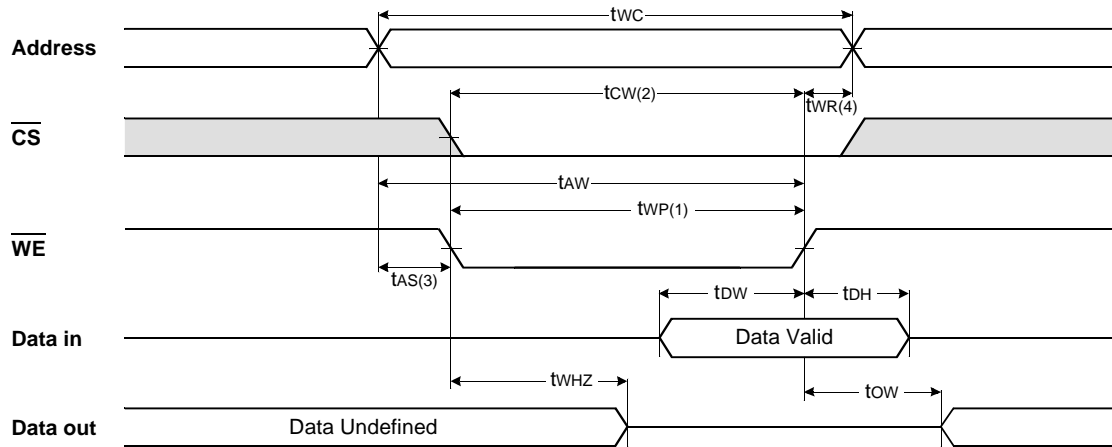

TIMING WAVEFORM OF WRITE CYCLE(2) (\overline{CS} Controlled)

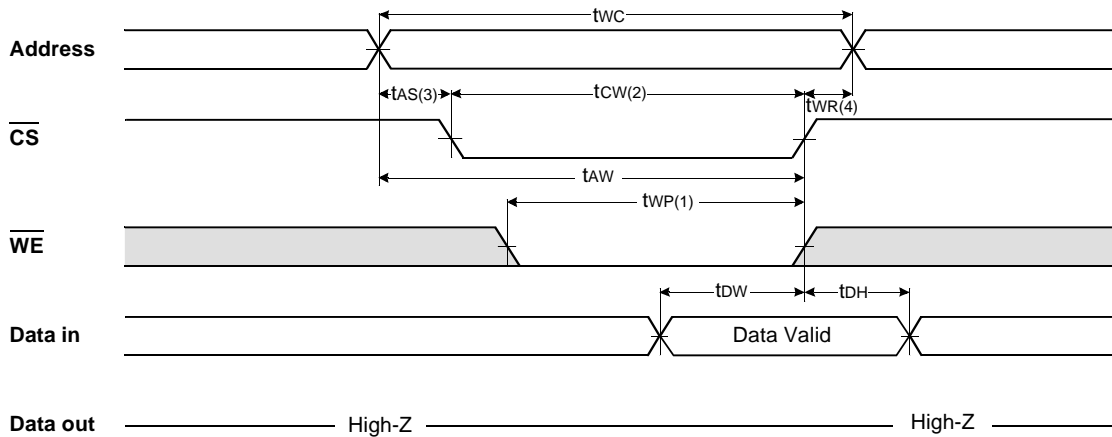

NOTES (WRITE CYCLE)

1. A write occurs during the overlap of a low \overline{CS} and a low \overline{WE} . A write begins at the latest transition among \overline{CS} going Low and \overline{WE} going low : A write end at the earliest transition among \overline{CS} going high and \overline{WE} going high, t_{WP} is measured from the beginning of write to the end of write.
2. t_{CW} is measured from the \overline{CS} going low to the end of write.
3. t_{AS} is measured from the address valid to the beginning of write.
4. t_{WR} is measured from the end of write to the address change. t_{WR} applied in case a write ends as \overline{CS} or \overline{WE} going high.

DATA RETENTION WAVE FORM

\overline{CS} controlled

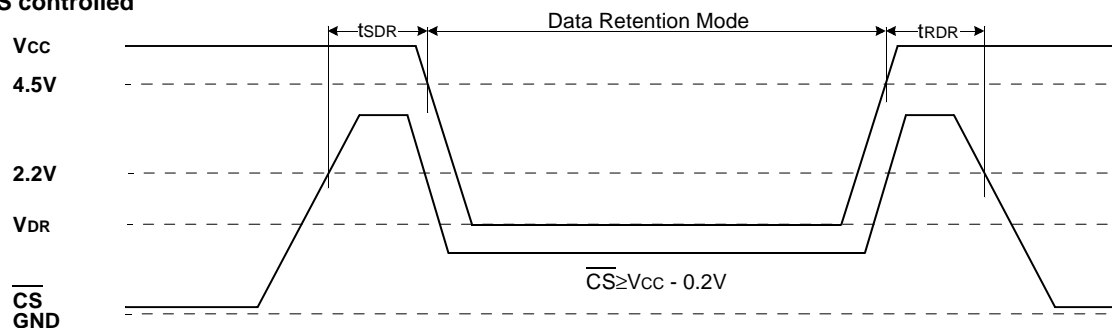

PACKAGE DIMENSIONS

Units: millimeter(Inch)

32 PIN DUAL INLINE PACKAGE (600mil)

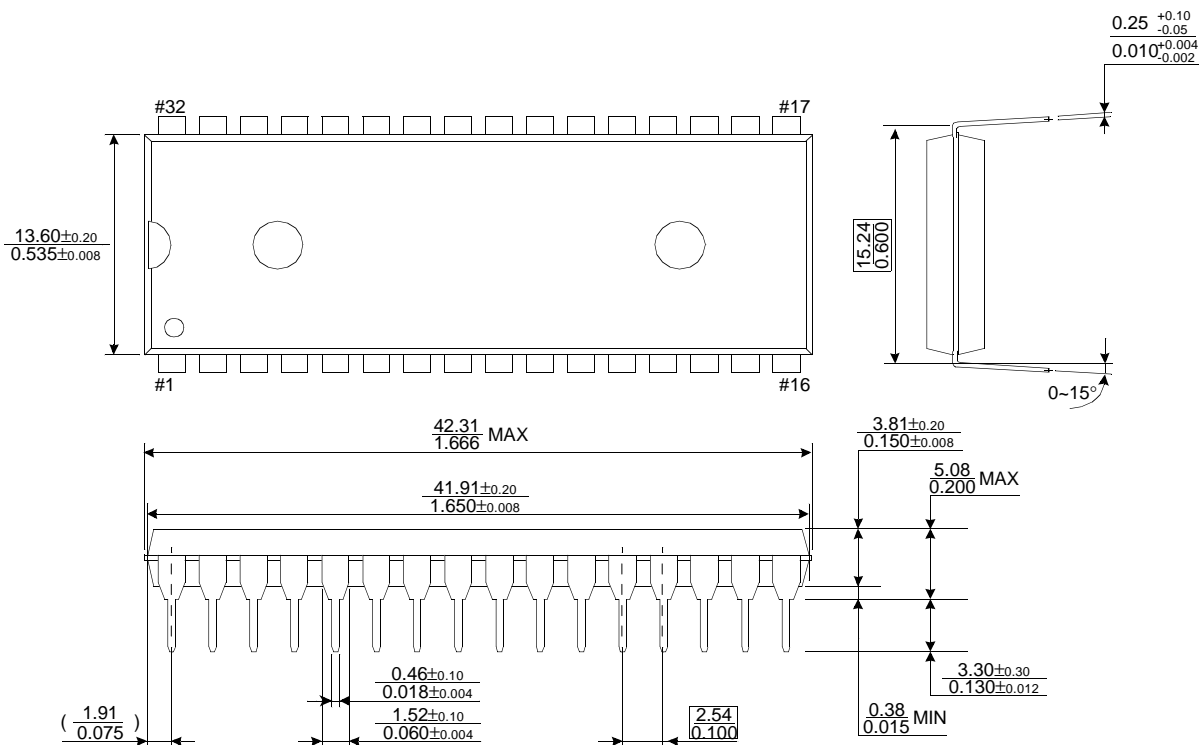

32 PIN PLASTIC SMALL OUTLINE PACKAGE (525mil)

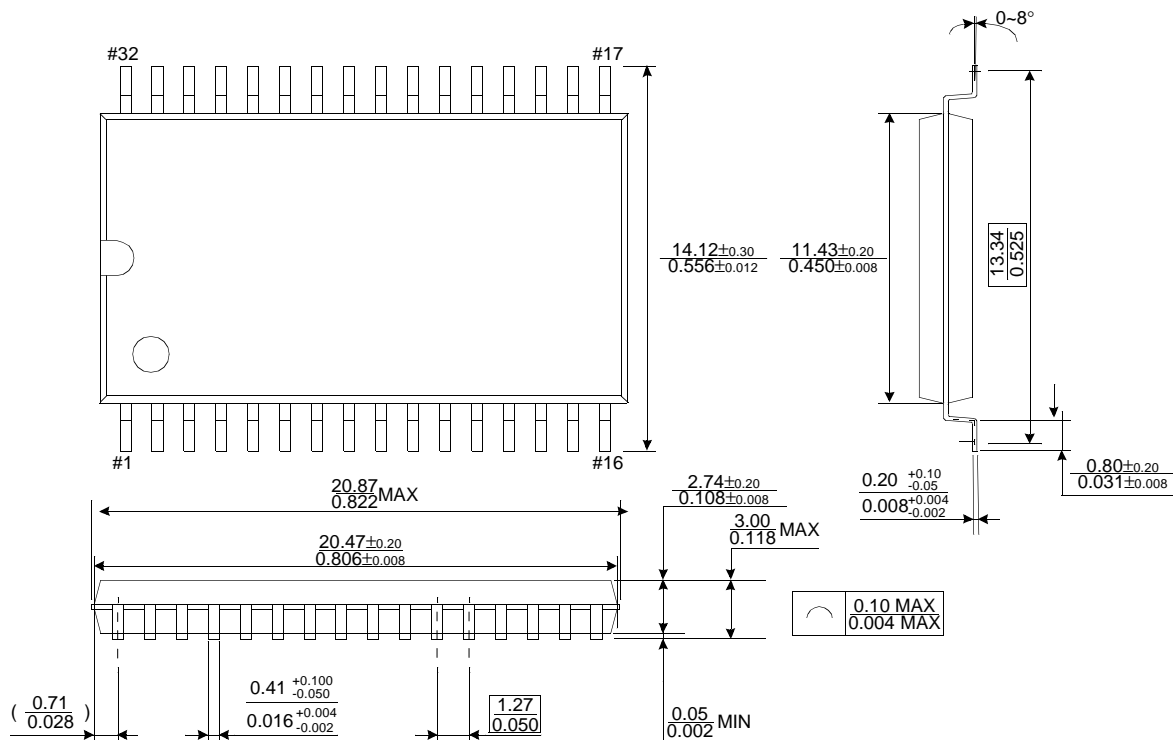

PACKAGE DIMENSIONS

Units: millimeter(Inch)

32 PIN THIN SMALL OUTLINE PACKAGE TYPE II (400F)

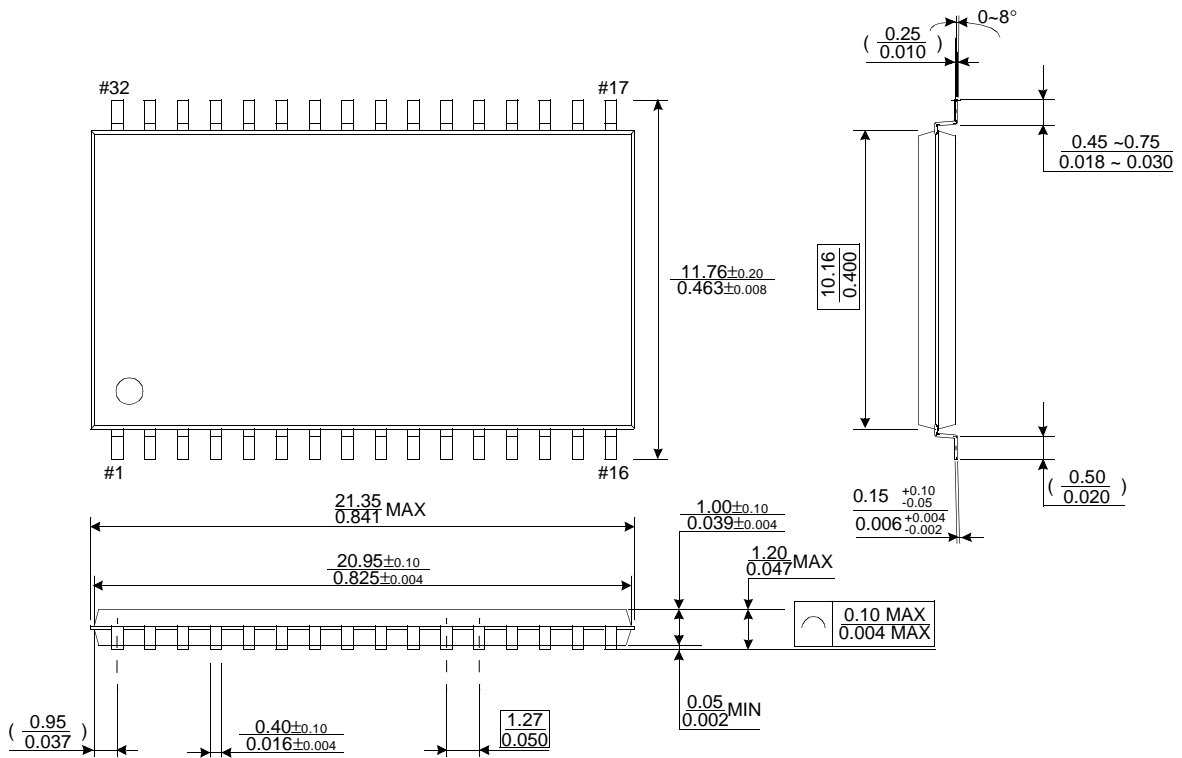

32 PIN THIN SMALL OUTLINE PACKAGE TYPE II (400R)

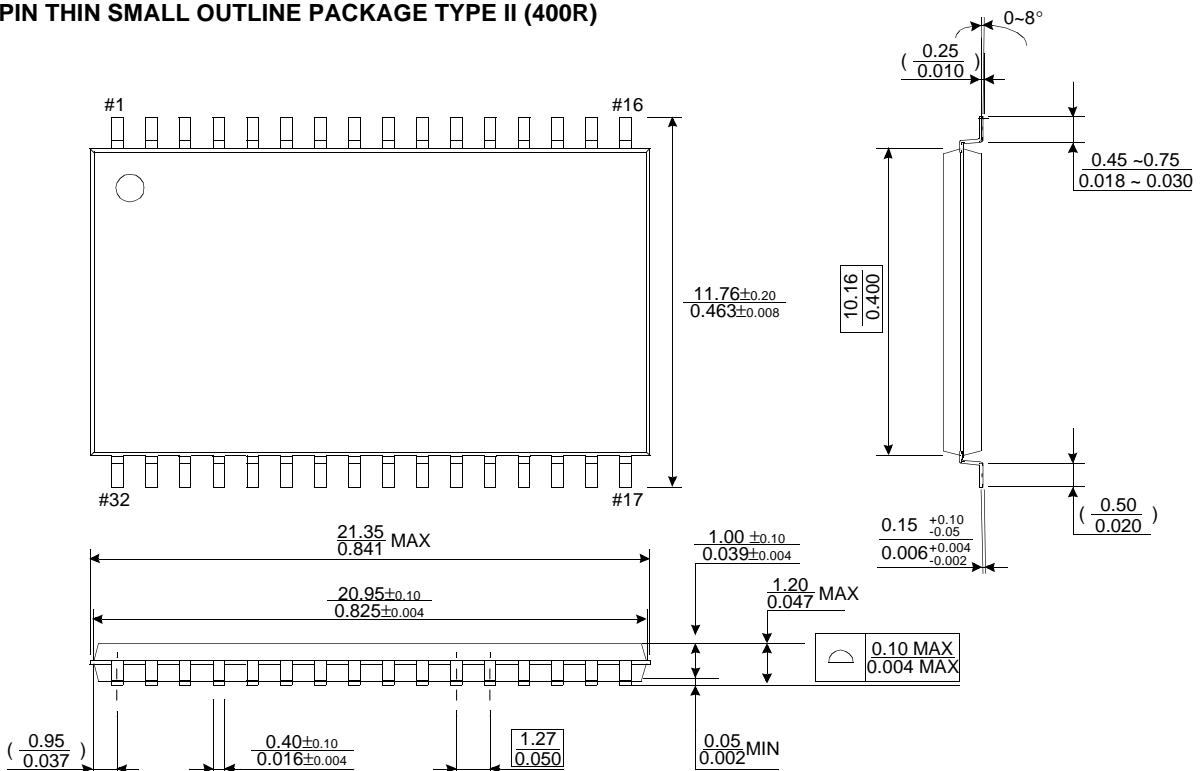

This datasheet has been downloaded from:

www.DatasheetCatalog.com

Datasheets for electronic components.



LittleDiode supplies new, hard to find or obsolete electronic components and semiconductors all over the world.

With over two million different components listed you are sure to find the part you need.

Feel free to visit us today at our online store:

LittleDiode.com

Looking forward to providing you with the best possible service.