

Document Title**1Mx8 bit Low Power and Low Voltage CMOS Static RAM****Revision History**

<u>Revision No.</u>	<u>History</u>	<u>Draft Date</u>	<u>Remark</u>
0.0	Initial draft	October 31, 2002	Preliminary
0.1	Revised - Deleted 44-TSOP2-400R package type. - Added Commercial product.	December 11, 2002	Preliminary
1.0	Finalized - Changed Icc from 10mA to 6mA - Changed Icc1 from 10mA to 7mA - Changed Icc2 from 50mA to 35mA - Changed Isb from 3mA to 0.4mA - Changed Isb1(Commercial) from 40μA to 25μA - Changed Isb1(industrial) from 40μA to 25μA - Changed Isb1(Automotive) from 50μA to 40μA - Changed IdR(Commercial) from 30μA to 15μA - Changed IdR(industrial) from 30μA to 15μA - Changed IdR(Automotive) from 40μA to 30μA	September 16, 2003	Final

The attached datasheets are provided by SAMSUNG Electronics. SAMSUNG Electronics CO., LTD. reserve the right to change the specifications and products. SAMSUNG Electronics will answer to your questions about device. If you have any questions, please contact the SAMSUNG branch offices.

1Mx8 bit Low Power full CMOS Static RAM

FEATURES

- Process Technology: Full CMOS
- Organization: 1M x8
- Power Supply Voltage: 4.5~5.5V
- Low Data Retention Voltage: 2.0V(Min)
- Three state output and TTL Compatible
- Package Type: 44-TSOP2-400F

GENERAL DESCRIPTION

The K6X8008C2B families are fabricated by SAMSUNG's advanced full CMOS process technology. The families support various operating temperature range for user flexibility of system design. The families also support low data retention voltage for battery back-up operation with low data retention current.

PRODUCT FAMILY

Product Family	Operating Temperature	Vcc Range	Speed	Power Dissipation		PKG Type
				Standby (I _{sb1} , Max)	Operating (I _{cc2} , Max)	
K6X8008C2B-B	Commercial(0~70°C)	4.5~5.5V	55 ¹⁾ /70ns	25μA	35mA	44-TSOP2-400F
K6X8008C2B-F	Industrial(-40~85°C)			25μA		
K6X8008C2B-Q	Automotive(-40~125°C)			40μA		

1. The parameter is measured with 50pF test load.

PIN DESCRIPTION

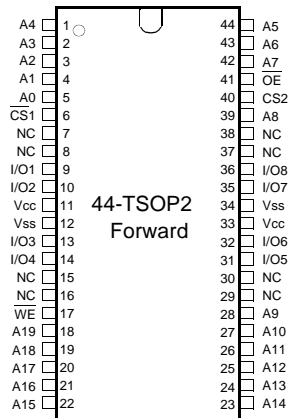

Name	Function	Name	Function
CS ₁ , CS ₂	Chip Select Inputs	Vcc	Power
OE	Output Enable Input	Vss	Ground
WE	Write Enable Input	A ₀ ~A ₁₉	Address Inputs
I/O ₁ ~I/O ₈	Data Inputs/Outputs	NC	No Connect

FUNCTIONAL BLOCK DIAGRAM

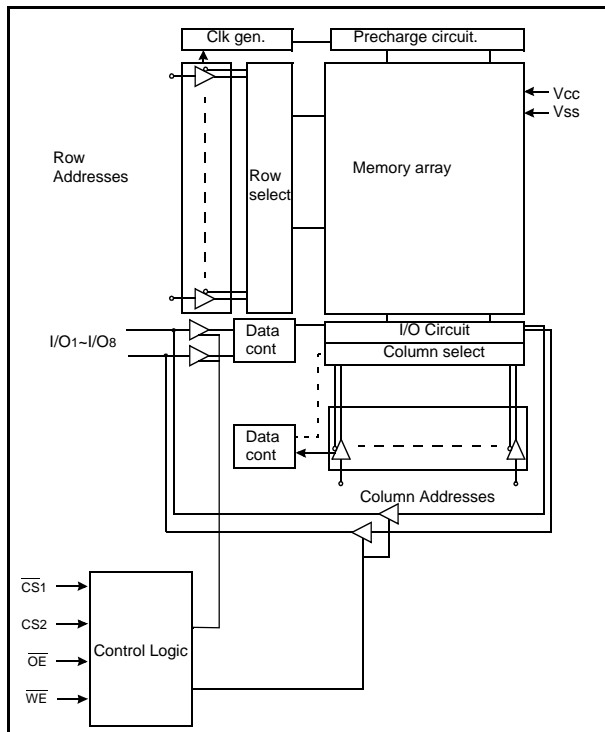

SAMSUNG ELECTRONICS CO., LTD. reserves the right to change products and specifications without notice.

PRODUCT LIST

Commercial Products(0~70°C)		Industrial Products(-40~85°C)		Automotive Products(-40~125°C)	
Part Name	Function	Part Name	Function	Part Name	Function
K6X8008C2B-TB55 K6X8008C2B-TB70	44-TSOP2-F, 55ns, LL 44-TSOP2-F, 70ns, LL	K6X8008C2B-TF55 K6X8008C2B-TF70	44-TSOP2-F, 55ns, LL 44-TSOP2-F, 70ns, LL	K6X8008C2B-TQ55 K6X8008C2B-TQ70	44-TSOP2-F, 55ns, L 44-TSOP2-F, 70ns, L

FUNCTIONAL DESCRIPTION

\overline{CS}_1	CS_2	\overline{OE}	\overline{WE}	I/O1-8	Mode	Power
H	X	X	X	High-Z	Deselected	Standby
X	L	X	X	High-Z	Deselected	Standby
L	H	H	H	High-Z	Output Disabled	Active
L	H	L	H	Dout	Read	Active
L	H	X	L	Din	Write	Active

Note: X means don't care. (Must be low or high state)

ABSOLUTE MAXIMUM RATINGS¹⁾

Item	Symbol	Ratings	Unit	Remark
Voltage on any pin relative to Vss	V _{IN} , V _{OUT}	-0.5 to V _{CC} +0.5V(max.7.0V)	V	-
Voltage on Vcc supply relative to Vss	V _{CC}	-0.3 to 7.0	V	-
Power Dissipation	P _D	1.0	W	-
Storage temperature	T _{STG}	-65 to 150	°C	-
Operating Temperature	T _A	0 to 70	°C	K6X8008C2B-B
		-40 to 85	°C	K6X8008C2B-F
		-40 to 125	°C	K6X8008C2B-Q

1. Stresses greater than those listed under "Absolute Maximum Ratings" may cause permanent damage to the device. Functional operation should be restricted to recommended operating condition. Exposure to absolute maximum rating conditions for extended periods may affect reliability.

RECOMMENDED DC OPERATING CONDITIONS¹⁾

Item	Symbol	Product	Min	Typ	Max	Unit
Supply voltage	V _{CC}	K6X8008C2B Family	4.5	5.0	5.5	V
Ground	V _{SS}	All Family	0	0	0	V
Input high voltage	V _{IH}	K6X8008C2B Family	2.2	-	V _{CC} +0.5 ²⁾	V
Input low voltage	V _{IL}	K6X8008C2B Family	-0.5 ³⁾	-	0.8	V

Note:

- Commercial Product: T_A=0 to 70°C, otherwise specified.
Industrial Product: T_A=-40 to 85°C, otherwise specified.
Automotive Product: T_A=-40 to 125°C, otherwise specified.
- Overshoot: V_{CC}+3.0V in case of pulse width ≤30ns.
- Undershoot: -3.0V in case of pulse width ≤30ns.
- Overshoot and undershoot are sampled, not 100% tested.

CAPACITANCE¹⁾ (f=1MHz, T_A=25°C)

Item	Symbol	Test Condition	Min	Max	Unit
Input capacitance	C _{IN}	V _{IN} =0V	-	8	pF
Input/Output capacitance	C _{IO}	V _{IO} =0V	-	10	pF

- Capacitance is sampled, not 100% tested.

DC AND OPERATING CHARACTERISTICS

Item	Symbol	Test Conditions	Min	Typ	Max	Unit	
Input leakage current	I _{LI}	V _{IN} =V _{SS} to V _{CC}	-1	-	1	μA	
Output leakage current	I _{LO}	$\overline{CS1}=V_{IH}$, $\overline{CS2}=V_{IL}$ or $\overline{OE}=V_{IH}$ or $\overline{WE}=V_{IL}$, V _{IO} =V _{SS} to V _{CC}	-1	-	1	μA	
Operating power supply current	I _{CC}	I _{IO} =0mA, $\overline{CS1}=V_{IL}$, $\overline{CS2}=V_{IH}$, $\overline{WE}=V_{IH}$, V _{IN} =V _{IH} or V _{IL}	-	-	6	mA	
Average operating current	I _{CC1}	Cycle time=1μs, 100%duty, I _{IO} =0mA, $\overline{CS1} \leq 0.2V$, $\overline{CS2} \geq V_{CC}-0.2V$, V _{IN} ≤0.2V or V _{IN} ≥V _{CC} -0.2V	-	-	7	mA	
	I _{CC2}	Cycle time=Min, I _{IO} =0mA, 100% duty, $\overline{CS1}=V_{IL}$, $\overline{CS2}=V_{IH}$, V _{IN} =V _{IL} or V _{IH}	-	-	35	mA	
Output low voltage	V _{OL}	I _{OL} = 2.1mA	-	-	0.4	V	
Output high voltage	V _{OH}	I _{OH} = -1.0mA	2.4	-	-	V	
Standby Current(TTL)	I _{SB}	$\overline{CS1}=V_{IH}$, $\overline{CS2}=V_{IL}$, Other inputs=V _{IH} or V _{IL}	-	-	0.4	mA	
Standby Current(CMOS)	I _{SB1}	Other input =0~V _{CC} , 1) $\overline{CS1} \geq V_{CC}-0.2V$, $\overline{CS2} \geq V_{CC}-0.2V$ ($\overline{CS1}$ controlled) or 2) $0V \leq \overline{CS2} \leq 0.2V$ ($\overline{CS2}$ controlled)	K6X8008C2B-B	-	-	25	μA
			K6X8008C2B-F	-	-	25	
			K6X8008C2B-Q	-	-	40	

AC OPERATING CONDITIONS

TEST CONDITIONS (Test Load and Input/Output Reference)

Input pulse level: 0.8 to 2.4V
 Input rising and falling time: 5ns
 Input and output reference voltage: 1.5V
 Output load(see right): $C_L=100pF+1TTL$
 $C_L=50pF+1TTL$

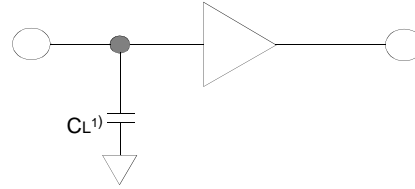

1. Including scope and jig capacitance

AC CHARACTERISTICS

($V_{CC}=4.5\sim 5.5V$, Commercial product: $T_A=0$ to $70^\circ C$, Industrial product: $T_A=-40$ to $85^\circ C$, Automotive product: $T_A=-40$ to $125^\circ C$)

Parameter List	Symbol	Speed Bins				Units	
		55ns		70ns			
		Min	Max	Min	Max		
Read	Read Cycle Time	tRC	55	-	70	-	ns
	Address Access Time	tAA	-	55	-	70	ns
	Chip Select to Output	tCO	-	55	-	70	ns
	Output Enable to Valid Output	tOE	-	25	-	35	ns
	Chip Select to Low-Z Output	tLZ	10	-	10	-	ns
	Output Enable to Low-Z Output	tOLZ	5	-	5	-	ns
	Chip Disable to High-Z Output	tHZ	0	20	0	25	ns
	Output Disable to High-Z Output	tOHZ	0	20	0	25	ns
	Output Hold from Address Change	tOH	10	-	10	-	ns
Write	Write Cycle Time	tWC	55	-	70	-	ns
	Chip Select to End of Write	tCW	45	-	60	-	ns
	Address Set-up Time	tAS	0	-	0	-	ns
	Address Valid to End of Write	tAW	45	-	60	-	ns
	Write Pulse Width	tWP	40	-	50	-	ns
	Write Recovery Time	tWR	0	-	0	-	ns
	Write to Output High-Z	tWHZ	0	20	0	20	ns
	Data to Write Time Overlap	tDW	25	-	30	-	ns
	Data Hold from Write Time	tDH	0	-	0	-	ns
End Write to Output Low-Z	tOW	5	-	5	-	ns	

DATA RETENTION CHARACTERISTICS

Item	Symbol	Test Condition	Min	Typ	Max	Unit
Vcc for data retention	VDR	$\overline{CS}_1 \geq V_{CC}-0.2V^{(1)}$	2.0	-	5.5	V
Data retention current	IDR	$V_{CC}=3.0V, \overline{CS}_1 \geq V_{CC}-0.2V^{(1)}$	-	-	15	μA
					15	
					30	
Data retention set-up time	tSDR	See data retention waveform	0	-	-	ms
Recovery time	trDR		5	-	-	

1. $\overline{CS}_1 \geq V_{CC}-0.2V, CS_2 \geq V_{CC}-0.2V$ (\overline{CS}_1 controlled) or $CS_2 \geq V_{CC}-0.2V$ (CS_2 controlled).

TIMING WAVEFORM OF WRITE CYCLE(1) (\overline{WE} Controlled)

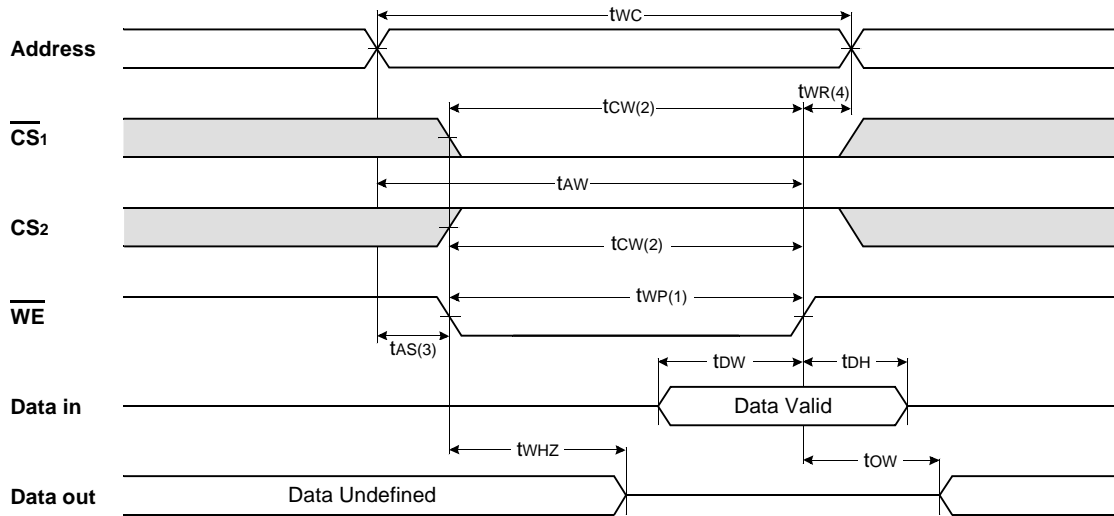

TIMING WAVEFORM OF WRITE CYCLE(2) ($\overline{CS1}$ Controlled)

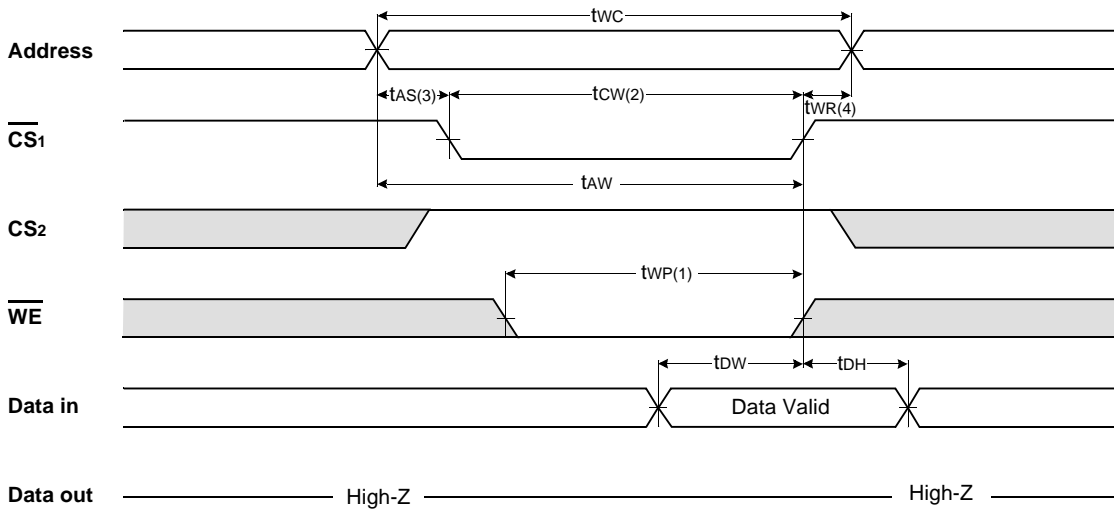

TIMING WAVEFORM OF WRITE CYCLE(3) (CS₂ Controlled)

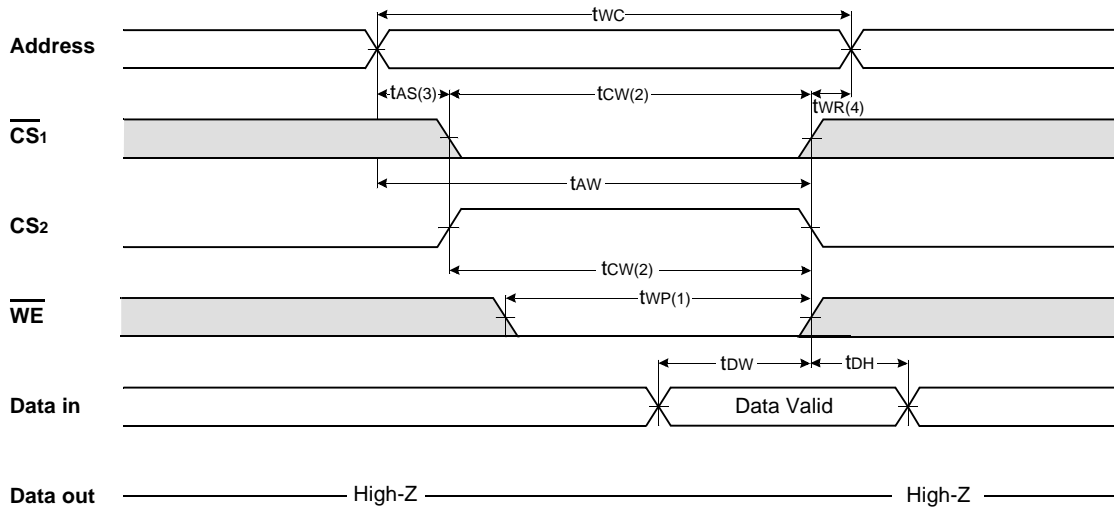

NOTES (WRITE CYCLE)

1. A write occurs during the overlap of a low \overline{CS}_1 , a high CS_2 and a low \overline{WE} . A write begins at the latest transition among \overline{CS}_1 goes low, CS_2 going high and \overline{WE} going low : A write ends at the earliest transition among CS_1 going high, CS_2 going low and \overline{WE} going high, t_{WP} is measured from the beginning of write to the end of write.
2. t_{CW} is measured from the \overline{CS}_1 going low or CS_2 going high to the end of write.
3. t_{AS} is measured from the address valid to the beginning of write.
4. t_{WR} is measured from the end of write to the address change. t_{WR} applied in case a write ends as \overline{CS}_1 or \overline{WE} going high t_{WR2} applied in case a write ends as CS_2 going to low.

DATA RETENTION WAVE FORM

\overline{CS}_1 controlled

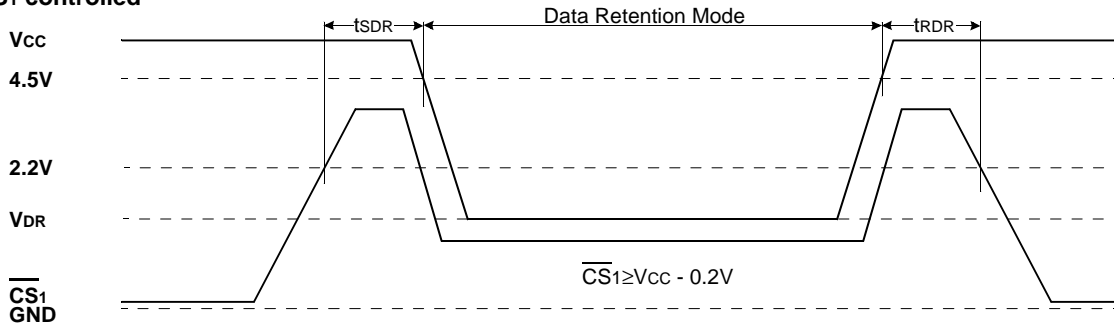

CS_2 controlled

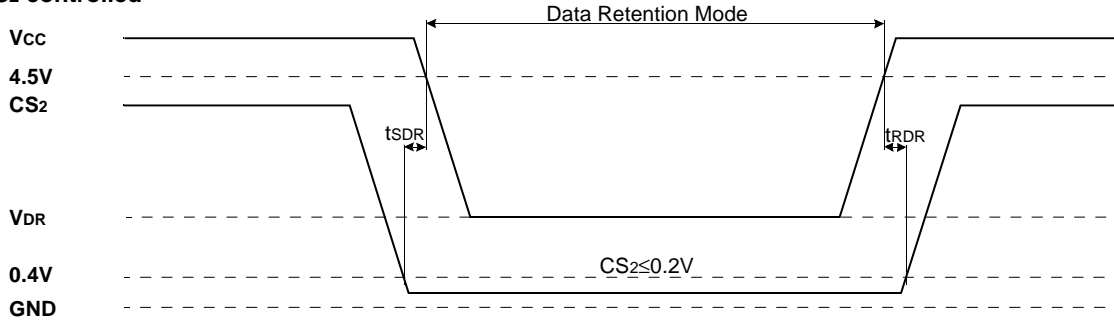

PACKAGE DIMENSIONS

Unit: millimeters(inches)

44 PIN THIN SMALL OUTLINE PACKAGE TYPE II (400F)

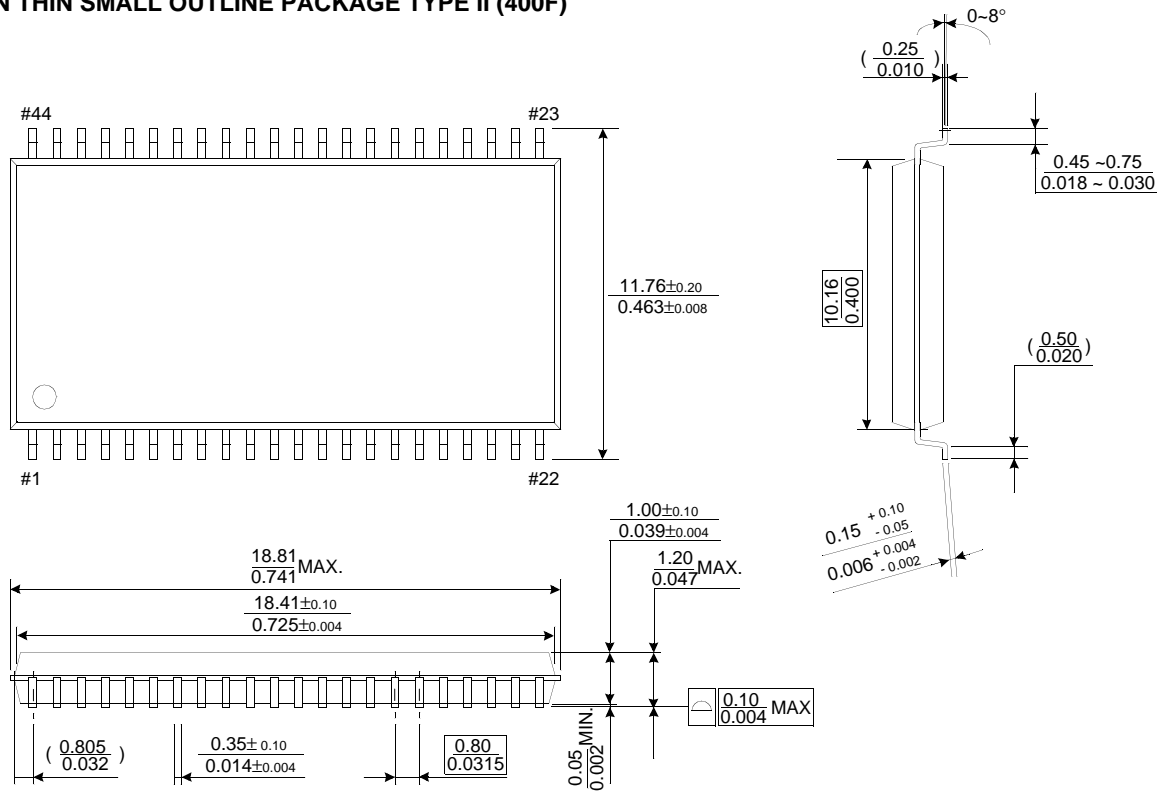

This datasheet has been downloaded from:

www.DatasheetCatalog.com

Datasheets for electronic components.



LittleDiode supplies new, hard to find or obsolete electronic components and semiconductors all over the world.

With over two million different components listed you are sure to find the part you need.

Feel free to visit us today at our online store:

LittleDiode.com

Looking forward to providing you with the best possible service.