

## Optocoupler, Phototransistor Output

### Features

- Endstackable to 2.54 mm (0.1") spacing
- DC isolation test voltage  $V_{ISO} = 5000 V_{RMS}$
- Low coupling capacitance of typical 0.3 pF
- **C**urrent **T**ransfer **R**atio (CTR) selected into groups
- Low temperature coefficient of CTR
- Wide ambient temperature range
- Available in single, dual and quad channel packages
- Lead-free component
- Component in accordance to RoHS 2002/95/EC and WEEE 2002/96/EC

### Agency Approvals

- UL1577, File No. E76222 System Code U, Double Protection
- CSA 93751

### Applications

Programmable logic controllers, modems, answering machines, general applications

### Description

In the K817P/ K827PH/ K847PH parts each channel consist of a phototransistor optically coupled to a gallium arsenide infrared-emitting diode in a 4-pin (single); 8 pin (dual); 16-pin (quad) plastic dual inline package.

The elements are mounted on one leadframe providing a fixed distance between input and output for highest safety requirements.

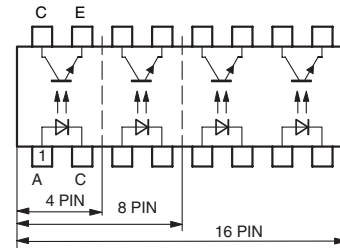
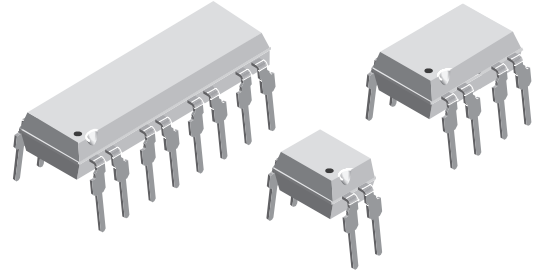

17203\_1



### Order Information

Part	Remarks
K817P	CTR 50 - 600 %, DIP-4
K817P1	CTR 40 - 80 %, DIP-4
K817P2	CTR 63 - 125 %, DIP-4
K817P3	CTR 100 - 200 %, DIP-4
K817P4	CTR 160 - 320 %, DIP-4
K817P5	CTR 50 - 150 %, DIP-4
K817P6	CTR 100 - 300 %, DIP-4
K817P7	CTR 80 - 160 %, DIP-4
K817P8	CTR 130 - 260 %, DIP-4
K817P9	CTR 200 - 400 %, DIP-4
K827PH	CTR 50 - 600 %, DIP-8
K847PH	CTR 50 - 600 %, DIP-16

## Absolute Maximum Ratings

$T_{amb} = 25\text{ }^{\circ}\text{C}$ , unless otherwise specified

Stresses in excess of the absolute Maximum Ratings can cause permanent damage to the device. Functional operation of the device is not implied at these or any other conditions in excess of those given in the operational sections of this document. Exposure to absolute Maximum Rating for extended periods of the time can adversely affect reliability.

### Input

Parameter	Test condition	Symbol	Value	Unit
Reverse voltage		$V_R$	6	V
Forward current		$I_F$	60	mA
Forward surge current	$t_p \leq 10\text{ }\mu\text{s}$	$I_{FSM}$	1.5	A
Power dissipation		$P_{diss}$	100	mW
Junction temperature		$T_j$	125	$^{\circ}\text{C}$

### Output

Parameter	Test condition	Symbol	Value	Unit
Collector emitter voltage		$V_{CEO}$	70	V
Emitter collector voltage		$V_{ECO}$	7	V
Collector current		$I_C$	50	mA
Collector peak current	$t_p/T = 0.5, t_p \leq 10\text{ ms}$	$I_{CM}$	100	mA
Power dissipation		$P_{diss}$	150	mW
Junction temperature		$T_j$	125	$^{\circ}\text{C}$

### Coupler

Parameter	Test condition	Symbol	Value	Unit
AC isolation test voltage (RMS)	$t = 1\text{ min}$	$V_{ISO}^{1)}$	5000	$V_{RMS}$
Total power dissipation		$P_{tot}$	250	mW
Operating ambient temperature range		$T_{amb}$	- 40 to + 100	$^{\circ}\text{C}$
Storage temperature range		$T_{stg}$	- 55 to + 125	$^{\circ}\text{C}$
Soldering temperature	2 mm from case, $t \leq 10\text{ s}$	$T_{sld}$	260	$^{\circ}\text{C}$

<sup>1)</sup> Related to standard climate 23/50 DIN 50014

## Electrical Characteristics

$T_{amb} = 25\text{ }^{\circ}\text{C}$ , unless otherwise specified

Minimum and maximum values are testing requirements. Typical values are characteristics of the device and are the result of engineering evaluation. Typical values are for information only and are not part of the testing requirements.

### Input

Parameter	Test condition	Symbol	Min	Typ.	Max	Unit
Forward voltage	$I_F = 50\text{ mA}$	$V_F$		1.25	1.6	V
Junction capacitance	$V_R = 0\text{ V}, f = 1\text{ MHz}$	$C_j$		50		pF



## Output

Parameter	Test condition	Symbol	Min	Typ.	Max	Unit
Collector emitter voltage	$I_C = 100 \mu\text{A}$	$V_{CEO}$	70			V
Emitter collector voltage	$I_E = 100 \mu\text{A}$	$V_{ECO}$	7			V
Collector dark current	$V_{CE} = 20 \text{ V}, I_F = 0, E = 0$	$I_{CEO}$			100	nA

## Coupler

Parameter	Test condition	Symbol	Min	Typ.	Max	Unit
Collector emitter saturation voltage	$I_F = 10 \text{ mA}, I_C = 1 \text{ mA}$	$V_{CEsat}$			0.3	V
Cut-off frequency	$I_F = 10 \text{ mA}, V_{CE} = 5 \text{ V}, R_L = 100 \Omega$	$f_c$		100		kHz
Coupling capacitance	$f = 1 \text{ MHz}$	$C_k$		0.3		pF

## Current Transfer Ratio

Parameter	Test condition	Part	Symbol	Min	Typ.	Max	Unit
$I_C/I_F$	$V_{CE} = 5 \text{ V}, I_F = 5 \text{ mA}$	K817P	CTR	50		600	%
		K827PH	CTR	50		600	%
		K847PH	CTR	50		600	%
	$V_{CE} = 5 \text{ V}, I_F = 10 \text{ mA}$	K817P1	CTR	40		80	%
		K817P2	CTR	63		125	%
		K817P3	CTR	100		200	%
		K817P4	CTR	160		320	%
	$V_{CE} = 5 \text{ V}, I_F = 5 \text{ mA}$	K817P5	CTR	50		150	%
		K817P6	CTR	100		300	%
		K817P7	CTR	80		160	%
		K817P8	CTR	130		260	%
		K817P9	CTR	200		400	%

### Switching Characteristics

Parameter	Test condition	Symbol	Min	Typ.	Max	Unit
Delay time	$V_S = 5\text{ V}$ , $I_C = 2\text{ mA}$ , $R_L = 100\ \Omega$ (see figure 1)	$t_d$		3.0		$\mu\text{s}$
Rise time	$V_S = 5\text{ V}$ , $I_C = 2\text{ mA}$ , $R_L = 100\ \Omega$ (see figure 1)	$t_r$		3.0		$\mu\text{s}$
Fall time	$V_S = 5\text{ V}$ , $I_C = 2\text{ mA}$ , $R_L = 100\ \Omega$ (see figure 1)	$t_f$		4.7		$\mu\text{s}$
Storage time	$V_S = 5\text{ V}$ , $I_C = 2\text{ mA}$ , $R_L = 100\ \Omega$ (see figure 1)	$t_s$		0.3		$\mu\text{s}$
Turn-on time	$V_S = 5\text{ V}$ , $I_C = 2\text{ mA}$ , $R_L = 100\ \Omega$ (see figure 1)	$t_{on}$		6.0		$\mu\text{s}$
Turn-off time	$V_S = 5\text{ V}$ , $I_C = 2\text{ mA}$ , $R_L = 100\ \Omega$ (see figure 1)	$t_{off}$		5.0		$\mu\text{s}$
Turn-on time	$V_S = 5\text{ V}$ , $I_F = 10\text{ mA}$ , $R_L = 1\text{ k}\Omega$ (see figure 2)	$t_{on}$		9.0		$\mu\text{s}$
Turn-off time	$V_S = 5\text{ V}$ , $I_F = 10\text{ mA}$ , $R_L = 1\text{ k}\Omega$ (see figure 2)	$t_{off}$		18.0		$\mu\text{s}$

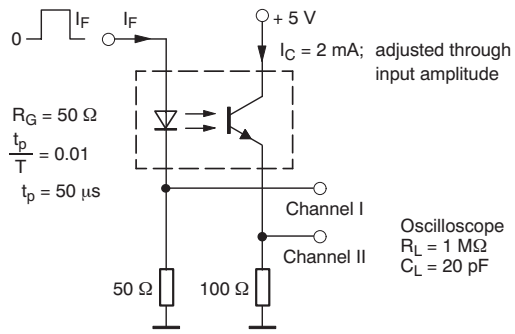

95 10804

Figure 1. Test circuit, non-saturated operation

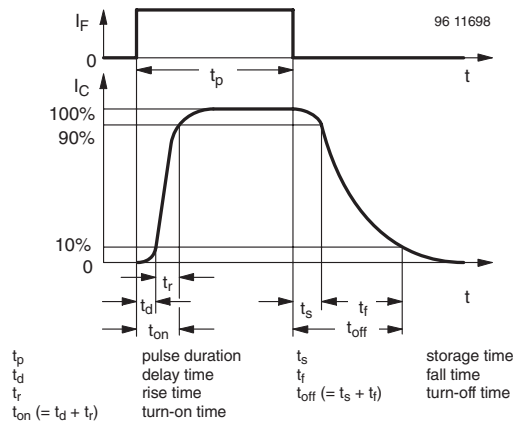
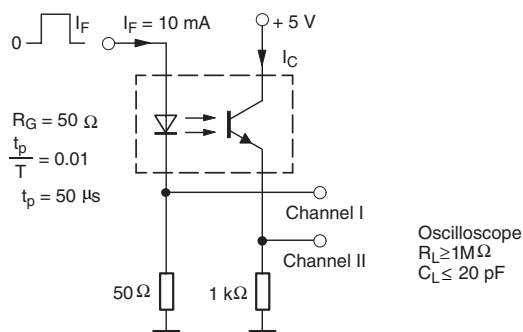

Figure 3. Switching Times



95 10843

Figure 2. Test circuit, saturated operation

## Typical Characteristics ( $T_{amb} = 25\text{ }^{\circ}\text{C}$ unless otherwise specified)

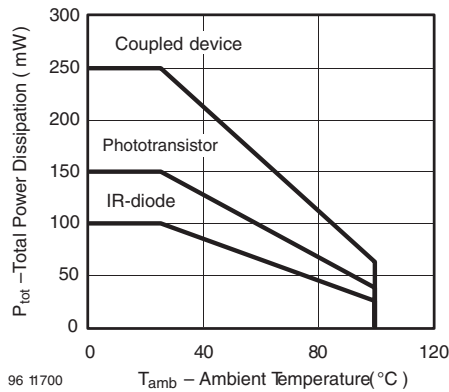

Figure 4. Total Power Dissipation vs. Ambient Temperature

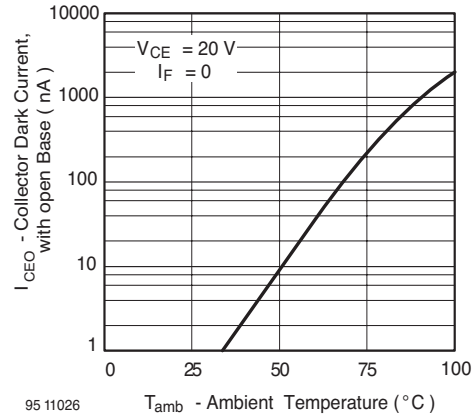

Figure 7. Collector Dark Current vs. Ambient Temperature

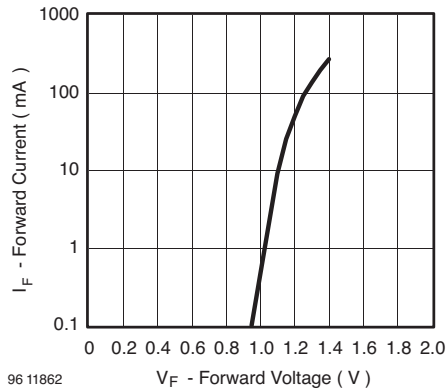

Figure 5. Forward Current vs. Forward Voltage

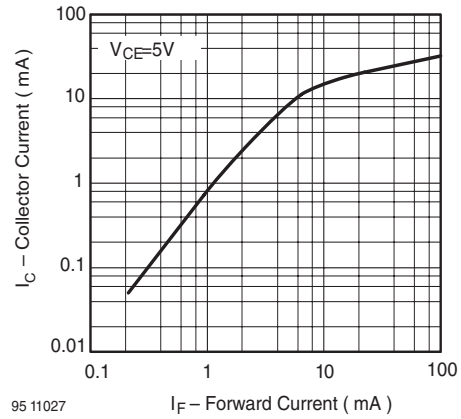

Figure 8. Collector Current vs. Forward Current

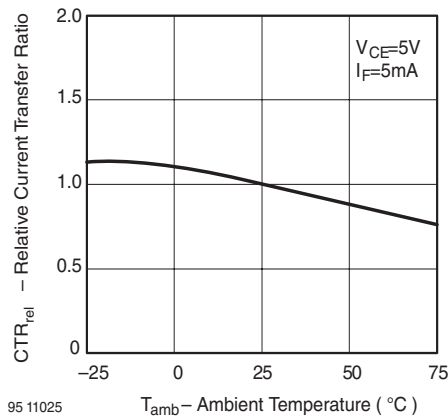

Figure 6. Relative Current Transfer Ratio vs. Ambient Temperature

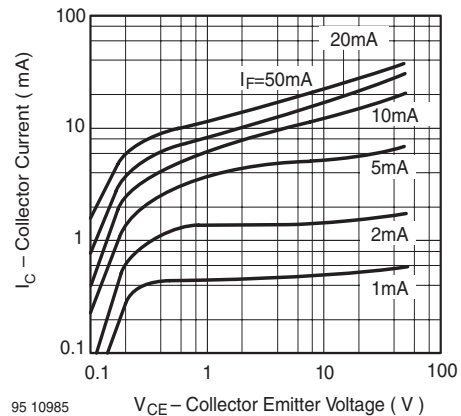
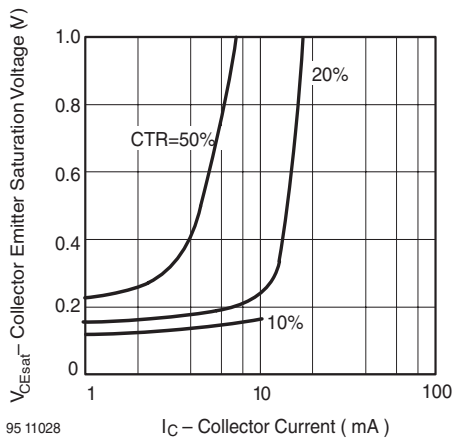
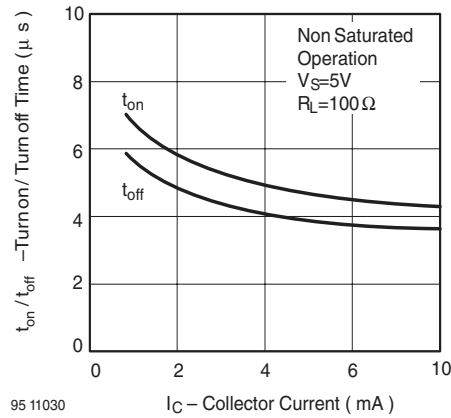

Figure 9. Collector Current vs. Collector Emitter Voltage



95 11028

Figure 10. Collector Emitter Saturation Voltage vs. Collector Current



95 11030

Figure 13. Turn on / off Time vs. Collector Current

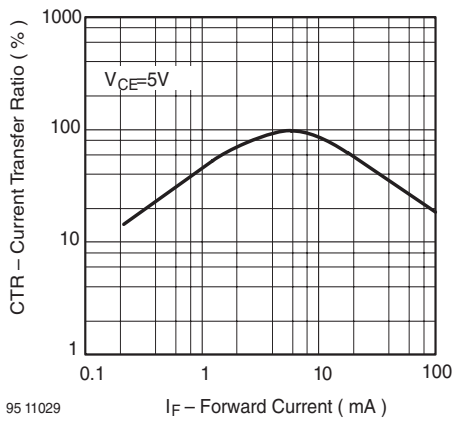

95 11029

Figure 11. Current Transfer Ratio vs. Forward Current

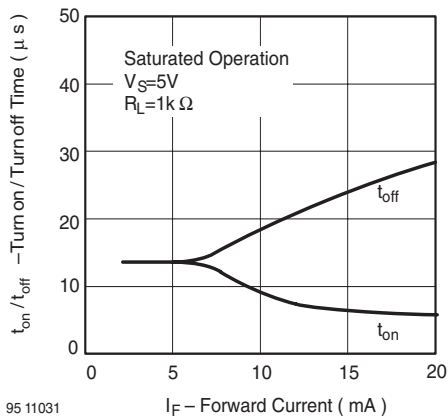

95 11031

Figure 12. Turn on / off Time vs. Forward Current

## Package Dimensions in mm

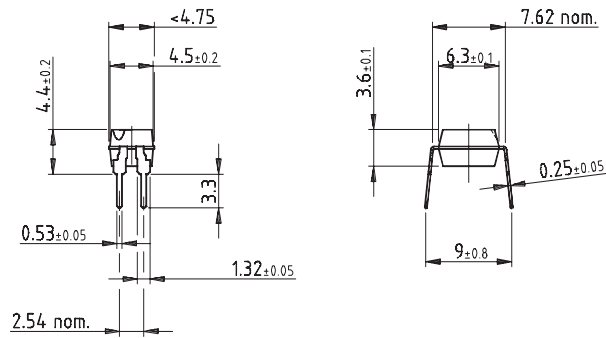

E.g:  
special Features: endstackable  
to 2.54mm (.100") spacing

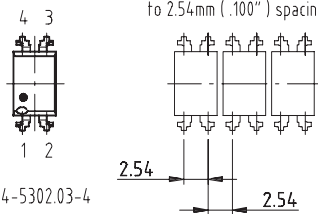

weight : ca 0.25g  
creepage distance : > 6mm  
air path : > 6mm  
after mounting on PC board

Drawing-No.: 6.544-5302.03-4  
Issue: 5; 20.03.02

technical drawings  
according to DIN  
specifications

14789

## Package Dimensions in mm

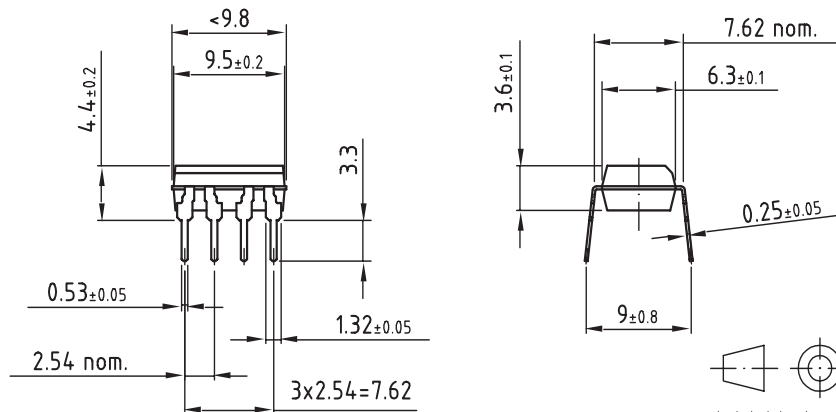

weight : ca 0.55g  
creepage distance : > 6mm  
air path : > 6mm  
after mounting on PC board

technical drawings  
according to DIN  
specifications

Drawing-No.: 6.544-5302.02-4  
Issue: 4; 02.06.99

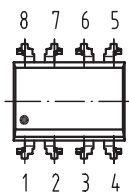

14784

# K817P/ K827PH/ K847PH



Vishay Semiconductors

## Package Dimensions in mm

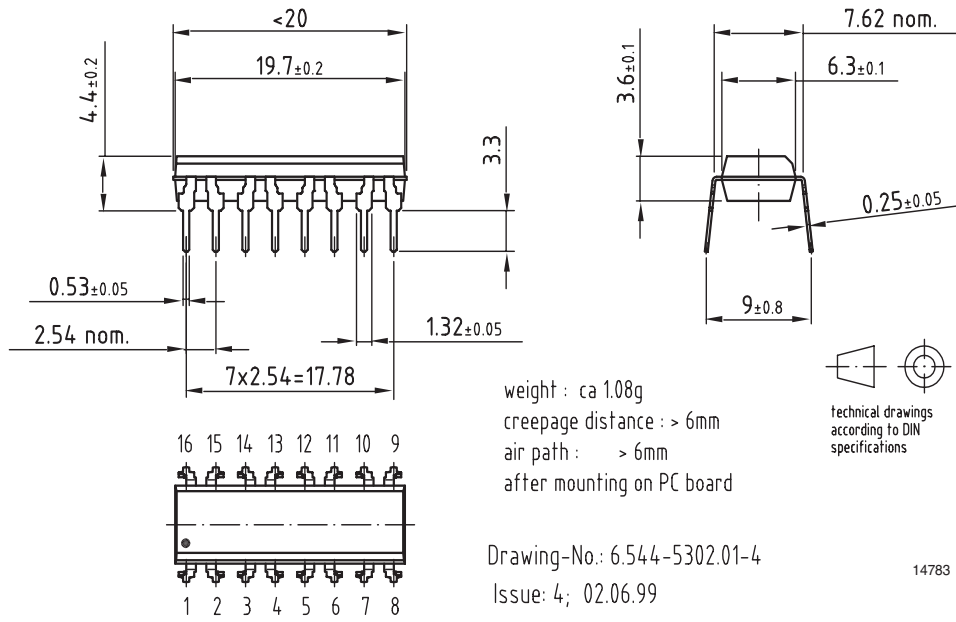



## Ozone Depleting Substances Policy Statement

It is the policy of Vishay Semiconductor GmbH to

1. Meet all present and future national and international statutory requirements.
2. Regularly and continuously improve the performance of our products, processes, distribution and operating systems with respect to their impact on the health and safety of our employees and the public, as well as their impact on the environment.

It is particular concern to control or eliminate releases of those substances into the atmosphere which are known as ozone depleting substances (ODSs).

The Montreal Protocol (1987) and its London Amendments (1990) intend to severely restrict the use of ODSs and forbid their use within the next ten years. Various national and international initiatives are pressing for an earlier ban on these substances.

Vishay Semiconductor GmbH has been able to use its policy of continuous improvements to eliminate the use of ODSs listed in the following documents.

1. Annex A, B and list of transitional substances of the Montreal Protocol and the London Amendments respectively
2. Class I and II ozone depleting substances in the Clean Air Act Amendments of 1990 by the Environmental Protection Agency (EPA) in the USA
3. Council Decision 88/540/EEC and 91/690/EEC Annex A, B and C (transitional substances) respectively.

Vishay Semiconductor GmbH can certify that our semiconductors are not manufactured with ozone depleting substances and do not contain such substances.

We reserve the right to make changes to improve technical design and may do so without further notice.

Parameters can vary in different applications. All operating parameters must be validated for each customer application by the customer. Should the buyer use Vishay Semiconductors products for any unintended or unauthorized application, the buyer shall indemnify Vishay Semiconductors against all claims, costs, damages, and expenses, arising out of, directly or indirectly, any claim of personal damage, injury or death associated with such unintended or unauthorized use.

Vishay Semiconductor GmbH, P.O.B. 3535, D-74025 Heilbronn, Germany  
Telephone: 49 (0)7131 67 2831, Fax number: 49 (0)7131 67 2423



LittleDiode supplies new, hard to find or obsolete electronic components and semiconductors all over the world.

With over two million different components listed you are sure to find the part you need.

Feel free to visit us today at our online store:

[LittleDiode.com](http://LittleDiode.com)

Looking forward to providing you with the best possible service.