



5V 1M×16 CMOS DRAM (EDO)

Features

- Organization: 1,048,576 words × 16 bits
- High speed
  - 45/50/60 ns  $\overline{\text{RAS}}$  access time
  - 20/20/25 ns hyper page cycle time
  - 10/12/15 ns  $\overline{\text{CAS}}$  access time
- Low power consumption
  - Active: 740 mW max (AS4C1M16E5-60)
  - Standby: 5.5 mW max, CMOS DQ
- Extended data out
- 1024 refresh cycles, 16 ms refresh interval
  - $\overline{\text{RAS}}$ -only or  $\overline{\text{CAS}}$ -before- $\overline{\text{RAS}}$  refresh Read-modify-write
- TTL-compatible, three-state DQ
- JEDEC standard package and pinout
  - 400 mil, 42-pin SOJ
  - 400 mil, 44/50-pin TSOP II
- 5V power supply (AS4C1M16E5)
- 3V power supply (AS4LC1M16E5)
- Industrial and commercial temperature available

Pin arrangement

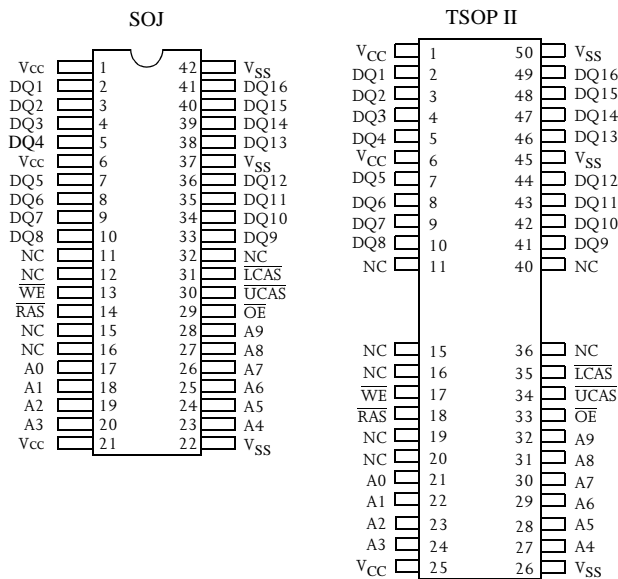

Pin designation

Pin(s)	Description
A0 to A9	Address inputs
$\overline{\text{RAS}}$	Row address strobe
DQ1 to DQ16	Input/output
$\overline{\text{OE}}$	Output enable
$\overline{\text{WE}}$	Write enable
$\overline{\text{UCAS}}$	Column address strobe, upper byte
$\overline{\text{LCAS}}$	Column address strobe, lower byte
$V_{\text{CC}}$	Power
$V_{\text{SS}}$	Ground

Selection guide

	Symbol	-45	-50	-60	Unit
Maximum $\overline{\text{RAS}}$ access time	$t_{\text{RAC}}$	45	50	60	ns
Maximum column address access time	$t_{\text{AA}}$	23	25	30	ns
Maximum $\overline{\text{CAS}}$ access time	$t_{\text{CAC}}$	10	12	15	ns
Maximum output enable ( $\overline{\text{OE}}$ ) access time	$t_{\text{OEA}}$	12	13	15	ns
Minimum read or write cycle time	$t_{\text{RC}}$	75	80	100	ns
Minimum hyper page mode cycle time	$t_{\text{HPC}}$	20	20	25	ns
Maximum operating current	$I_{\text{CC1}}$	155	145	135	mA
Maximum CMOS standby current	$I_{\text{CC5}}$	1.0	1.0	1.0	mA



## Functional description

The AS4C1M16E5 is a high performance 16-megabit CMOS Dynamic Random Access Memory (DRAM) organized as 1,048,576 words  $\times$  16 bits. The device is fabricated using advanced CMOS technology and innovative design techniques resulting in high speed, extremely low power and wide operating margins at component and system levels. The Alliance 16Mb DRAM family is optimized for use as main memory in personal and portable PCs, workstations, and multimedia and router switch applications.

The AS4C1M16E5 features hyper page mode operation where read and write operations within a single row (or page) can be executed at very high speed by toggling column addresses within that row. Row and column addresses are alternately latched into input buffers using the falling edge of  $\overline{\text{RAS}}$  and  $\overline{\text{xCAS}}$  inputs, respectively. Also,  $\overline{\text{RAS}}$  is used to make the column address latch transparent, enabling application of column addresses prior to  $\overline{\text{xCAS}}$  assertion. The AS4C1M16E5 provides dual  $\overline{\text{UCAS}}$  and  $\overline{\text{LCAS}}$  for independent byte control of read and write access.

Extended data out (EDO), also known as 'hyper-page mode,' enables high speed operation. In contrast to 'fast-page mode' devices, data remains active on outputs after  $\overline{\text{xCAS}}$  is de-asserted high, giving system logic more time to latch the data. Use  $\overline{\text{OE}}$  and  $\overline{\text{WE}}$  to control output impedance and prevent bus contention during read-modify-write and shared bus applications. Outputs also go to high impedance at the last occurrence of  $\overline{\text{RAS}}$  and  $\overline{\text{xCAS}}$  going high.

Refresh on the 1024 address combinations of A0 to A9 must be performed every 16 ms using:

- $\overline{\text{RAS}}$ -only refresh:  $\overline{\text{RAS}}$  is asserted while  $\overline{\text{xCAS}}$  is held high. Each of the 1024 rows must be strobed. Outputs remain high impedance.
- Hidden refresh:  $\overline{\text{xCAS}}$  is held low while  $\overline{\text{RAS}}$  is toggled. Outputs remain low impedance with previous valid data.
- $\overline{\text{CAS}}$ -before- $\overline{\text{RAS}}$  refresh (CBR): At least one  $\overline{\text{xCAS}}$  is asserted prior to  $\overline{\text{RAS}}$ . Refresh address is generated internally. Outputs are high-impedance ( $\overline{\text{OE}}$  and  $\overline{\text{WE}}$  are don't care).
- Normal read or write cycles refresh the row being accessed.

The AS4C1M16E5 is available in the standard 42-pin plastic SOJ and 44/50-pin TSOP II packages, respectively. The AS4C1M16E5 device operates with a single power supply of  $5\text{V} \pm 0.5\text{V}$  and provides TTL compatible inputs and outputs.

## Logic block diagram

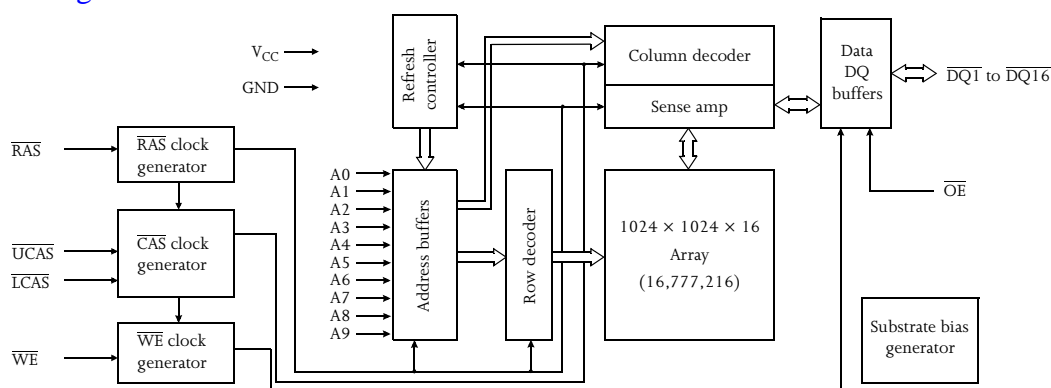

## Recommended operating conditions

Parameter	Symbol	Min	Nominal	Max	Unit
Supply voltage	$V_{CC}$	4.5	5.0	5.5	V
	GND	0.0	0.0	0.0	V
Input voltage	$V_{IH}$	2.4	—	$V_{CC}$	V
	$V_{IL}$	$-0.5^{\dagger}$	—	0.8	V
Ambient operating temperature	Commercial	0	—	70	$^{\circ}\text{C}$
	Industrial	-40	—	85	

$^{\dagger}V_{IL}$  min -3.0V for pulse widths less than 5 ns.

Recommended operating conditions apply throughout this document unless otherwise specified.



## Absolute maximum ratings

Parameter	Symbol	Min	Max	Unit
Input voltage	$V_{in}$	-1.0	+7.0	V
Input voltage (DQs)	$V_{DQ}$	-1.0	$V_{CC} + 0.5$	V
Power supply voltage	$V_{CC}$	-1.0	+7.0	V
Storage temperature (plastic)	$T_{STG}$	-65	+150	°C
Soldering temperature × time	$T_{SOLDER}$	–	$260 \times 10$	°C × sec
Power dissipation	$P_D$	–	1	W
Short circuit output current	$I_{out}$	–	50	mA

## Truth table

Operation	$\overline{RAS}$	$\overline{LCAS}$	$\overline{UCAS}$	$\overline{WE}$	$\overline{OE}$	Addresses		DQ0 to DQ15	Notes	
						$t_R$	$t_C$			
Standby	H	H to X	H to X	X	X	X	X	High-Z		
Word read	L	L	L	H	L	ROW	COL	Data out		
Lower byte read	L	L	H	H	L	ROW	COL	Lower byte, Upper byte, Data out		
Upper byte read	L	H	L	H	L	ROW	COL	Lower byte, Data out, Upper byte		
Word (early) write	L	L	L	L	X	ROW	COL	Data in		
Lower byte (early) write	L	L	H	L	X	ROW	COL	Lower byte, Data in, Upper byte, High-Z		
Upper byte (early) write	L	H	L	L	X	ROW	COL	Lower byte, High-Z, Upper byte, Data in		
Read write	L	L	L	H to L	L to H	ROW	COL	Data out, Data in	1,2	
EDO read	1st cycle	L	H to L	H to L	H	L	ROW	COL	Data out	2
	2nd cycle	L	H to L	H to L	H	L	n/a	COL	Data out	2
	Any cycle	L	L to H	L to H	H	L	n/a	n/a	Data out	2
EDO write	1st cycle	L	H to L	H to L	L	X	ROW	COL	Data in	1
	2nd cycle	L	H to L	H to L	L	X	n/a	COL	Data in	1
EDO read write	1st cycle	L	H to L	H to L	H to L	L to H	ROW	COL	Data out, Data in	1,2
	2nd cycle	L	H to L	H to L	H to L	L to H	n/a	COL	Data out, Data in	1,2
$\overline{RAS}$ only refresh	L	H	H	X	X	ROW	n/a	High Z		
CBR refresh	H to L	L	L	H	X	X	X	High Z	3	



## DC electrical characteristics

Parameter	Symbol	Test conditions	-45		-50		-60		Unit	Notes
			Min	Max	Min	Max	Min	Max		
Input leakage current	$I_{IL}$	$0V \leq V_{in} \leq V_{CC}$ (max) Pins not under test = 0V	-5	+5	-5	+5	-5	+5	$\mu A$	
Output leakage current	$I_{OL}$	$D_{OUT}$ disabled, $0V \leq V_{out} \leq V_{CC}$ (max)	-5	+5	-5	+5	-5	+5	$\mu A$	
Operating power supply current	$I_{CC1}$	$\overline{RAS}$ , $\overline{UCAS}$ , $\overline{LCAS}$ , Address cycling; $t_{RC} = \text{min}$	-	155	-	145	-	135	mA	4,5
TTL standby power supply current	$I_{CC2}$	$\overline{RAS} = \overline{UCAS} = \overline{LCAS} \geq V_{IH}$ , all other inputs at $V_{IH}$ or $V_{IL}$	-	2.0	-	2.0	-	2.0	mA	
Average power supply current, $\overline{RAS}$ refresh mode or CBR	$I_{CC3}$	$\overline{RAS}$ cycling, $\overline{UCAS} = \overline{LCAS} \geq V_{IH}$ , $t_{RC} = \text{min}$ of $\overline{RAS}$ low after $\overline{XCAS}$ low.	-	145	-	135	-	125	mA	4
EDO page mode average power supply current	$I_{CC4}$	$\overline{RAS} = V_{IL}$ , $\overline{UCAS}$ or $\overline{LCAS}$ , address cycling: $t_{HPC} = \text{min}$	-	130	-	120	-	110	mA	4, 5
CMOS standby power supply current	$I_{CC5}$	$\overline{RAS} = \overline{UCAS} = \overline{LCAS} = V_{CC} - 0.2V$ , $F = 0$	-	1.0	-	1.0	-	1.0	mA	
Output voltage	$V_{OH}$	$I_{OUT} = -5.0 \text{ mA}$	2.4	-	2.4	-	2.4	-	V	
	$V_{OL}$	$I_{OUT} = 4.2 \text{ mA}$	-	0.4	-	0.4	-	0.4	V	
$\overline{CAS}$ before $\overline{RAS}$ refresh current	$I_{CC6}$	$\overline{RAS}$ , $\overline{UCAS}$ or $\overline{LCAS}$ cycling, $t_{RC} = \text{min}$	-	155	-	145	-	135	mA	



## AC parameters common to all waveforms

Symbol	Parameter	-45		-50		-60		Unit	Notes
		Min	Max	Min	Max	Min	Max		
$t_{RC}$	Random read or write cycle time	75	–	80	–	100	–	ns	
$t_{RP}$	$\overline{RAS}$ precharge time	30	–	30	–	40	–	ns	
$t_{RAS}$	$\overline{RAS}$ pulse width	45	10K	50	10K	60	10K	ns	
$t_{CAS}$	$\overline{CAS}$ pulse width	8	10K	8	10K	10	10K	ns	
$t_{RCD}$	$\overline{RAS}$ to $\overline{CAS}$ delay time	15	35	15	35	15	43	ns	9
$t_{RAD}$	$\overline{RAS}$ to column address delay time	8	25	9	25	10	30	ns	10
$t_{RSH}$	$\overline{CAS}$ to $\overline{RAS}$ hold time	10	–	10	–	10	–	ns	
$t_{CSH}$	$\overline{RAS}$ to $\overline{CAS}$ hold time	40	–	40	–	50	–	ns	
$t_{CRP}$	$\overline{CAS}$ to $\overline{RAS}$ precharge time	5	–	5	–	5	–	ns	
$t_{ASR}$	Row address setup time	0	–	0	–	0	–	ns	
$t_{RAH}$	Row address hold time	8	–	8	–	10	–	ns	
$t_T$	Transition time (rise and fall)	1	50	1	50	1	50	ns	7,8
$t_{REF}$	Refresh period	–	16	–	16	–	16	ms	6
$t_{CP}$	CAS precharge time	8	–	8	–	10	–	ns	
$t_{RAL}$	Column address to $\overline{RAS}$ lead time	25	–	25	–	30	–	ns	
$t_{ASC}$	Column address setup time	0	–	0	–	0	–	ns	
$t_{CAH}$	Column address hold time	8	–	8	–	10	–	ns	

## Read cycle

Symbol	Parameter	-45		-50		-60		Unit	Notes
		Min	Max	Min	Max	Min	Max		
$t_{RAC}$	Access time from $\overline{RAS}$	–	45	–	50	–	60	ns	9
$t_{CAC}$	Access time from $\overline{CAS}$	–	10	–	12	–	15	ns	9,16
$t_{AA}$	Access time from address	–	23	–	25	–	30	ns	10,16
$t_{RCS}$	Read command setup time	0	–	0	–	0	–	ns	
$t_{RCH}$	Read command hold time to $\overline{CAS}$	0	–	0	–	0	–	ns	12
$t_{RRH}$	Read command hold time to $\overline{RAS}$	0	–	0	–	0	–	ns	12



## Write cycle

Symbol	Parameter	-45		-50		-60		Unit	Notes
		Min	Max	Min	Max	Min	Max		
$t_{WCS}$	Write command setup time	0	–	0	–	0	–	ns	14
$t_{WCH}$	Write command hold time	10	–	10	–	10	–	ns	14
$t_{WP}$	Write command pulse width	10	–	10	–	10	–	ns	
$t_{RWL}$	Write command to $\overline{RAS}$ lead time	10	–	10	–	10	–	ns	
$t_{CWL}$	Write command to $\overline{CAS}$ lead time	8	–	8	–	10	–	ns	
$t_{DS}$	Data-in setup time	0	–	0	–	0	–	ns	15
$t_{DH}$	Data-in hold time	8	–	8	–	10	–	ns	15

## Read-modify-write cycle

Symbol	Parameter	-45		-50		-60		Unit	Notes
		Min	Max	Min	Max	Min	Max		
$t_{RWC}$	Read-write cycle time	105	–	113	–	135	–	ns	
$t_{RWD}$	$\overline{RAS}$ to $\overline{WE}$ delay time	65	–	67	–	77	–	ns	14
$t_{CWD}$	$\overline{CAS}$ to $\overline{WE}$ delay time	30	–	32	–	35	–	ns	14
$t_{AWD}$	Column address to $\overline{WE}$ delay time	40	–	42	–	47	–	ns	14

## Refresh cycle

Symbol	Parameter	-45		-50		-60		Unit	Notes
		Min	Max	Min	Max	Min	Max		
$t_{CSR}$	$\overline{CAS}$ setup time ( $\overline{CAS}$ -before- $\overline{RAS}$ )	5	–	5	–	5	–	ns	6
$t_{CHR}$	$\overline{CAS}$ hold time ( $\overline{CAS}$ -before- $\overline{RAS}$ )	8	–	8	–	10	–	ns	6
$t_{RPC}$	$\overline{RAS}$ precharge to $\overline{CAS}$ hold time	0	–	0	–	0	–	ns	
$t_{CPT}$	$\overline{CAS}$ precharge time (CBR counter test)	10	–	10	–	10	–	ns	



## Hyper page mode cycle

Symbol	Parameter	-45		-50		-60		Unit	Notes
		Min	Max	Min	Max	Min	Max		
$t_{CPWD}$	$\overline{CAS}$ precharge to $\overline{WE}$ delay time	45	–	45	–	52	–	ns	
$t_{CPA}$	Access time from $\overline{CAS}$ precharge	–	28	–	28	–	35	ns	16
$t_{RASP}$	$\overline{RAS}$ pulse width	45	100K	50	100K	60	100K	ns	
$t_{DOH}$	Previous data hold time from $\overline{CAS}$	5	–	5	–	5	–	ns	
$t_{REZ}$	Output buffer turn off delay from $\overline{RAS}$	0	13	0	13	0	15	ns	
$t_{WEZ}$	Output buffer turn off delay from $\overline{WE}$	0	13	0	13	0	15	ns	
$t_{OEZ}$	Output buffer turn off delay from $\overline{OE}$	0	13	0	13	0	15	ns	
$t_{HPC}$	Hyper page mode cycle time	20	–	20	–	25	–	ns	
$t_{HPRWC}$	Hyper page mode RMW cycle	47	–	47	–	56	–	ns	
$t_{RHCP}$	$\overline{RAS}$ hold time from $\overline{CAS}$	30	–	30	–	35	–	ns	

## Output enable

Symbol	Parameter	-45		-50		-60		Unit	Notes
		Min	Max	Min	Max	Min	Max		
$t_{CLZ}$	$\overline{CAS}$ to output in Low Z	0	–	0	–	0	–	ns	11
$t_{ROH}$	$\overline{RAS}$ hold time referenced to $\overline{OE}$	8	–	8	–	10	–	ns	
$t_{OEA}$	$\overline{OE}$ access time	–	13	–	13	–	15	ns	
$t_{OED}$	$\overline{OE}$ to data delay	13	–	13	–	15	–	ns	
$t_{OEZ}$	Output buffer turnoff delay from $\overline{OE}$	0	13	0	13	0	15	ns	11
$t_{OEH}$	$\overline{OE}$ command hold time	10	–	10	–	10	–	ns	
$t_{OLZ}$	$\overline{OE}$ to output in Low Z	0	–	0	–	0	–	ns	
$t_{OFF}$	Output buffer turn-off time	0	13	0	13	0	15	ns	11,13



## Notes

- Write cycles may be byte write cycles (either  $\overline{\text{LCAS}}$  or  $\overline{\text{UCAS}}$  active).
- Read cycles may be byte read cycles (either  $\overline{\text{LCAS}}$  or  $\overline{\text{UCAS}}$  active).
- One  $\overline{\text{CAS}}$  must be active (either  $\overline{\text{LCAS}}$  or  $\overline{\text{UCAS}}$ ).
- $I_{\text{CC1}}$ ,  $I_{\text{CC3}}$ ,  $I_{\text{CC4}}$ , and  $I_{\text{CC6}}$  are dependent on frequency.
- $I_{\text{CC1}}$  and  $I_{\text{CC4}}$  depend on output loading. Specified values are obtained with the output open.
- An initial pause of 200  $\mu\text{s}$  is required after power-up followed by any 8  $\overline{\text{RAS}}$  cycles before proper device operation is achieved. In the case of an internal refresh counter, a minimum of 8  $\overline{\text{CAS}}$ -before- $\overline{\text{RAS}}$  initialization cycles instead of 8  $\overline{\text{RAS}}$  cycles are required. 8 initialization cycles are required after extended periods of bias without clocks (greater than 8 ms).
- AC Characteristics assume  $t_T = 2$  ns. All AC parameters are measured with a load as described in AC test conditions below.
- $V_{\text{IH}}$  (min) and  $V_{\text{IL}}$  (max) are reference levels for measuring timing of input signals. Transition times are measured between  $V_{\text{IH}}$  and  $V_{\text{IL}}$ .
- Operation within the  $t_{\text{RCD}}$  (max) limit insures that  $t_{\text{RAC}}$  (max) can be met.  $t_{\text{RCD}}$  (max) is specified as a reference point only. If  $t_{\text{RCD}}$  is greater than the specified  $t_{\text{RCD}}$  (max) limit, then access time is controlled exclusively by  $t_{\text{CAC}}$ .
- Operation within the  $t_{\text{RAD}}$  (max) limit insures that  $t_{\text{RAC}}$  (max) can be met.  $t_{\text{RAD}}$  (max) is specified as a reference point only. If  $t_{\text{RAD}}$  is greater than the specified  $t_{\text{RAD}}$  (max) limit, then access time is controlled exclusively by  $t_{\text{AA}}$ .
- Assumes three state test load (5 pF and a 380  $\Omega$  Thevenin equivalent).
- Either  $t_{\text{RCH}}$  or  $t_{\text{RRH}}$  must be satisfied for a read cycle.
- $t_{\text{OFF}}$  (max) defines the time at which the output achieves the open circuit condition; it is not referenced to output voltage levels.  $t_{\text{OFF}}$  is referenced from rising edge of  $\overline{\text{RAS}}$  or  $\overline{\text{CAS}}$ , whichever occurs last.
- $t_{\text{WCS}}$ ,  $t_{\text{WCH}}$ ,  $t_{\text{RWD}}$ ,  $t_{\text{CWD}}$  and  $t_{\text{AWD}}$  are not restrictive operating parameters. They are included in the datasheet as electrical characteristics only. If  $t_{\text{WS}} \geq t_{\text{WS}}$  (min) and  $t_{\text{WH}} \geq t_{\text{WH}}$  (min), the cycle is an early write cycle and data out pins will remain open circuit, high impedance, throughout the cycle. If  $t_{\text{RWD}} \geq t_{\text{RWD}}$  (min),  $t_{\text{CWD}} \geq t_{\text{CWD}}$  (min) and  $t_{\text{AWD}} \geq t_{\text{AWD}}$  (min), the cycle is a read-write cycle and the data out will contain data read from the selected cell. If neither of the above conditions is satisfied, the condition of the data out at access time is indeterminate.
- These parameters are referenced to  $\overline{\text{CAS}}$  leading edge in early write cycles and to  $\overline{\text{WE}}$  leading edge in read-write cycles.
- Access time is determined by the longest of  $t_{\text{CAA}}$  or  $t_{\text{CAC}}$  or  $t_{\text{CPA}}$
- $t_{\text{ASC}} \geq t_{\text{CP}}$  to achieve  $t_{\text{PC}}$  (min) and  $t_{\text{CPA}}$  (max) values.
- These parameters are sampled and not 100% tested.
- These characteristics apply to AS4C1M16E5 5V devices.

## AC test conditions

- Access times are measured with output reference levels of  $V_{\text{OH}} = 2.4\text{V}$  and  $V_{\text{OL}} = 0.4\text{V}$ ,  $V_{\text{IH}} = 2.4\text{V}$  and  $V_{\text{IL}} = 0.8\text{V}$
- Input rise and fall times: 2 ns

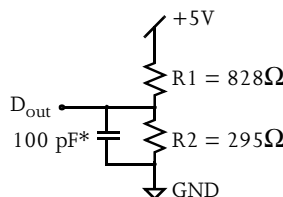

Figure A: Equivalent output load (AS4C1M16E5)

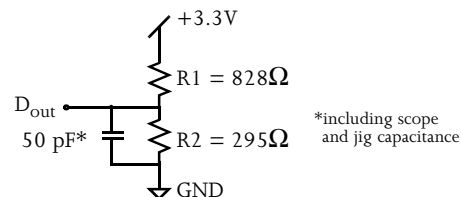

Figure B: Equivalent output load (AS4LC1M16E5)

## Key to switching waveforms



Rising input



Falling input



Undefined output/don't care



Read waveform

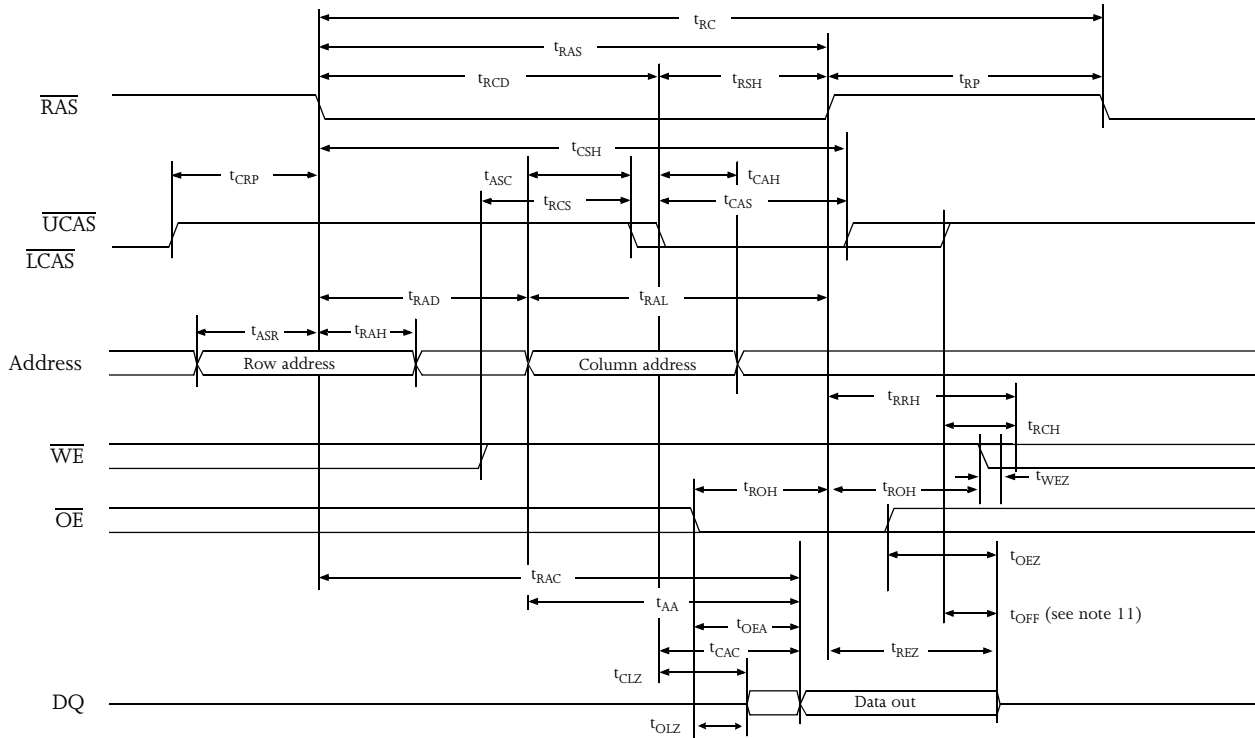

Upper byte read waveform

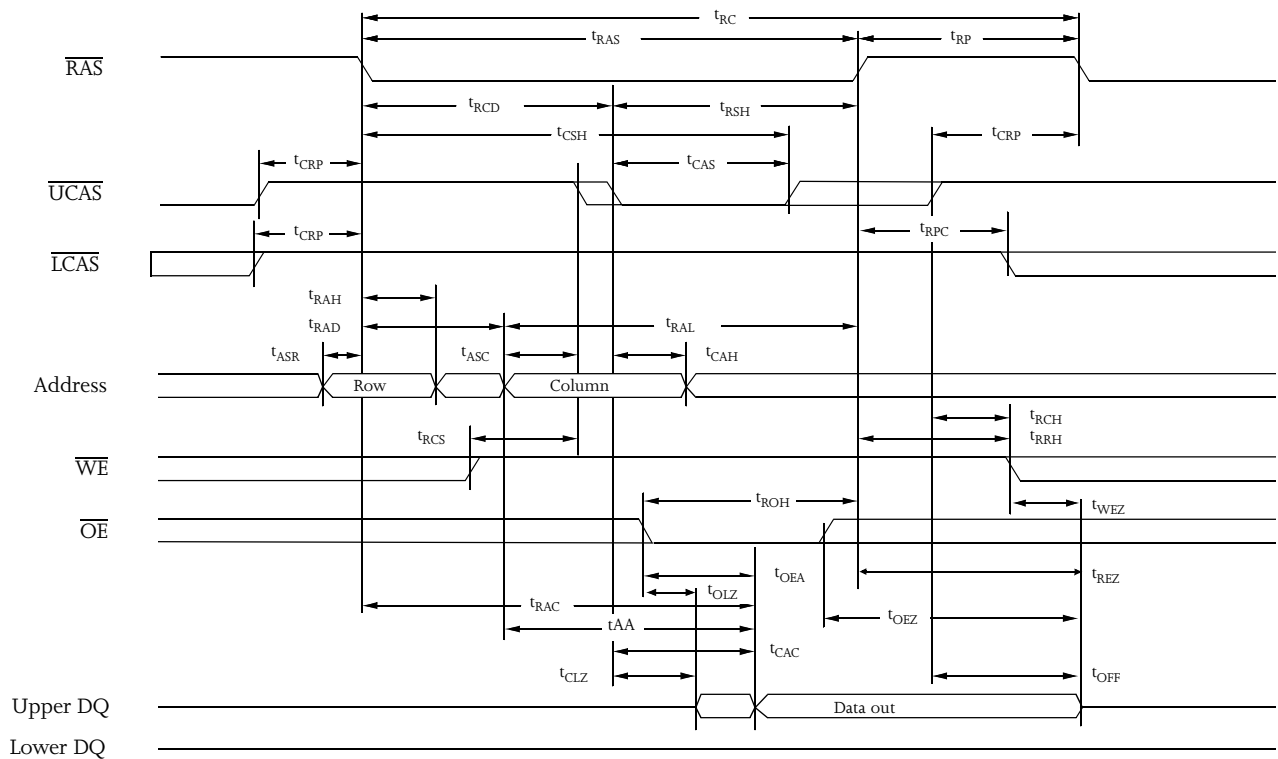



Lower byte read waveform

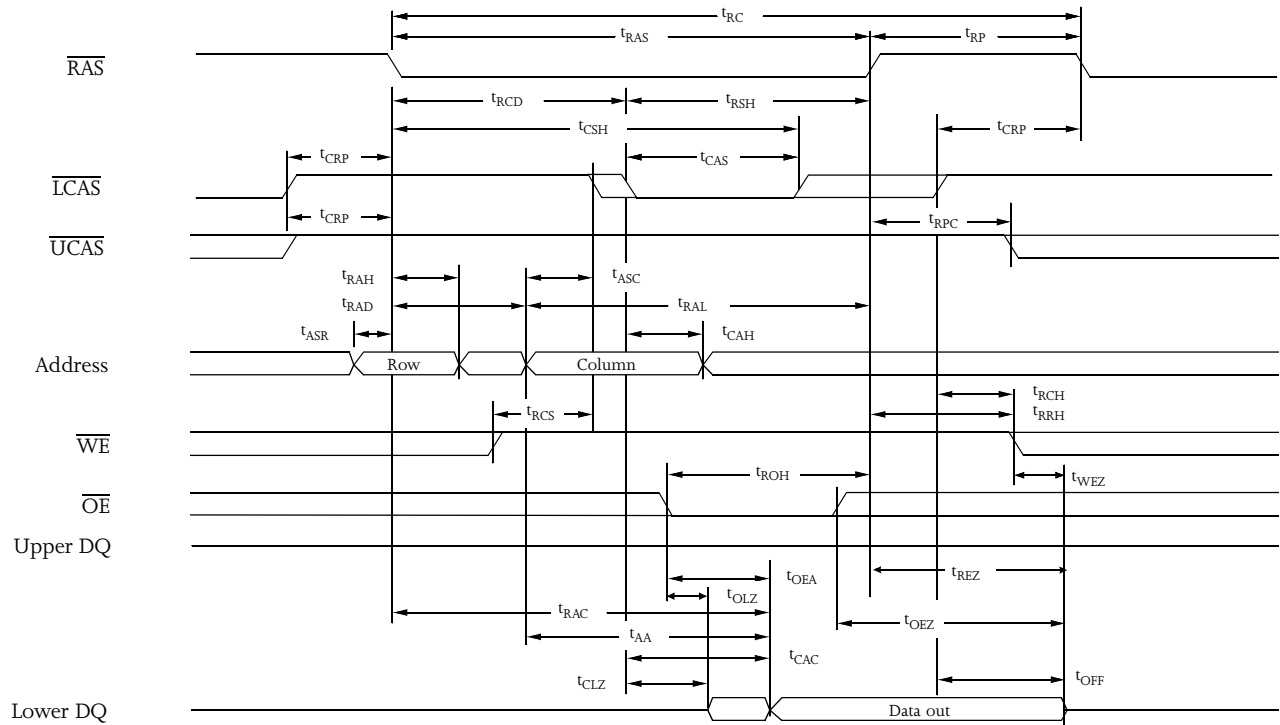

Early write waveform

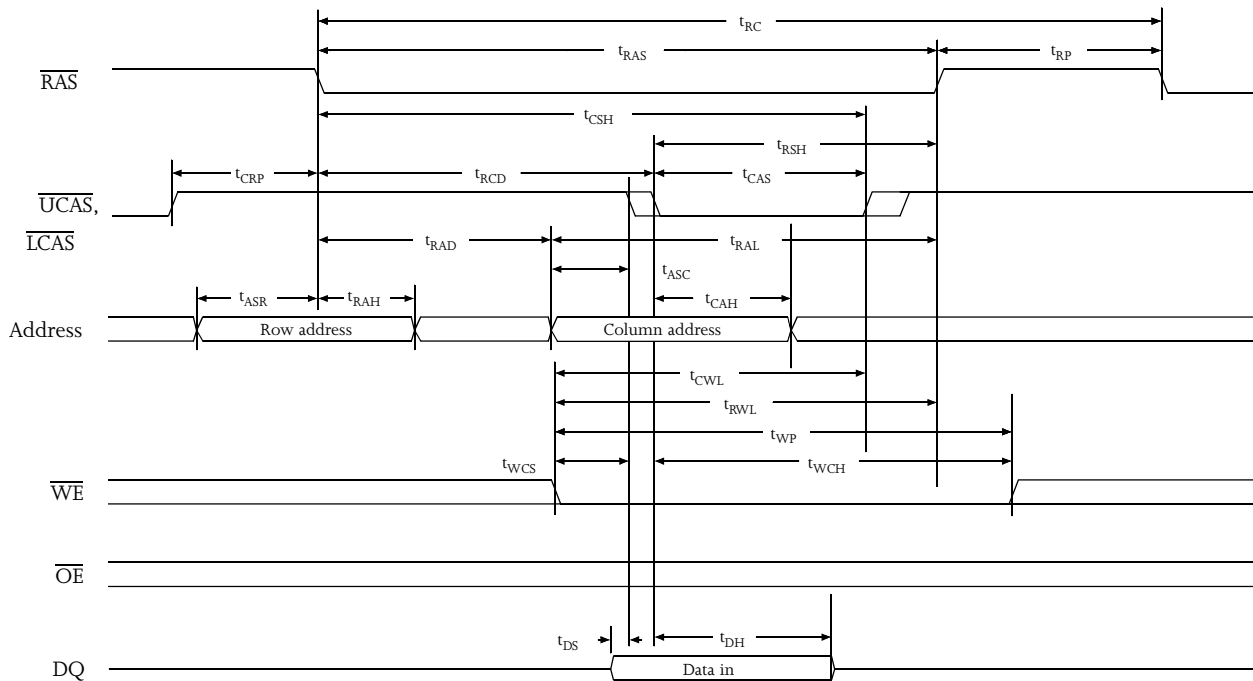



Upper byte early write waveform

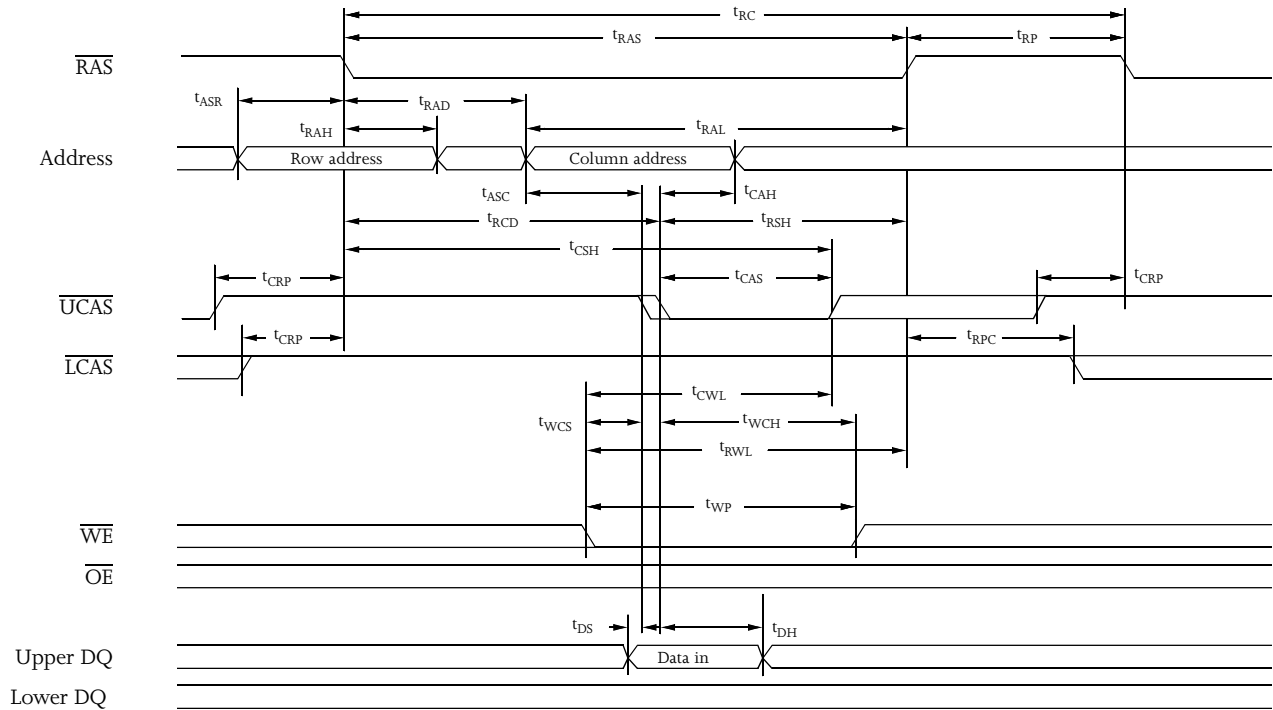

Lower byte early write waveform

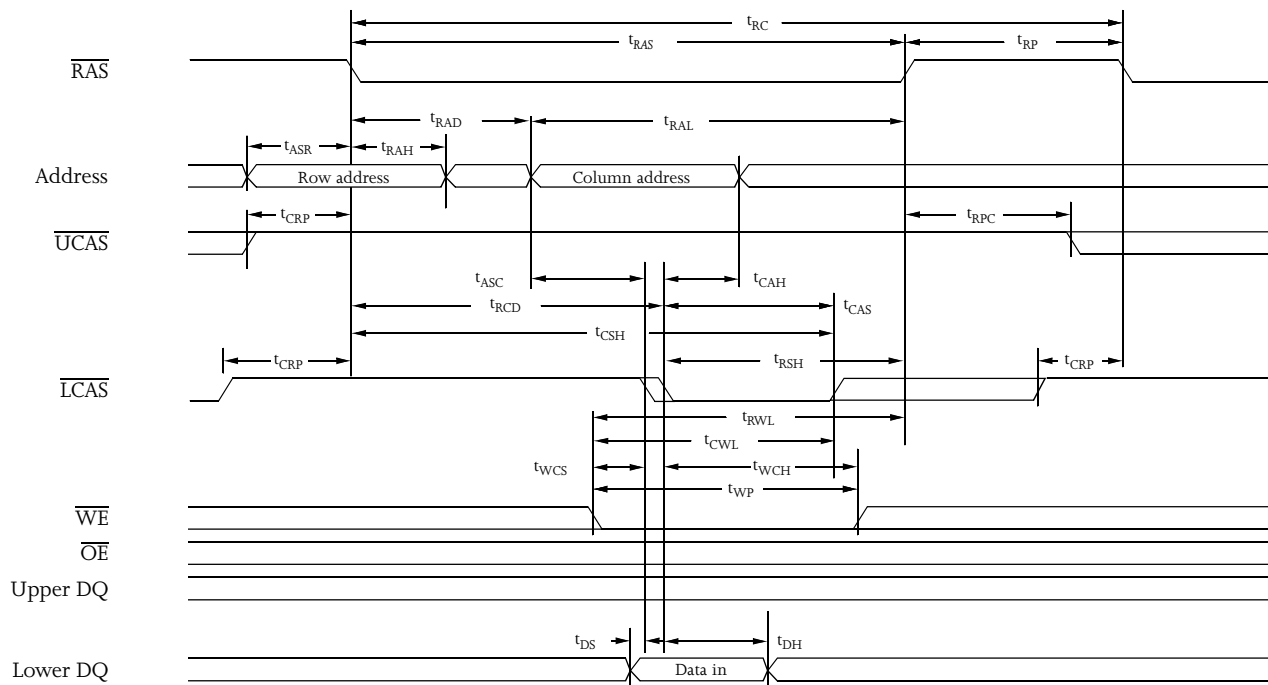



Write waveform

$\overline{OE}$  controlled

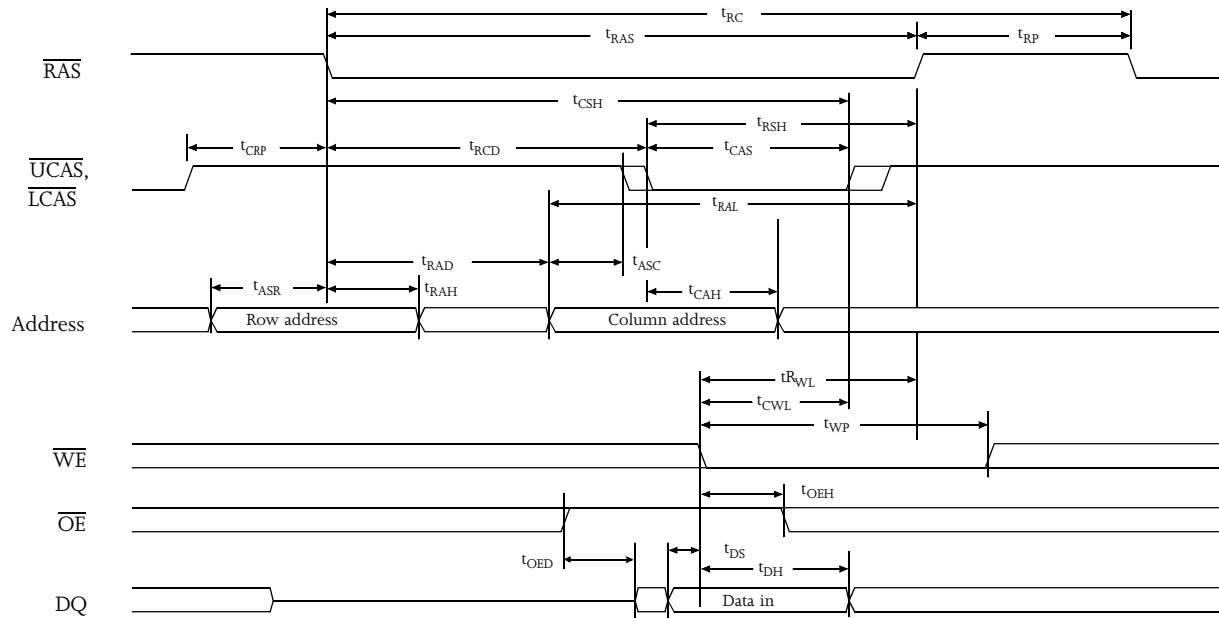

Upper byte write waveform

$\overline{OE}$  controlled

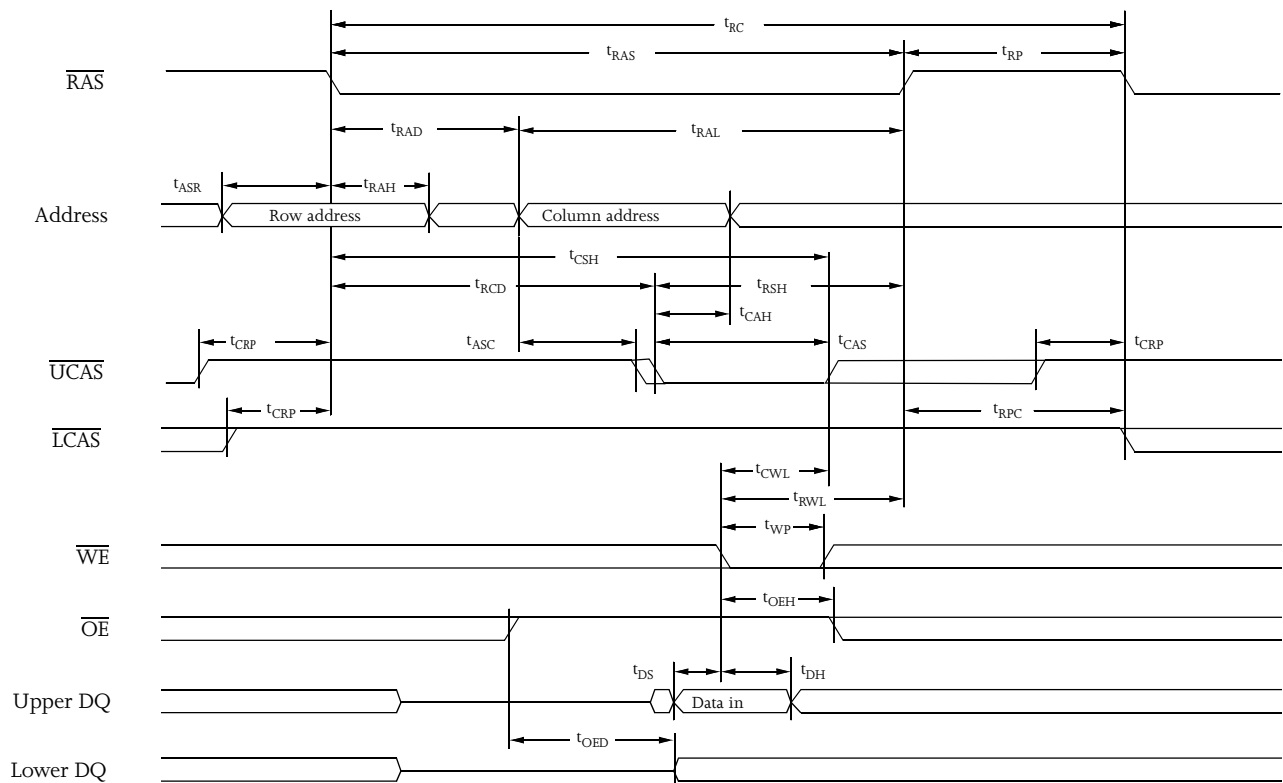



Lower byte write waveform

$\overline{OE}$  controlled

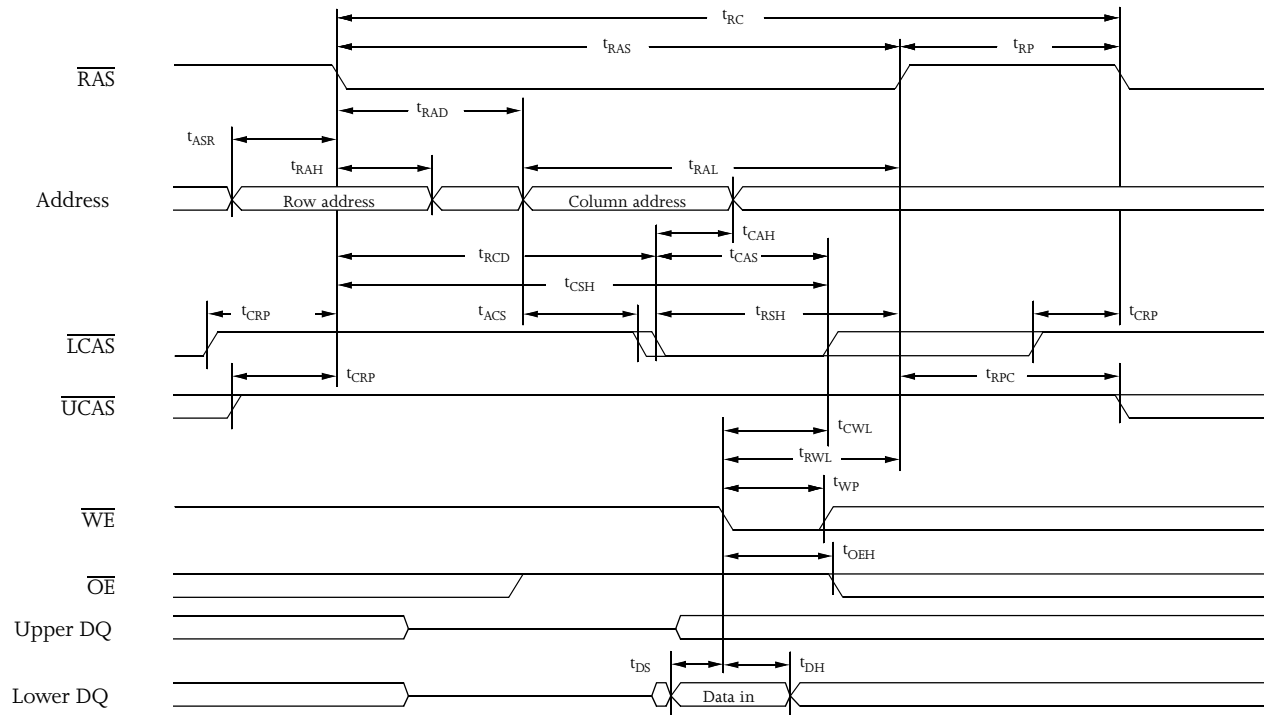

Read-modify-write waveform

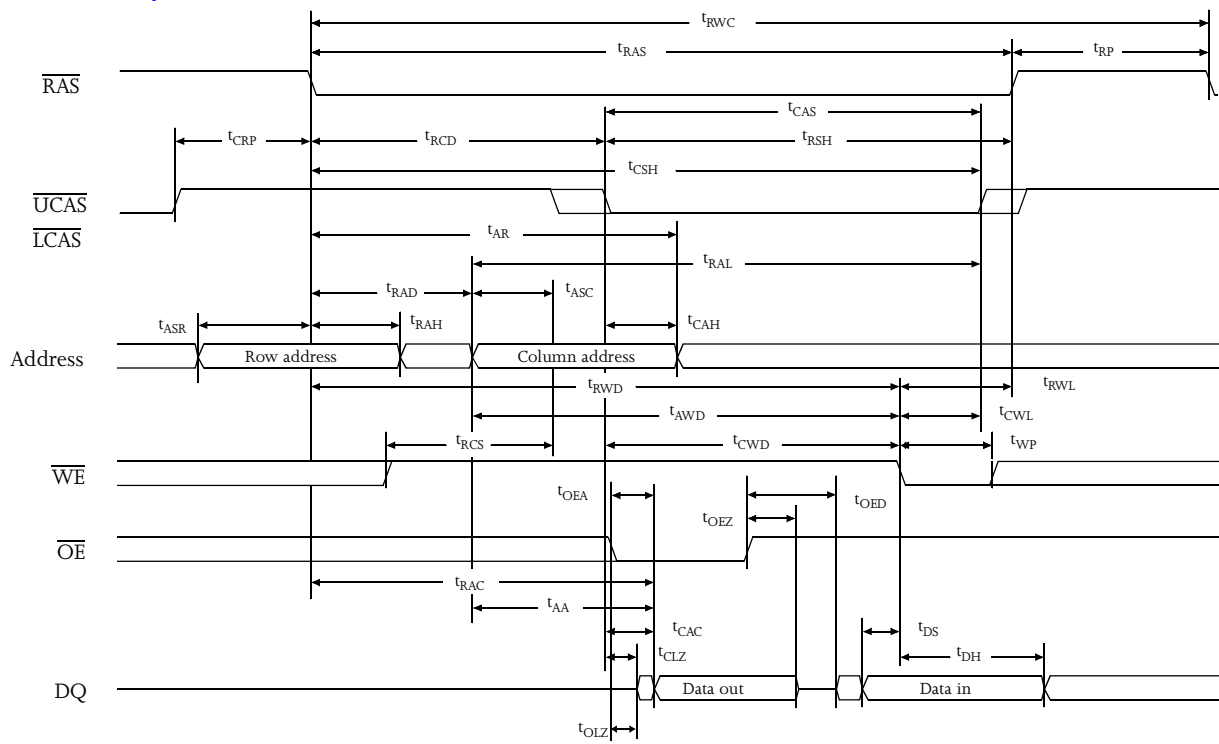



Upper byte read-modify-write waveform

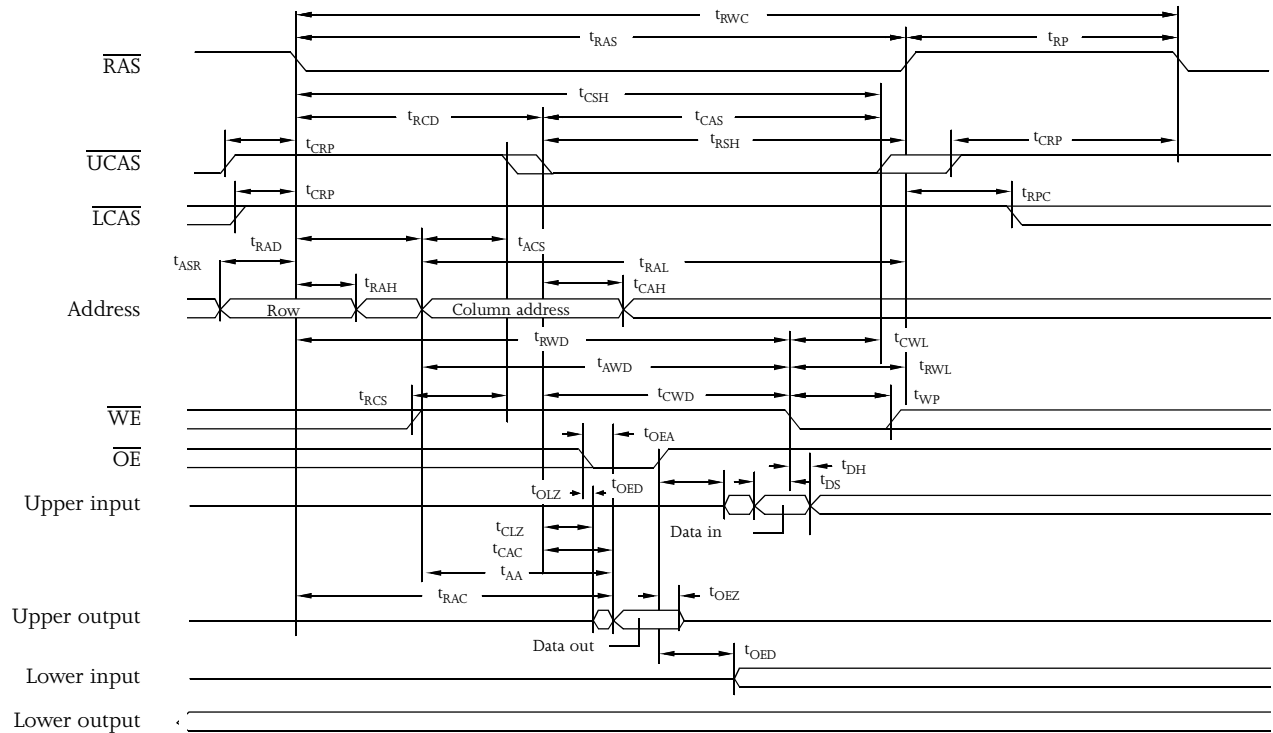

Lower byte read-modify-write waveform

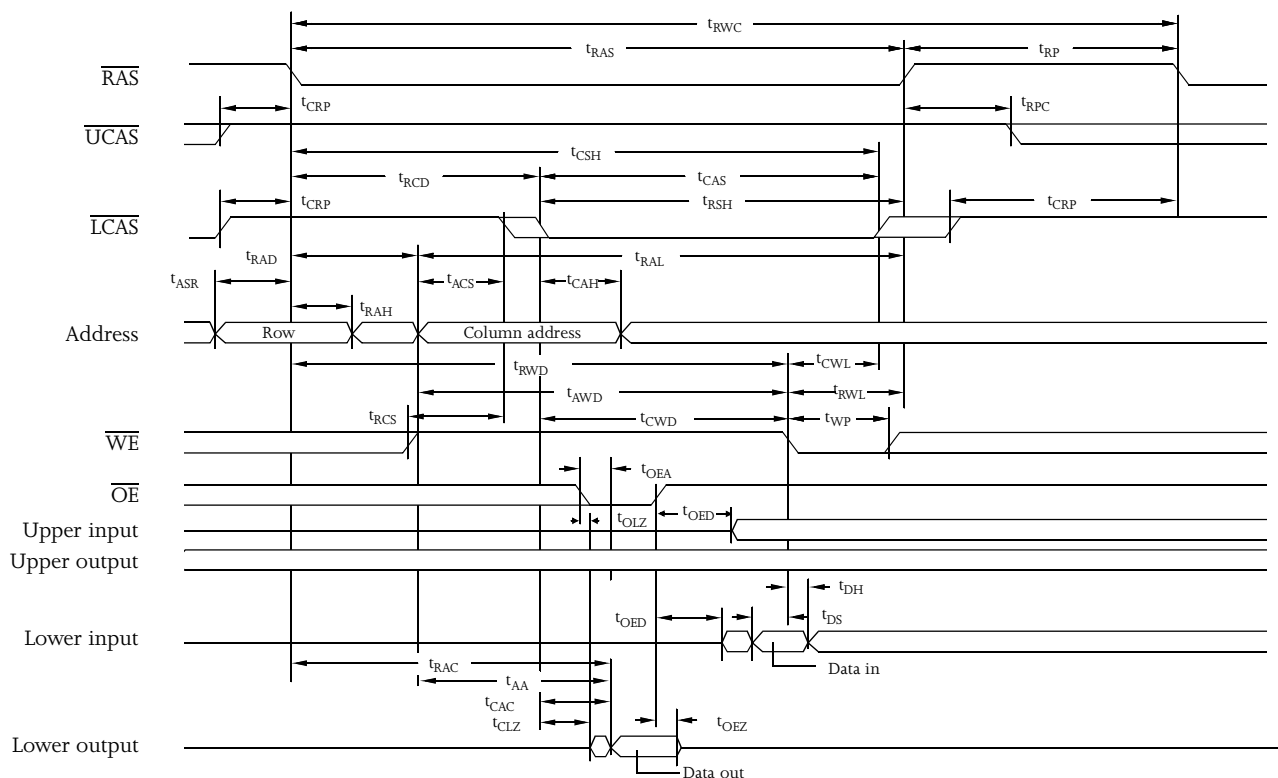



Hyper page mode read waveform

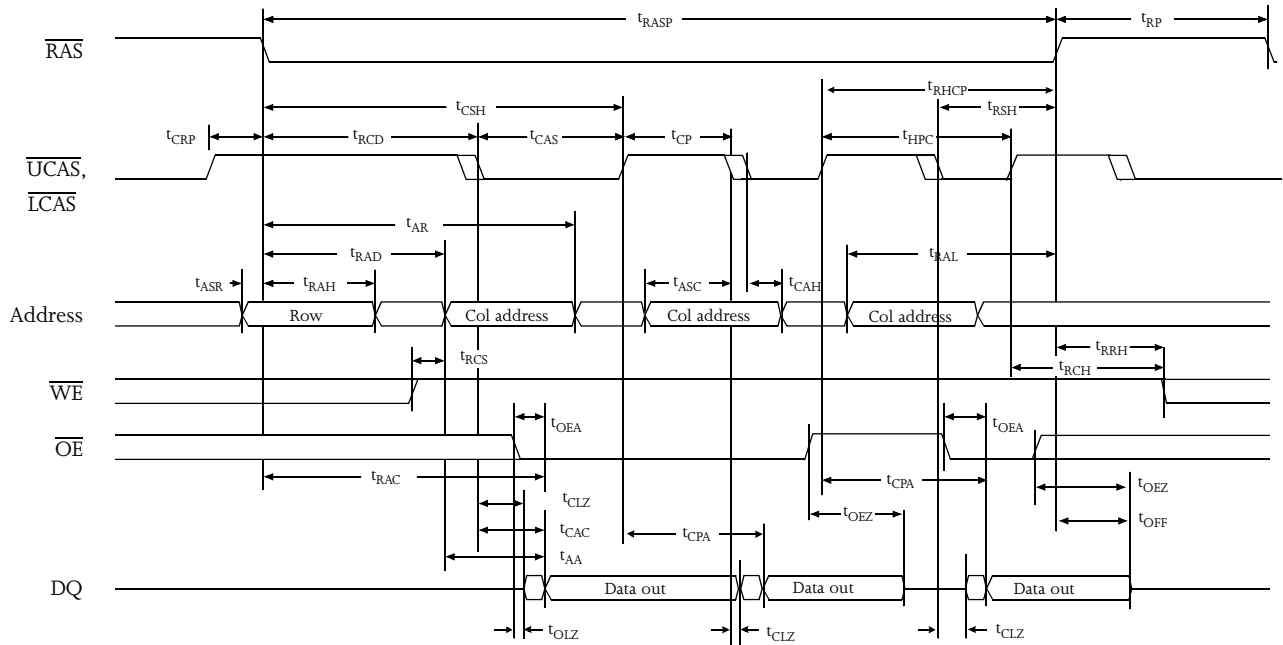

Hyper page mode byte write waveform

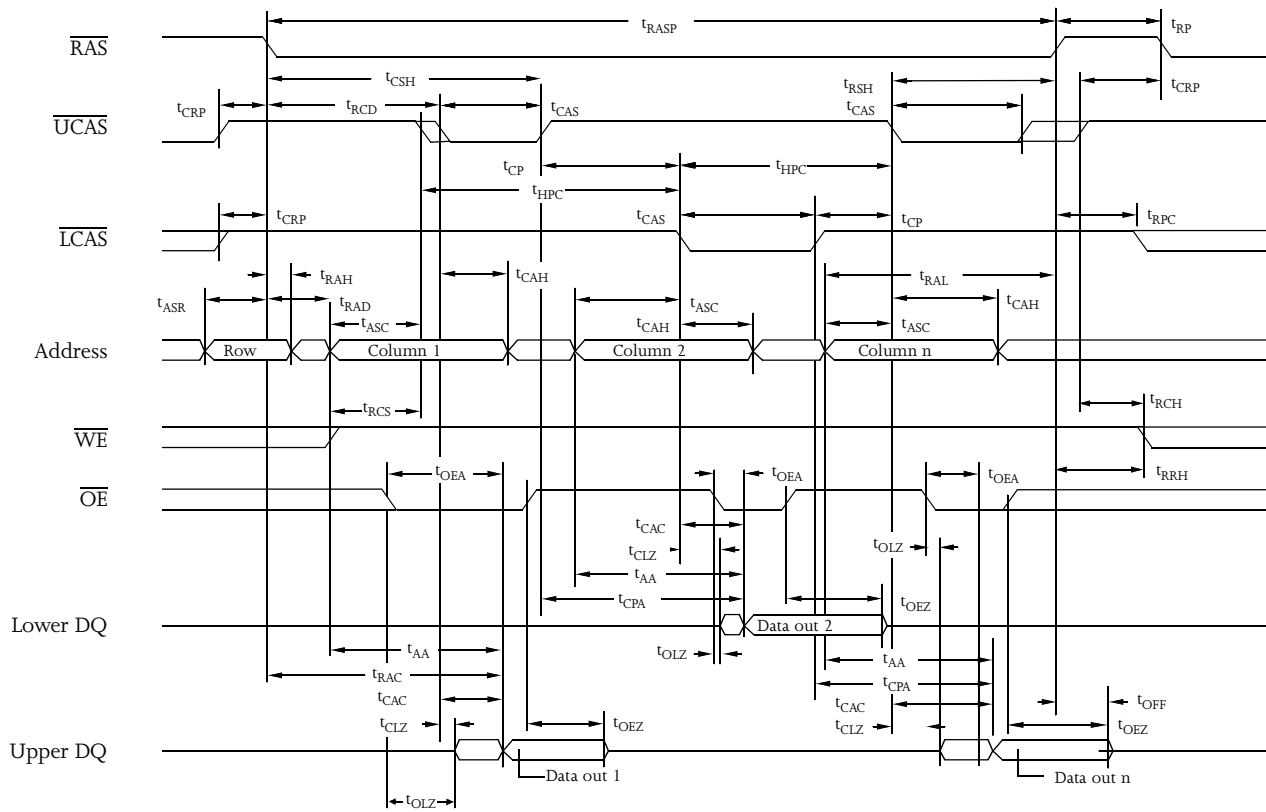





Hyper page mode read-modify-write waveform

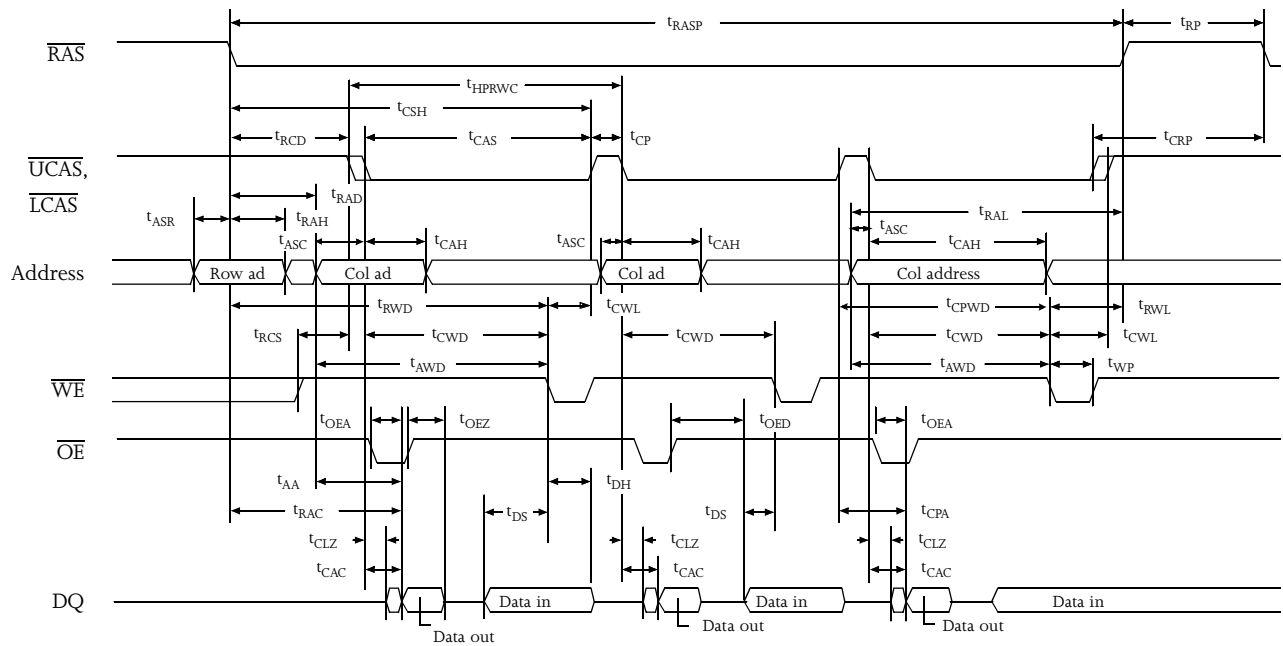

CAS before RAS refresh waveform

$\overline{WE} = V_{IH}$

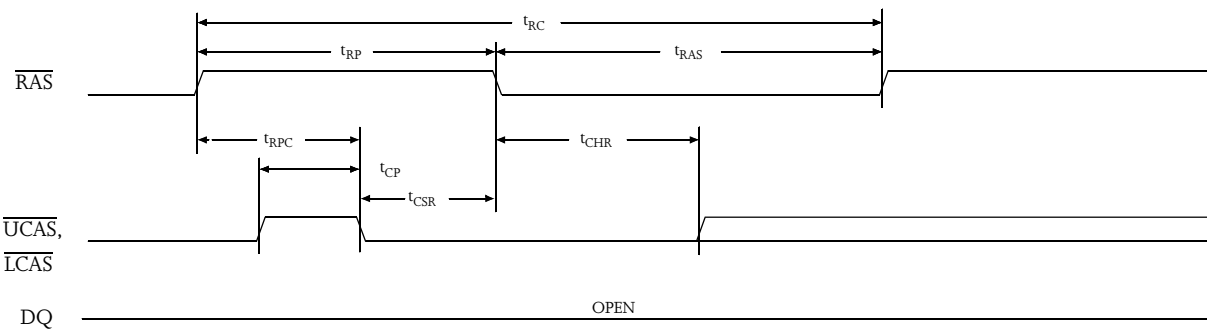

RAS only refresh waveform

$\overline{WE} = \overline{OE} = V_{IH}$  or  $V_{IL}$

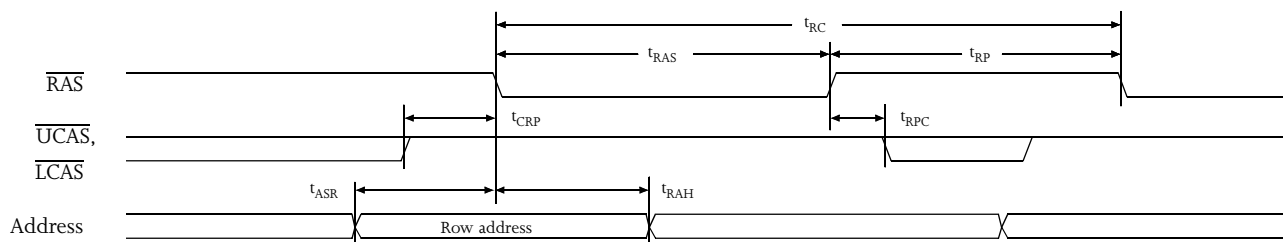





Hidden refresh waveform (read)

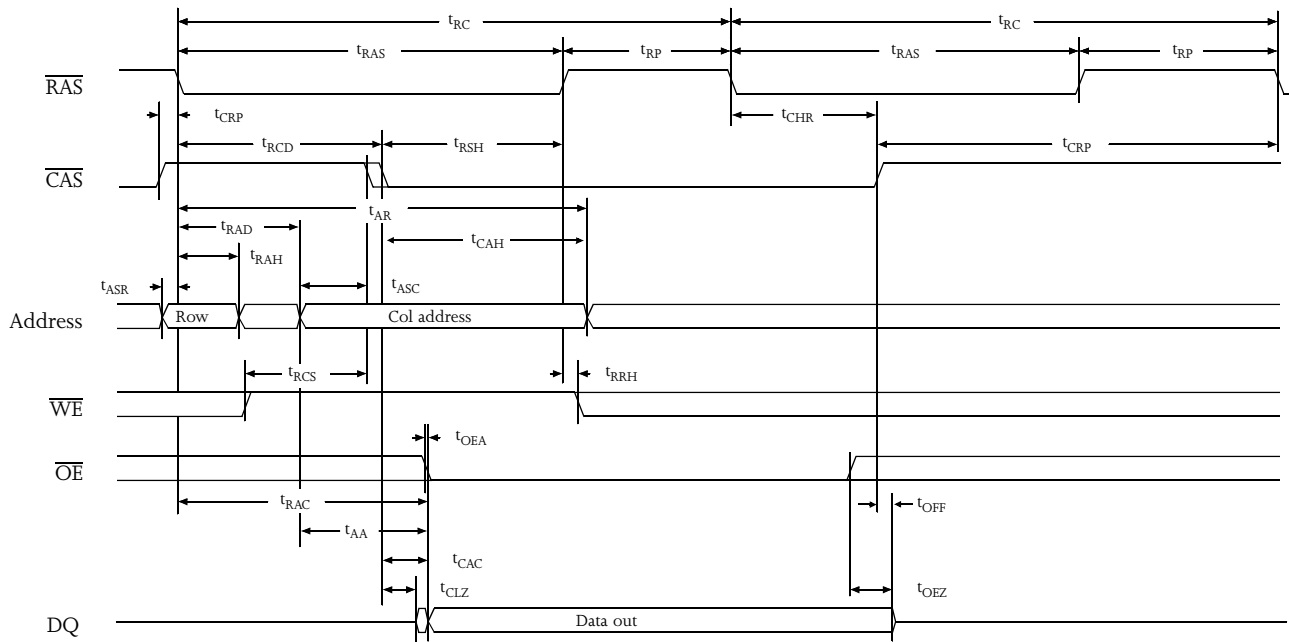

Hidden refresh waveform (write)

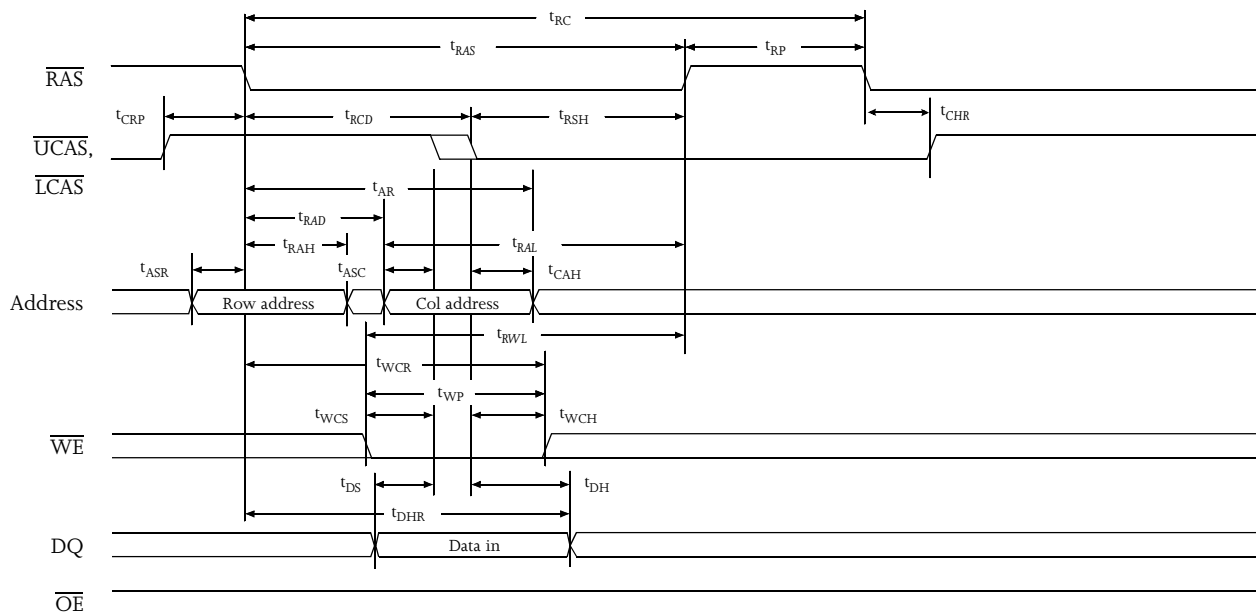



CAS before RAS refresh counter test waveform

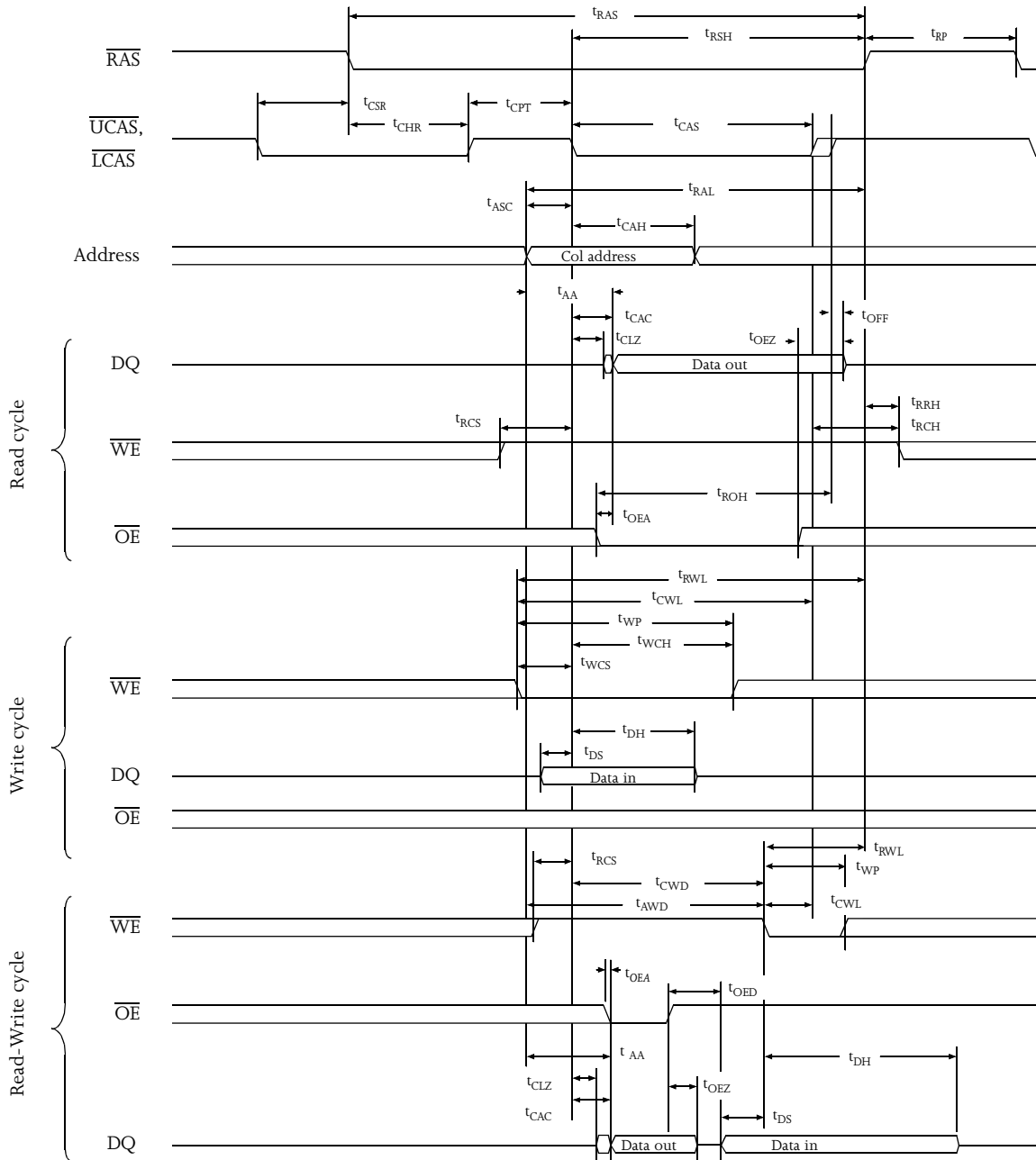



Package dimensions

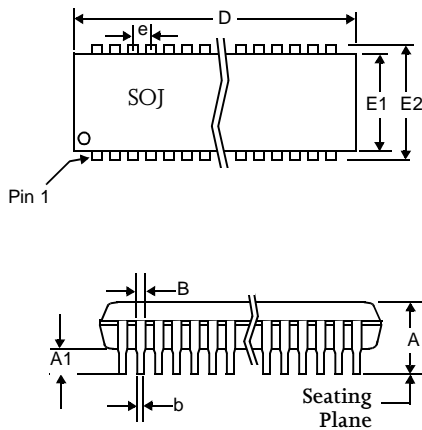

42-pin SOJ

	Min	Max
A	0.128	0.148
A1	0.025	-
A2	0.105	0.115
B	0.026	0.032
b	0.015	0.020
c	0.007	0.013
D	1.070	1.080
E	0.370 NOM	
E1	0.395	0.405
E2	0.435	0.445
e	0.050 NOM	

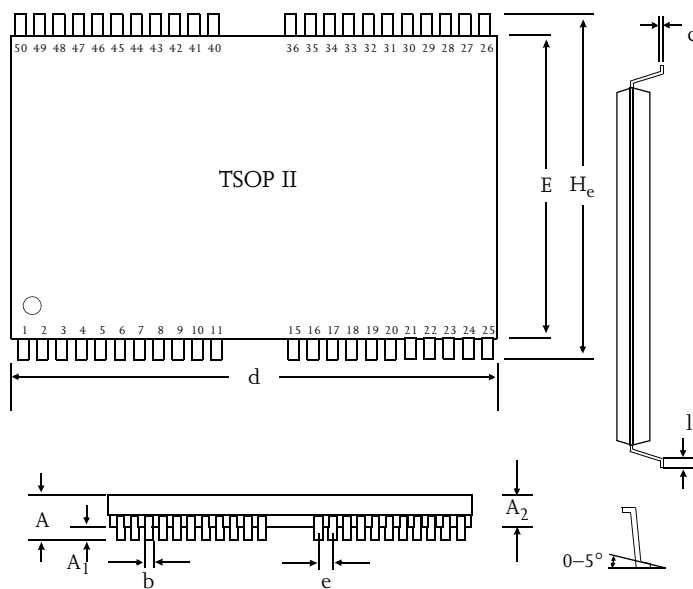

50-pin TSOP II

	Min (mm)	Max (mm)
A		1.2
A <sub>1</sub>	0.05	
A <sub>2</sub>	0.95	1.05
b	0.30	0.45
c	0.12	0.21
d	20.85	21.05
E	10.03	10.29
He	11.56	11.96
e	0.80 (typical)	
l	0.40	0.60

Capacitance <sup>15</sup>

$f = 1 \text{ MHz}, T_a = \text{Room temperature}$

Parameter	Symbol	Signals	Test conditions	Max	Unit
Input capacitance	$C_{IN1}$	A0 to A9	$V_{in} = 0V$	5	pF
	$C_{IN2}$	RAS, $\overline{UCAS}$ , $\overline{LCAS}$ , $\overline{WE}$ , $\overline{OE}$	$V_{in} = 0V$	7	pF
DQ capacitance	$C_{DQ}$	DQ0 to DQ15	$V_{in} = V_{out} = 0V$	7	pF



## AS4C1M16E5 ordering information

Package \ $\overline{\text{RAS}}$ access time	45 ns	50 ns	60 ns
Plastic SOJ, 400 mil, 42-pin	AS4C1M16E5-45JC	AS4C1M16E5-50JC	AS4C1M16E5-60JC
		AS4C1M16E5-50JI	AS4C1M16E5-60JI
TSOP II, 400 mil, 44/50-pin	AS4C1M16E5-45TC	AS4C1M16E5-50TC	AS4C1M16E5-60TC
		AS4C1M16E5-50TI	AS4C1M16E5-60TI

## AS4C1M16E5 part numbering system

AS4	C	1M16E5	-XX	X	X
DRAM prefix	C = 5V CMOS LC = 3.3V CMOS	Device number	$\overline{\text{RAS}}$ access time	Package: J = 42-pin SOJ 400 mil T = 44/50-pin TSOP II 400 mil	Temperature range C=Commercial, 0°C to 70 °C I=Industrial, -40°C to 85°C



LittleDiode supplies new, hard to find or obsolete electronic components and semiconductors all over the world.

With over two million different components listed you are sure to find the part you need.

Feel free to visit us today at our online store:

**[LittleDiode.com](http://LittleDiode.com)**

Looking forward to providing you with the best possible service.