

SN74LVC245A OCTAL BUS TRANSCEIVER WITH 3-STATE OUTPUTS

SCAS218I – JANUARY 1993 – REVISED JUNE 1998

- **EPIC™ (Enhanced-Performance Implanted CMOS) Submicron Process**
- **Typical V_{OLP} (Output Ground Bounce) < 0.8 V at $V_{CC} = 3.3$ V, $T_A = 25^\circ\text{C}$**
- **Typical V_{OHV} (Output V_{OH} Undershoot) > 2 V at $V_{CC} = 3.3$ V, $T_A = 25^\circ\text{C}$**
- **Supports Mixed-Mode Signal Operation on All Ports (5-V Input/Output Voltage With 3.3-V V_{CC})**
- **Power Off Disables Outputs, Permitting Live Insertion**
- **ESD Protection Exceeds 2000 V Per MIL-STD-883, Method 3015; Exceeds 200 V Using Machine Model (C = 200 pF, R = 0)**
- **Latch-Up Performance Exceeds 250 mA Per JESD 17**
- **Package Options Include Plastic Small-Outline (DW), Shrink Small-Outline (DB), and Thin Shrink Small-Outline (PW) Packages**

DB, DW, OR PW PACKAGE
(TOP VIEW)

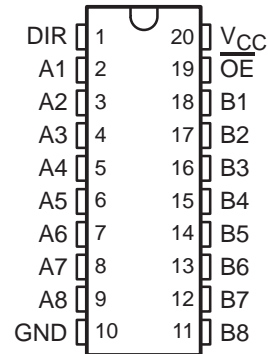

description

This octal bus transceiver is designed for 1.65-V to 3.6-V V_{CC} operation.

The SN74LVC245A is designed for asynchronous communication between data buses. The device transmits data from the A bus to the B bus or from the B bus to the A bus, depending on the logic level at the direction-control (DIR) input. The output-enable (\overline{OE}) input can be used to disable the device so the buses are effectively isolated.

To ensure the high-impedance state during power up or power down, \overline{OE} should be tied to V_{CC} through a pullup resistor; the minimum value of the resistor is determined by the current-sinking capability of the driver.

Inputs can be driven from either 3.3-V or 5-V devices. This feature allows the use of these devices as translators in a mixed 3.3-V/5-V system environment.

The SN74LVC245A is characterized for operation from -40°C to 85°C .

FUNCTION TABLE

| INPUTS | | OPERATION |
|-----------------|-----|-----------------|
| \overline{OE} | DIR | |
| L | L | B data to A bus |
| L | H | A data to B bus |
| H | X | Isolation |



Please be aware that an important notice concerning availability, standard warranty, and use in critical applications of Texas Instruments semiconductor products and disclaimers thereto appears at the end of this data sheet.

EPIC is a trademark of Texas Instruments Incorporated.

PRODUCTION DATA information is current as of publication date. Products conform to specifications per the terms of Texas Instruments standard warranty. Production processing does not necessarily include testing of all parameters.

**TEXAS
INSTRUMENTS**

POST OFFICE BOX 655303 • DALLAS, TEXAS 75265

Copyright © 1998, Texas Instruments Incorporated

SN74LVC245A OCTAL BUS TRANSCEIVER WITH 3-STATE OUTPUTS

SCAS2181 – JANUARY 1993 – REVISED JUNE 1998

logic symbol†

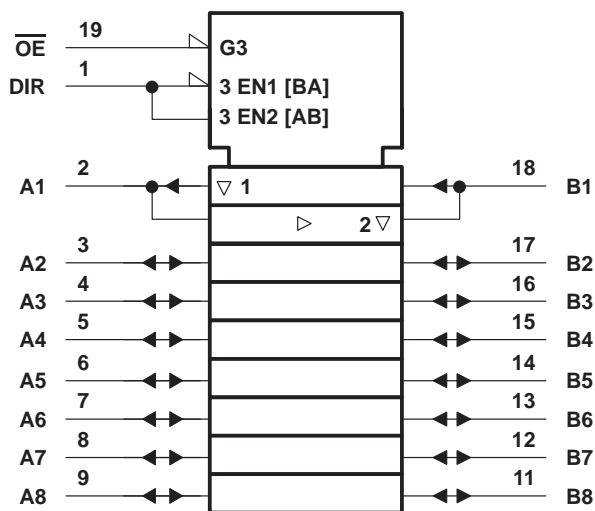

† This symbol is in accordance with ANSI/IEEE Std 91-1984 and IEC Publication 617-12.

logic diagram (positive logic)

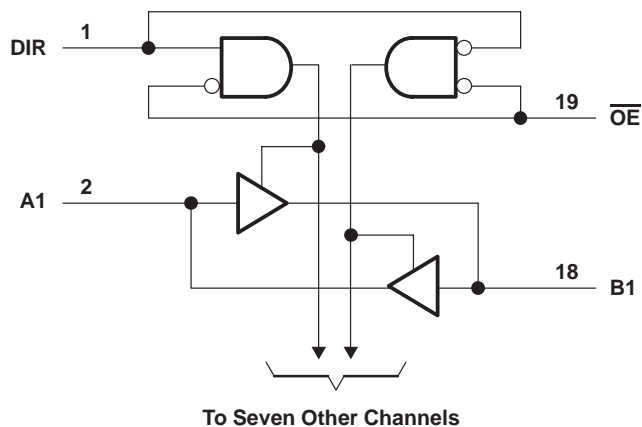

SN74LVC245A OCTAL BUS TRANSCEIVER WITH 3-STATE OUTPUTS

SCAS218I – JANUARY 1993 – REVISED JUNE 1998

absolute maximum ratings over operating free-air temperature range (unless otherwise noted)†

| | |
|-----------------------------------------------------------------------------------------------------------|----------------------------|
| Supply voltage range, V_{CC} | –0.5 V to 6.5 V |
| Input voltage range, V_I : (see Note 1) | –0.5 V to 6.5 V |
| Voltage range applied to any output in the high-impedance or power-off state, V_O (see Note 1) | –0.5 V to 6.5 V |
| Voltage range applied to any output in the high or low state, V_O (see Notes 1 and 2) | –0.5 V to $V_{CC} + 0.5$ V |
| Input clamp current, I_{IK} ($V_I < 0$) | –50 mA |
| Output clamp current, I_{OK} ($V_O < 0$) | –50 mA |
| Continuous output current, I_O | ±50 mA |
| Continuous current through V_{CC} or GND | ±100 mA |
| Package thermal impedance, θ_{JA} (see Note 3): DB package | 115°C/W |
| DW package | 97°C/W |
| PW package | 128°C/W |
| Storage temperature range, T_{stg} | –65°C to 150°C |

† Stresses beyond those listed under “absolute maximum ratings” may cause permanent damage to the device. These are stress ratings only, and functional operation of the device at these or any other conditions beyond those indicated under “recommended operating conditions” is not implied. Exposure to absolute-maximum-rated conditions for extended periods may affect device reliability.

- NOTES: 1. The input negative-voltage and output voltage ratings may be exceeded if the input and output current ratings are observed.
 2. The value of V_{CC} is provided in the recommended operating conditions table.
 3. The package thermal impedance is calculated in accordance with JESD 51.

recommended operating conditions (see Note 4)

| | | MIN | MAX | UNIT | |
|---------------------|------------------------------------|-----------------------------|----------------------|----------|----|
| V_{CC} | Supply voltage | Operating | 1.65 | 3.6 | V |
| | | Data retention only | 1.5 | | |
| V_{IH} | High-level input voltage | $V_{CC} = 1.65$ V to 1.95 V | $0.65 \times V_{CC}$ | | V |
| | | $V_{CC} = 2.3$ V to 2.7 V | 1.7 | | |
| | | $V_{CC} = 2.7$ V to 3.6 V | 2 | | |
| V_{IL} | Low-level input voltage | $V_{CC} = 1.65$ V to 1.95 V | $0.35 \times V_{CC}$ | | V |
| | | $V_{CC} = 2.3$ V to 2.7 V | 0.7 | | |
| | | $V_{CC} = 2.7$ V to 3.6 V | 0.8 | | |
| V_I | Input voltage | 0 | 5.5 | V | |
| V_O | Output voltage | High or low state | 0 | V_{CC} | V |
| | | 3 state | 0 | 5.5 | |
| I_{OH} | High-level output current | $V_{CC} = 1.65$ V | –4 | | mA |
| | | $V_{CC} = 2.3$ V | –8 | | |
| | | $V_{CC} = 2.7$ V | –12 | | |
| | | $V_{CC} = 3$ V | –24 | | |
| I_{OL} | Low-level output current | $V_{CC} = 1.65$ V | 4 | | mA |
| | | $V_{CC} = 2.3$ V | 8 | | |
| | | $V_{CC} = 2.7$ V | 12 | | |
| | | $V_{CC} = 3$ V | 24 | | |
| $\Delta t/\Delta v$ | Input transition rise or fall rate | 0 | 10 | ns/V | |
| T_A | Operating free-air temperature | –40 | 85 | °C | |

NOTE 4: All unused inputs of the device must be held at V_{CC} or GND to ensure proper device operation. Refer to the TI application report, *Implications of Slow or Floating CMOS Inputs*, literature number SCBA004.



SN74LVC245A OCTAL BUS TRANSCEIVER WITH 3-STATE OUTPUTS

SCAS218I – JANUARY 1993 – REVISED JUNE 1998

electrical characteristics over recommended operating free-air temperature range (unless otherwise noted)

| PARAMETER | | TEST CONDITIONS | V _{CC} | MIN | TYP† | MAX | UNIT |
|-------------------|----------------|------------------------------------------------------------------------------|-----------------|----------------------|------|------|------|
| V _{OH} | | I _{OH} = -100 μA | 1.65 V to 3.6 V | V _{CC} -0.2 | | | V |
| | | I _{OH} = -4 mA | 1.65 V | 1.2 | | | |
| | | I _{OH} = -8 mA | 2.3 V | 1.7 | | | |
| | | I _{OH} = -12 mA | 2.7 V | 2.2 | | | |
| | | I _{OH} = -24 mA | 3 V | 2.4 | | | |
| V _{OL} | | I _{OL} = 100 μA | 1.65 V to 3.6 V | | | 0.2 | V |
| | | I _{OL} = 4 mA | 1.65 V | | | 0.45 | |
| | | I _{OL} = 8 mA | 2.3 V | | | 0.7 | |
| | | I _{OL} = 12 mA | 2.7 V | | | 0.4 | |
| | | I _{OL} = 24 mA | 3 V | | | 0.55 | |
| I _I | Control inputs | V _I = 0 to 5.5 V | 3.6 V | | | ±5 | μA |
| I _{off} | | V _I or V _O = 5.5 V | 0 | | | ±10 | μA |
| I _{OZ} ‡ | | V _O = 0 to 5.5 V | 3.6 V | | | ±10 | μA |
| I _{CC} | | V _I = V _{CC} or GND | 3.6 V | | | 10 | μA |
| | | 3.6 V ≤ V _I ≤ 5.5 V§ | | I _O = 0 | | 10 | |
| ΔI _{CC} | | One input at V _{CC} - 0.6 V, Other inputs at V _{CC} or GND | 2.7 V to 3.6 V | | | 500 | μA |
| C _i | Control inputs | V _I = V _{CC} or GND | 3.3 V | | | 4 | pF |
| C _{io} | A or B ports | V _O = V _{CC} or GND | 3.3 V | | | 5.5 | pF |

† All typical values are at V_{CC} = 3.3 V, T_A = 25°C.

‡ For I/O ports, the parameter I_{OZ} includes the input leakage current.

§ This applies in the disabled state only.

switching characteristics over recommended operating free-air temperature range (unless otherwise noted) (see Figures 1 through 3)

| PARAMETER | FROM (INPUT) | TO (OUTPUT) | V _{CC} = 1.8 V ± 0.15 V | | V _{CC} = 2.5 V ± 0.2 V | | V _{CC} = 2.7 V | | V _{CC} = 3.3 V ± 0.3 V | | UNIT |
|----------------------|------------------------|-------------|----------------------------------|-----|---------------------------------|-----|-------------------------|-----|---------------------------------|-----|------|
| | | | MIN | MAX | MIN | MAX | MIN | MAX | MIN | MAX | |
| t _{pd} | A or B | B or A | ¶ | ¶ | ¶ | ¶ | 7.3 | 1.5 | 6.3 | ns | |
| t _{en} | $\overline{\text{OE}}$ | A or B | ¶ | ¶ | ¶ | ¶ | 9.5 | 1.5 | 8.5 | ns | |
| t _{dis} | $\overline{\text{OE}}$ | A or B | ¶ | ¶ | ¶ | ¶ | 8.5 | 1.7 | 7.5 | ns | |
| t _{sk(o)} # | | | | | | | | | 1 | ns | |

¶ This information was not available at the time of publication.

Skew between any two outputs of the same package switching in the same direction

operating characteristics, T_A = 25°C

| PARAMETER | | TEST CONDITIONS | V _{CC} = 1.8 V ± 0.15 V | V _{CC} = 2.5 V ± 0.2 V | V _{CC} = 3.3 V ± 0.3 V | UNIT |
|-----------------|-----------------------------------------------|------------------|----------------------------------|---------------------------------|---------------------------------|------|
| | | | TYP | TYP | TYP | |
| C _{pd} | Power dissipation capacitance per transceiver | Outputs enabled | ¶ | ¶ | 45 | pF |
| | | Outputs disabled | ¶ | ¶ | 2 | |

¶ This information was not available at the time of publication.



PARAMETER MEASUREMENT INFORMATION
 $V_{CC} = 1.8\text{ V} \pm 0.15\text{ V}$

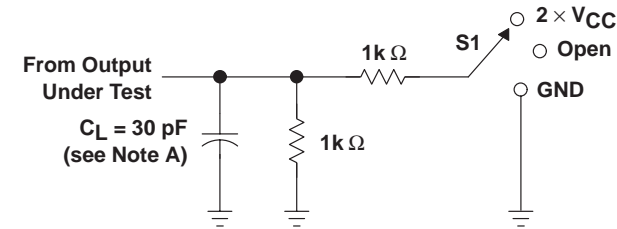

LOAD CIRCUIT

| TEST | S1 |
|-------------------|-------------------|
| t_{pd} | Open |
| t_{PLZ}/t_{PZL} | $2 \times V_{CC}$ |
| t_{PHZ}/t_{PZH} | Open |

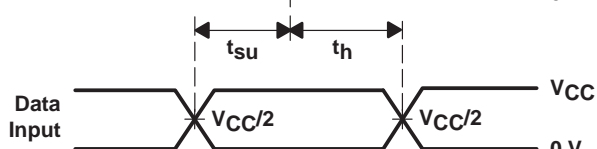

VOLTAGE WAVEFORMS
SETUP AND HOLD TIMES

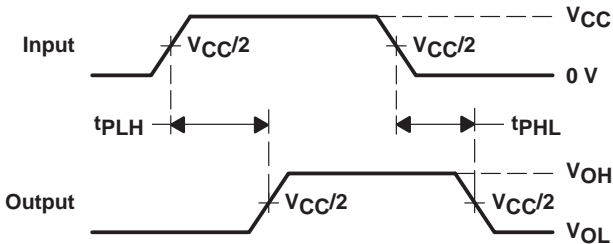

VOLTAGE WAVEFORMS
PROPAGATION DELAY TIMES

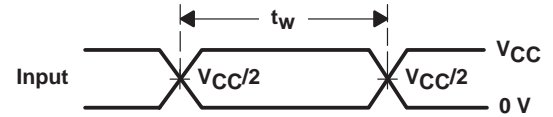

VOLTAGE WAVEFORMS
PULSE DURATION

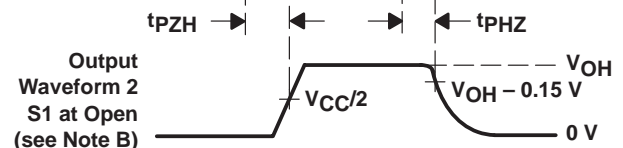
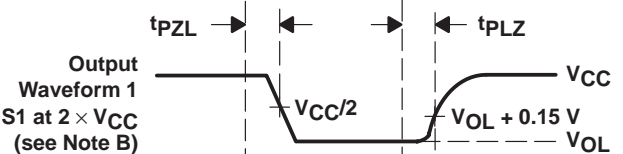
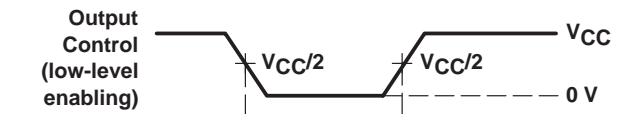

VOLTAGE WAVEFORMS
ENABLE AND DISABLE TIMES

- NOTES: A. C_L includes probe and jig capacitance.
 B. Waveform 1 is for an output with internal conditions such that the output is low except when disabled by the output control. Waveform 2 is for an output with internal conditions such that the output is high except when disabled by the output control.
 C. All input pulses are supplied by generators having the following characteristics: $PRR \leq 10\text{ MHz}$, $Z_O = 50\ \Omega$, $t_r \leq 2\text{ ns}$, $t_f \leq 2\text{ ns}$.
 D. The outputs are measured one at a time with one transition per measurement.
 E. t_{PLZ} and t_{PHZ} are the same as t_{dis} .
 F. t_{PZL} and t_{PZH} are the same as t_{en} .
 G. t_{PLH} and t_{PHL} are the same as t_{pd} .

Figure 1. Load Circuit and Voltage Waveforms

SN74LVC245A
OCTAL BUS TRANSCEIVER
WITH 3-STATE OUTPUTS

SCAS2181 – JANUARY 1993 – REVISED JUNE 1998

PARAMETER MEASUREMENT INFORMATION

$V_{CC} = 2.5 V \pm 0.2 V$

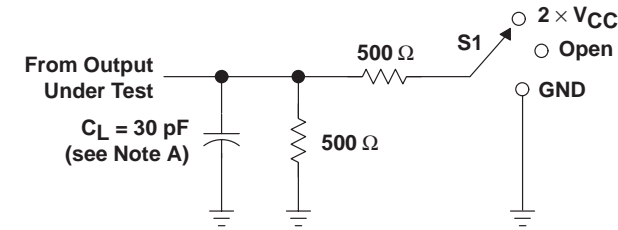

LOAD CIRCUIT

| TEST | S1 |
|-------------------|-------------------|
| t_{pd} | Open |
| t_{PLZ}/t_{PZL} | 2 $\times V_{CC}$ |
| t_{PHZ}/t_{PZH} | GND |

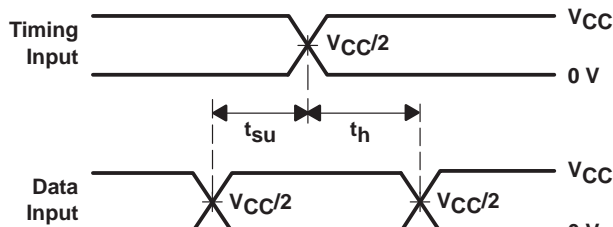

**VOLTAGE WAVEFORMS
 SETUP AND HOLD TIMES**

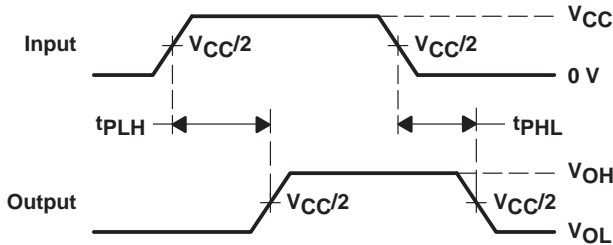

**VOLTAGE WAVEFORMS
 PROPAGATION DELAY TIMES**

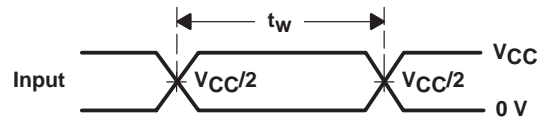

**VOLTAGE WAVEFORMS
 PULSE DURATION**

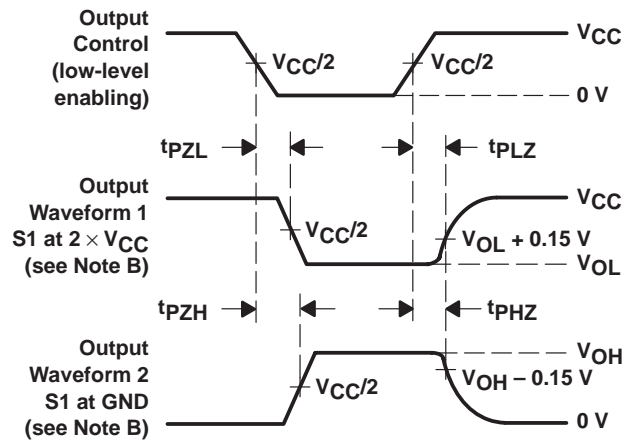

**VOLTAGE WAVEFORMS
 ENABLE AND DISABLE TIMES**

- NOTES:
- A. C_L includes probe and jig capacitance.
 - B. Waveform 1 is for an output with internal conditions such that the output is low except when disabled by the output control. Waveform 2 is for an output with internal conditions such that the output is high except when disabled by the output control.
 - C. All input pulses are supplied by generators having the following characteristics: $PRR \leq 10 \text{ MHz}$, $Z_O = 50 \Omega$, $t_r \leq 2 \text{ ns}$, $t_f \leq 2 \text{ ns}$.
 - D. The outputs are measured one at a time with one transition per measurement.
 - E. t_{PLZ} and t_{PHZ} are the same as t_{dis} .
 - F. t_{PZL} and t_{PZH} are the same as t_{en} .
 - G. t_{PLH} and t_{PHL} are the same as t_{pd} .

Figure 2. Load Circuit and Voltage Waveforms

PARAMETER MEASUREMENT INFORMATION
 $V_{CC} = 2.7\text{ V AND } 3.3\text{ V} \pm 0.3\text{ V}$

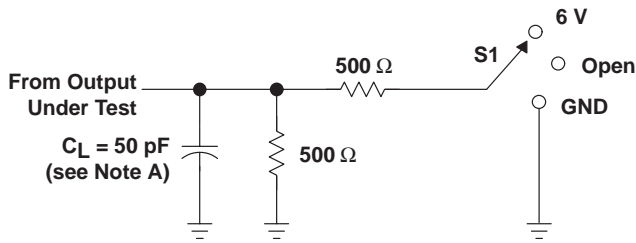

LOAD CIRCUIT

| TEST | S1 |
|-------------------|------|
| t_{pd} | Open |
| t_{PLZ}/t_{PZL} | 6 V |
| t_{PHZ}/t_{PZH} | GND |

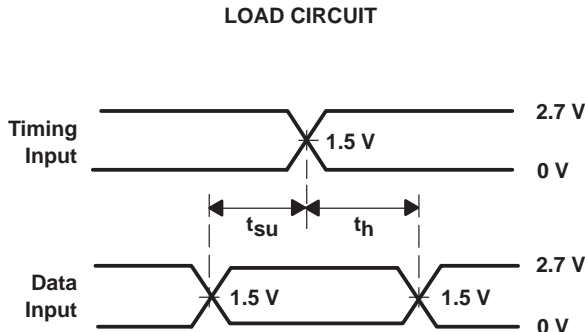

**VOLTAGE WAVEFORMS
SETUP AND HOLD TIMES**

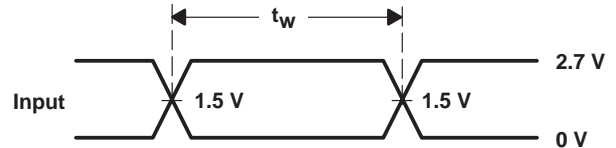

**VOLTAGE WAVEFORMS
PULSE DURATION**

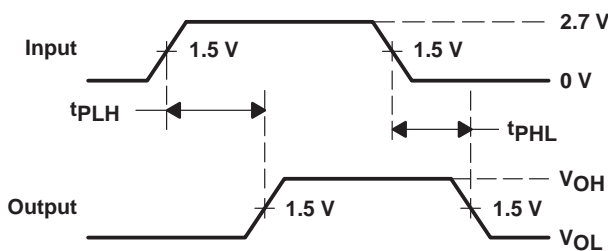

**VOLTAGE WAVEFORMS
PROPAGATION DELAY TIMES**

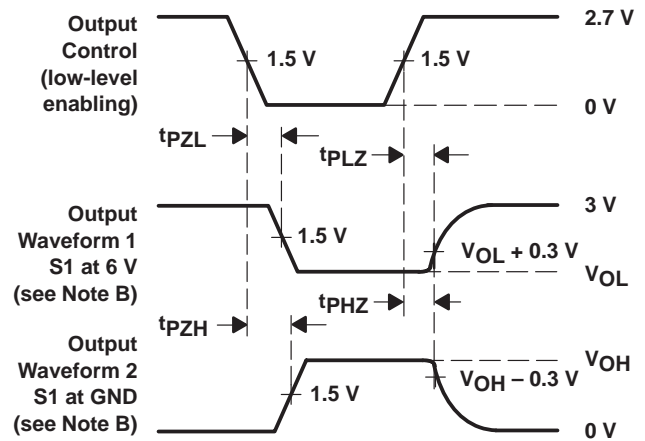

**VOLTAGE WAVEFORMS
ENABLE AND DISABLE TIMES**

- NOTES:
- C_L includes probe and jig capacitance.
 - Waveform 1 is for an output with internal conditions such that the output is low except when disabled by the output control. Waveform 2 is for an output with internal conditions such that the output is high except when disabled by the output control.
 - All input pulses are supplied by generators having the following characteristics: $PRR \leq 10\text{ MHz}$, $Z_O = 50\ \Omega$, $t_r \leq 2.5\text{ ns}$, $t_f \leq 2.5\text{ ns}$.
 - The outputs are measured one at a time with one transition per measurement.
 - t_{PLZ} and t_{PHZ} are the same as t_{dis} .
 - t_{PZL} and t_{PZH} are the same as t_{en} .
 - t_{PLH} and t_{PHL} are the same as t_{pd} .

Figure 3. Load Circuit and Voltage Waveforms

IMPORTANT NOTICE

Texas Instruments and its subsidiaries (TI) reserve the right to make changes to their products or to discontinue any product or service without notice, and advise customers to obtain the latest version of relevant information to verify, before placing orders, that information being relied on is current and complete. All products are sold subject to the terms and conditions of sale supplied at the time of order acknowledgement, including those pertaining to warranty, patent infringement, and limitation of liability.

TI warrants performance of its semiconductor products to the specifications applicable at the time of sale in accordance with TI's standard warranty. Testing and other quality control techniques are utilized to the extent TI deems necessary to support this warranty. Specific testing of all parameters of each device is not necessarily performed, except those mandated by government requirements.

CERTAIN APPLICATIONS USING SEMICONDUCTOR PRODUCTS MAY INVOLVE POTENTIAL RISKS OF DEATH, PERSONAL INJURY, OR SEVERE PROPERTY OR ENVIRONMENTAL DAMAGE ("CRITICAL APPLICATIONS"). TI SEMICONDUCTOR PRODUCTS ARE NOT DESIGNED, AUTHORIZED, OR WARRANTED TO BE SUITABLE FOR USE IN LIFE-SUPPORT DEVICES OR SYSTEMS OR OTHER CRITICAL APPLICATIONS. INCLUSION OF TI PRODUCTS IN SUCH APPLICATIONS IS UNDERSTOOD TO BE FULLY AT THE CUSTOMER'S RISK.

In order to minimize risks associated with the customer's applications, adequate design and operating safeguards must be provided by the customer to minimize inherent or procedural hazards.

TI assumes no liability for applications assistance or customer product design. TI does not warrant or represent that any license, either express or implied, is granted under any patent right, copyright, mask work right, or other intellectual property right of TI covering or relating to any combination, machine, or process in which such semiconductor products or services might be or are used. TI's publication of information regarding any third party's products or services does not constitute TI's approval, warranty or endorsement thereof.

This datasheet has been downloaded from:

www.DatasheetCatalog.com

Datasheets for electronic components.

Texas Instruments

<http://www.ti.com>

This file is the datasheet for the following electronic components:

74LVC245 - <http://www.ti.com/product/74lvc245?HQS=TI-null-null-dscatalog-df-pf-null-ww>



LittleDiode supplies new, hard to find or obsolete electronic components and semiconductors all over the world.

With over two million different components listed you are sure to find the part you need.

Feel free to visit us today at our online store:

LittleDiode.com

Looking forward to providing you with the best possible service.