

HA17904 Series

Dual Operational Amplifier

HITACHI

ADE-204-046 (Z)
Rev. 0
Dec. 2000

Description

HA17904 is dual operational amplifier which, provide internal phase compensation and high gain, and mono power source operation is possible. It can be widely applied to control equipment and to general use.

Features

- Wide range of operating supply voltage and mono power source operation is possible.
- Wide range of common mode input voltage possible to operate with an input around 0V, and output around 0V is available.
- Frequency characteristics and input bias current are temperature compensated.

Ordering Information

Type No.	Application	Package
HA17904PSJ	Car use	DP-8
HA17904FPJ	Car use	FP-8D
HA17904FPK	Car use	
HA17904PS	Industrial use	DP-8
HA17904FP	Industrial use	FP-8D

Pin Arrangement

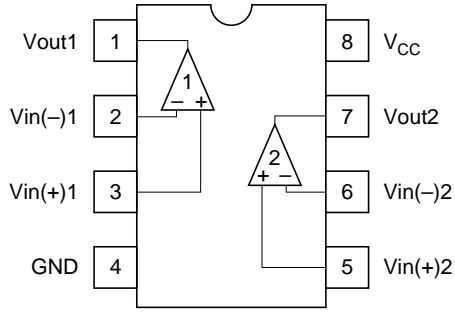

(Top View)

Circuit Schematic (1/2)

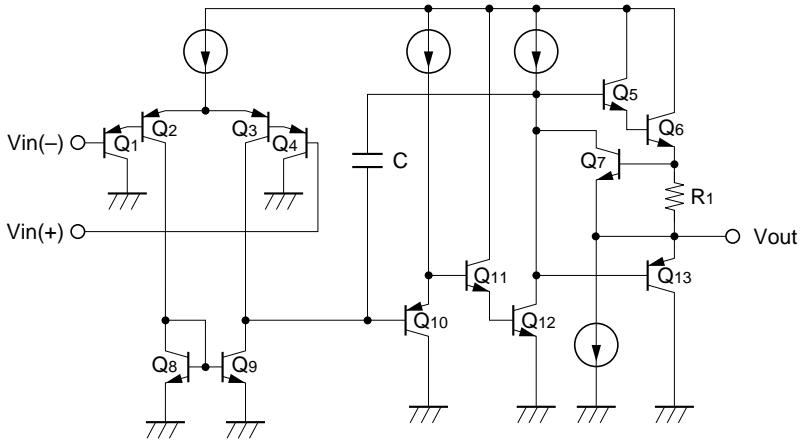

Absolute Maximum Ratings (Ta = 25°C)

Item	Symbol	Ratings					Unit
		HA17904PS	HA17904FP	HA17904PSJ	HA17904FPJ	HA17904FPK	
Supply voltage	V_{CC}	32	32	32	32	32	V
Output sink current	$I_{O\ sink}$	50	50	50	50	50	mA
Common-mode input voltage	V_{CM}	-0.3 to V_{CC}	-0.3 to V_{CC}	-0.3 to V_{CC}	-0.3 to V_{CC}	-0.3 to V_{CC}	V
Common-mode differential voltage	$V_{IN(diff)}$	$\pm V_{CC}$	$\pm V_{CC}$	$\pm V_{CC}$	$\pm V_{CC}$	$\pm V_{CC}$	V
Power dissipation	P_T	570* ¹	385* ²	570* ¹	385* ²	385* ²	mW
Operating temperature range	T_{opr}	-20 to +75	-20 to +75	-40 to +85	-40 to +85	-40 to +125	°C
Storage temperature range	T_{stg}	-55 to +125	-55 to +125	-55 to +125	-55 to +125	-55 to +150	°C

- Notes: 1. These are the allowable values up to Ta = 55 °C. Derate by 8.3mW/°C above that temperature.
 2. These are the allowable values up to Ta = 45 °C mounting on 30% wiring density glass epoxy board. Derate by 7.14mW/°C above that temperature.

Electrical Characteristics 1 ($V_{CC} = +15V$, $T_a = 25^\circ C$)

Item	Symbol	Min	Typ	Max	Unit	Test Conditions
Input offset voltage	V_{IO}	—	3	7	mV	$V_{CM} = 7.5V$, $R_S = 50\Omega$, $R_f = 50k\Omega$
Input offset current	I_{IO}	—	5	50	nA	$V_{CM} = 7.5V$, $I_{IO} = I_{I(+)} - I_{I(-)} $
Input bias current	I_{IB}	—	30	250	nA	$V_{CM} = 7.5V$
Power source rejection ratio	PSRR	—	93	—	dB	$R_S = 1k\Omega$, $R_f = 100k\Omega$
Voltage gain	A_{VD}	75	90	—	dB	$R_L = \infty$, $R_S = 1k\Omega$, $R_f = 100k\Omega$
Common mode rejection ratio	CMR	—	80	—	dB	$R_S = 50\Omega$, $R_f = 5k\Omega$
Common mode input voltage range	$V_{CM(+)}$	13.5	—	—	V	$R_S = 1k\Omega$, $R_f = 100k\Omega$
	$V_{CM(-)}$	—	—	-0.3	V	$R_S = 1k\Omega$, $R_f = 100k\Omega$
Peak-to-peak output voltage	V_{op-p}	—	13.6	—	V	$f = 100Hz$, $R_L = 20k\Omega$, $R_S = 1k\Omega$, $R_f = 100k\Omega$
Output source current	$I_{osource}$	20	40	—	mA	$V_{IN}^+ = 1V$, $V_{IN}^- = 0V$, $V_{OH} = 10V$
Output sink current	I_{osink}	10	20	—	mA	$V_{IN}^- = 1V$, $V_{IN}^+ = 0V$, $V_{OL} = 2.5V$
Output sink current	I_{osink}	15	50	—	μA	$V_{IN}^- = 1V$, $V_{IN}^+ = 0V$, $V_{out} = 200mV$
Supply current	I_{CC}	—	0.8	2	mA	$V_{IN} = GND$, $R_L = \infty$
Slew rate	SR	—	0.2	—	V/ μs	$R_L = \infty$, $V_{CM} = 7.5V$, $f = 1.5kHz$
Channel separation	CS	—	120	—	dB	$f = 1kHz$

Electrical Characteristics 2 ($V_{CC} = +15V$, $T_a = -40$ to $+125^\circ C$)

Item	Symbol	Min	Typ	Max	Unit	Test Conditions
Input offset voltage	V_{IO}	—	—	7	mV	$V_{CM} = 7.5V$, $R_S = 50\Omega$, $R_L = 50k\Omega$
Input offset current	I_{IO}	—	—	200	nA	$V_{CM} = 7.5V$, $I_{IO} = I_{I(+)} - I_{I(-)} $
Input bias current	I_{IB}	—	—	500	nA	$V_{CM} = 7.5V$
Common mode input voltage range	V_{CM}	0	—	13.0	V	$R_S = 1k\Omega$, $R_f = 100k\Omega$
Supply current	I_{CC}	—	—	4	mA	$V_{IN} = GND$, $R_L = \infty$

Note: As for the characteristic curve, refer to HA17904FPK.

Characteristic Curves

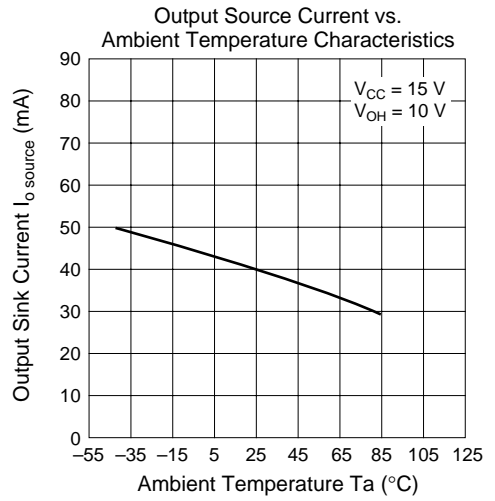
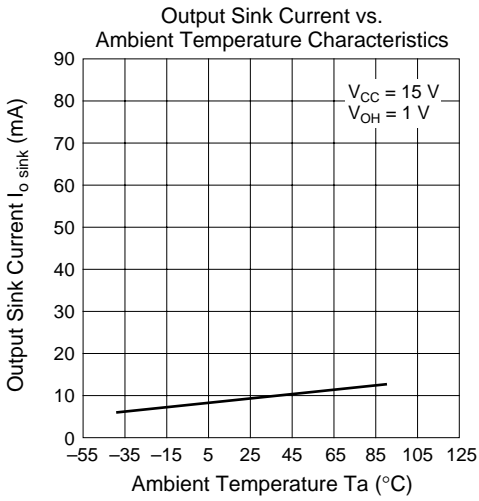
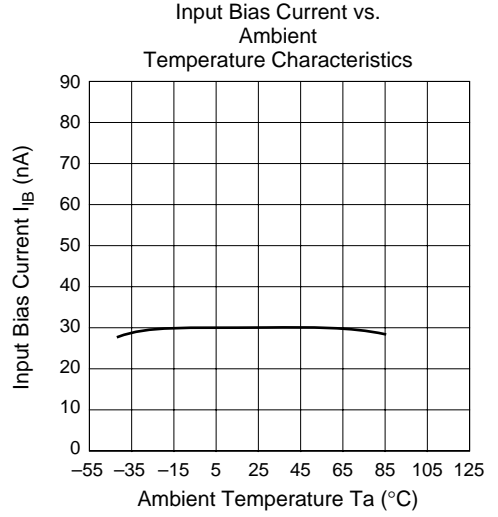
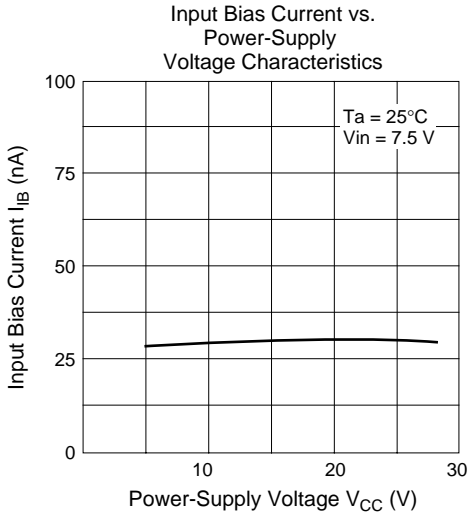

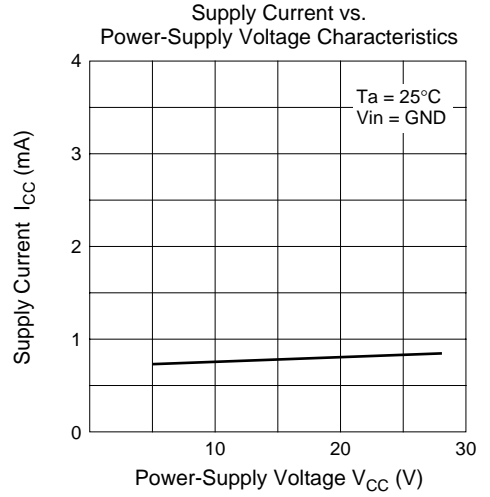
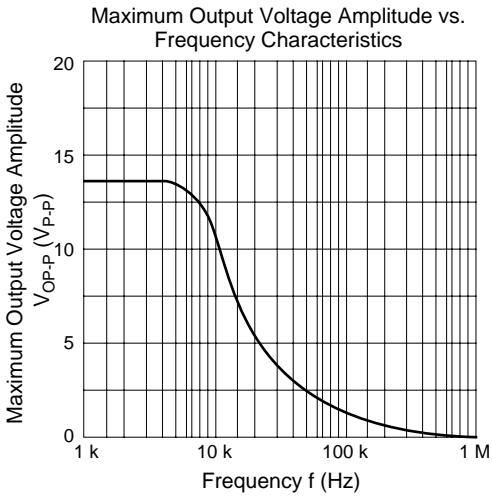
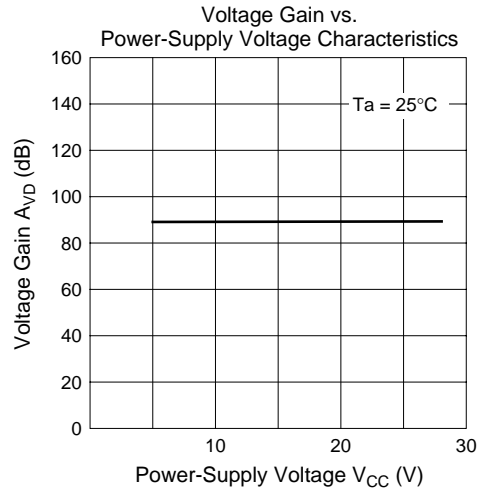
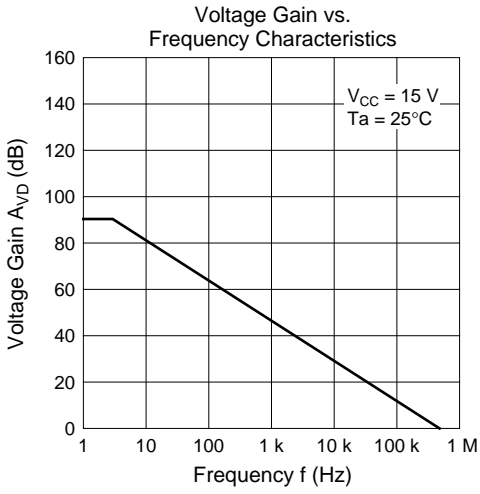

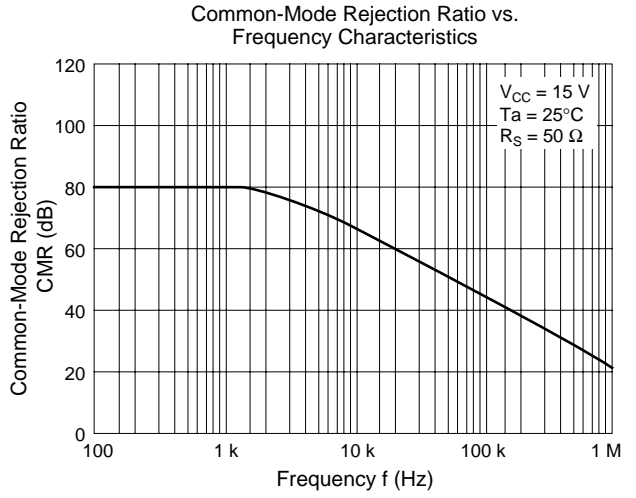
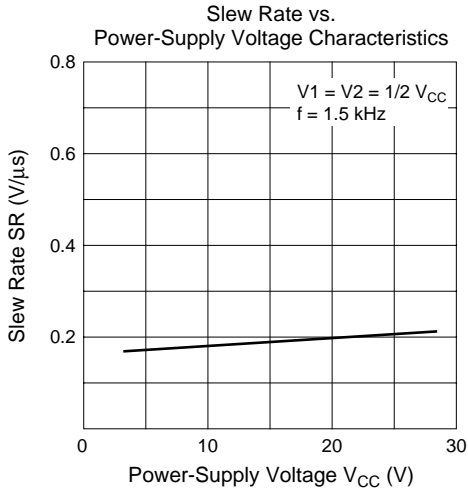

Package Dimensions

Unit: mm

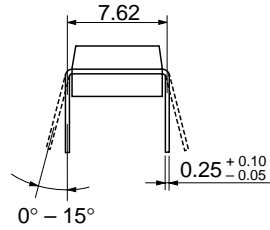
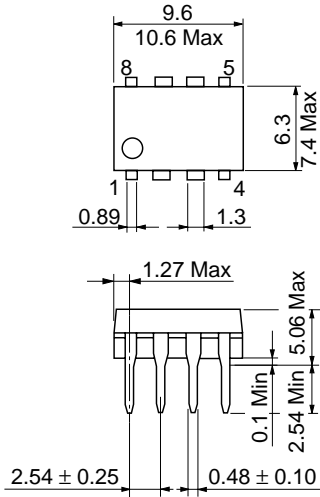

Hitachi Code	DP-8
JEDEC	Conforms
EIAJ	Conforms
Mass (reference value)	0.54 g

Unit: mm

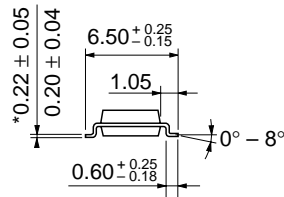
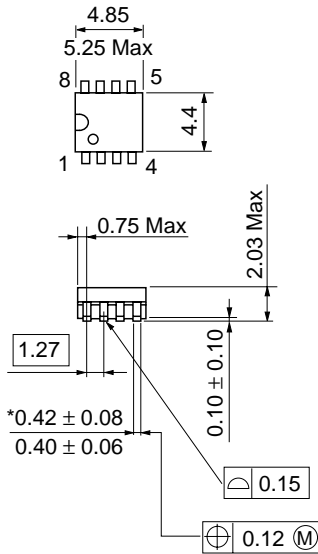

Hitachi Code	FP-8D
JEDEC	—
EIAJ	Conforms
Mass (reference value)	0.10 g

*Dimension including the plating thickness
Base material dimension

Cautions

1. Hitachi neither warrants nor grants licenses of any rights of Hitachi's or any third party's patent, copyright, trademark, or other intellectual property rights for information contained in this document. Hitachi bears no responsibility for problems that may arise with third party's rights, including intellectual property rights, in connection with use of the information contained in this document.
2. Products and product specifications may be subject to change without notice. Confirm that you have received the latest product standards or specifications before final design, purchase or use.
3. Hitachi makes every attempt to ensure that its products are of high quality and reliability. However, contact Hitachi's sales office before using the product in an application that demands especially high quality and reliability or where its failure or malfunction may directly threaten human life or cause risk of bodily injury, such as aerospace, aeronautics, nuclear power, combustion control, transportation, traffic, safety equipment or medical equipment for life support.
4. Design your application so that the product is used within the ranges guaranteed by Hitachi particularly for maximum rating, operating supply voltage range, heat radiation characteristics, installation conditions and other characteristics. Hitachi bears no responsibility for failure or damage when used beyond the guaranteed ranges. Even within the guaranteed ranges, consider normally foreseeable failure rates or failure modes in semiconductor devices and employ systemic measures such as fail-safes, so that the equipment incorporating Hitachi product does not cause bodily injury, fire or other consequential damage due to operation of the Hitachi product.
5. This product is not designed to be radiation resistant.
6. No one is permitted to reproduce or duplicate, in any form, the whole or part of this document without written approval from Hitachi.
7. Contact Hitachi's sales office for any questions regarding this document or Hitachi semiconductor products.

HITACHI

Hitachi, Ltd.

Semiconductor & Integrated Circuits.
 Nippon Bldg., 2-6-2, Ohte-machi, Chiyoda-ku, Tokyo 100-0004, Japan
 Tel: Tokyo (03) 3270-2111 Fax: (03) 3270-5109

URL NorthAmerica : <http://semiconductor.hitachi.com/>
 Europe : <http://www.hitachi-eu.com/hel/ecg>
 Asia : <http://sicapac.hitachi-asia.com>
 Japan : <http://www.hitachi.co.jp/Sicd/indx.htm>

For further information write to:

Hitachi Semiconductor
 (America) Inc.
 179 East Tasman Drive,
 San Jose, CA 95134
 Tel: <1> (408) 433-1990
 Fax: <1> (408) 433-0223

Hitachi Europe GmbH
 Electronic Components Group
 Dornacher Straße 3
 D-85622 Feldkirchen, Munich
 Germany
 Tel: <49> (89) 9 9180-0
 Fax: <49> (89) 9 29 30 00

Hitachi Europe Ltd.
 Electronic Components Group.
 Whitebrook Park
 Lower Cookham Road
 Maidenhead
 Berkshire SL6 8YA, United Kingdom
 Tel: <44> (1628) 585000
 Fax: <44> (1628) 585160

Hitachi Asia Ltd.
 Hitachi Tower
 16 Collyer Quay #20-00,
 Singapore 049318
 Tel: <65>-538-6533/538-8577
 Fax : <65>-538-6933/538-3877
 URL : <http://www.hitachi.com.sg>

Hitachi Asia Ltd.
 (Taipei Branch Office)
 4/F, No. 167, Tun Hwa North Road,
 Hung-Kuo Building,
 Taipei (105), Taiwan
 Tel: <886>-(2)-2718-3666
 Fax : <886>-(2)-2718-8180
 Telex : 23222 HAS-TP
 URL : <http://www.hitachi.com.tw>

Hitachi Asia (Hong Kong) Ltd.
 Group III (Electronic Components)
 7/F., North Tower,
 World Finance Centre,
 Harbour City, Canton Road
 Tsim Sha Tsui, Kowloon,
 Hong Kong
 Tel : <852>-(2)-735-9218
 Fax : <852>-(2)-730-0281
 URL : <http://www.hitachi.com.hk>

Copyright © Hitachi, Ltd., 2000. All rights reserved. Printed in Japan.
 Colophon 2.0



LittleDiode supplies new, hard to find or obsolete electronic components and semiconductors all over the world.

With over two million different components listed you are sure to find the part you need.

Feel free to visit us today at our online store:

LittleDiode.com

Looking forward to providing you with the best possible service.