

HSR312

HSR312L

HSR412

HSR412L

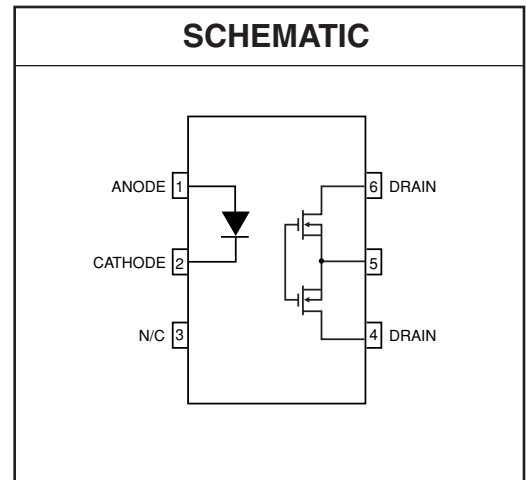
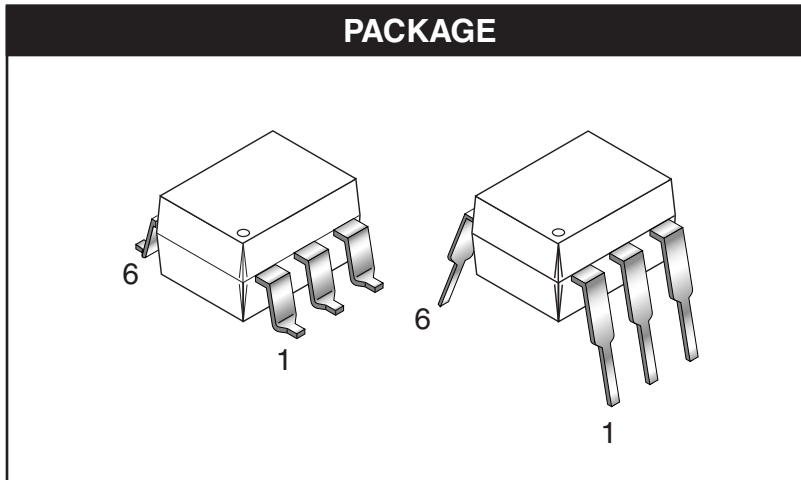

DESCRIPTION

The HSR312 and HSR412 devices consist of a AlGaAs infrared emitting diode optically coupled to a power MOSFET detector which is driven by a photovoltaic generator. The devices are housed in a 6-pin dual-in-line package. The HSR312L and HSR412L employ an active current limit circuitry enabling the device to withstand current surge transients.

FEATURES

- 4,000 VRMS Isolation
- Wide operating voltage range
 - 250 V (HSR312, HSR312L)
 - 400 V (HSR412, HSR412L)
- Solid-State Reliability
- Bounce-Free Operation
- 4000 V ESD Rating (HBM)
- UL, CSA and BABT approval pending

APPLICATIONS

- On/Off Hook Switch
- Dial Out Relay
- General Switching
- Replacement for Mechanical Relays
- Ring Injection Relay
- Ground Start

ABSOLUTE MAXIMUM RATINGS ($T_A = 25^\circ\text{C}$ unless otherwise noted)				
Parameters	Symbol	Device	Value	Units
TOTAL DEVICE				
Storage Temperature	T_{STG}	All	-40 to +100	$^\circ\text{C}$
Operating Temperature	T_{OPR}	All	-40 to +85	$^\circ\text{C}$
Lead Solder Temperature	T_{SOL}	All	260 for 10 sec	$^\circ\text{C}$
Isolation Surge Voltage	V_{ISO}	All	4000	Vac(RMS)
Maximum Input/Output Capacitance	C_{IO}	All	1.0	pF
Maximum Input/Output Resistance	R_{IO}	All	10^{12}	Ω

HSR312

HSR312L

HSR412

HSR412L

ELECTRICAL CHARACTERISTICS ($T_A = -40^\circ\text{C}$ to $+85^\circ\text{C}$ Unless otherwise specified)

INPUT CHARACTERISTICS

Parameters/Test Conditions	Connection	Symbol	Limit	HSR312	HSR312L	HSR412	HSR412L	Units
Control Current	Series or Parallel	$I_{F(ON)}$	Max	2.0	2.0	3.0	3.0	mA
Control Current for Off-State Resistance	Series or Parallel	$I_{F(OFF)}$	Min	0.4	0.4	0.4	0.4	mA
Control Current Range	Series or Parallel	I_F	Min	2.0	2.0	3.0	3.0	mA
			Max	25	25	25	25	
Reverse Voltage	Series or Parallel	V_R	Min	7	7	7	7	V
Forward Voltage ($I_F=10$ mA)	Series or Parallel	V_F	Max	1.6	1.6	1.6	1.6	V

OUTPUT CHARACTERISTICS

Parameters / Test Conditions	Connection	Symbol	Limit	HSR312	HSR312L	HSR412	HSR412L	Units
Operating Voltage Range	Series or Parallel	V_{OPR}	Max	250	250	400	400	V_{DC} or $V_{AC(PEAK)}$
Load Current $T_A = +40^\circ\text{C}$, 5mA control (see fig. 1 & 2)	Series	I_L	Max	190	170	140	120	mA
	Parallel		Max	320	300	210	200	
On-State Resistance $T_A = 25^\circ\text{C}$, 50mA pulsed load, 5mA control	Series	R_{ON}	Max	10	15	27	35	Ω
	Parallel		Max	3	4.25	7	9	
Off-State Leakage Current $T_A = 25^\circ\text{C}$, $\pm 250\text{V}$ for HSR312/L, $\pm 400\text{V}$ for HSR412/L	Series or Parallel	—	Max	1.0	1.0	1.0	1.0	μA
Current Limit $T_A = +25^\circ\text{C}$, 5mA control	Series	I_{LMT}	Min	N/A	190	N/A	130	mA
			Max	N/A	300	N/A	220	
	Parallel		Min	N/A	330	N/A	260	
			Max	N/A	560	N/A	440	
Turn-On Time $T_A = +25^\circ\text{C}$ for 50mA, 100VDC load, 5mA control	Series or Parallel	T_{ON}	Max	3.0	3.0	2.0	2.0	mS
Turn-Off Time $T_A = +25^\circ\text{C}$ for 50mA, 100VDC load, 5mA control	Series or Parallel	T_{OFF}	Max	0.5	0.5	0.5	0.5	mS
Thermal Offset Voltage 5mA control	Series or Parallel	—	Max	N/A	N/A	0.5	0.5	mV
Output Capacitance $5V_{DC}$	Series or Parallel	C_O	Max	50	50	12	12	pF

ISOLATION CHARACTERISTICS

Characteristics	Test Conditions	Symbol	Limit	HSR312	HSR312L	HSR412	HSR412L	Units
Input-Output Isolation Voltage		V_{ISO}	Max	4000	4000	4000	4000	V

HSR312

HSR312L

HSR412

HSR412L

Figure 1. Forward Current vs. Forward Voltage

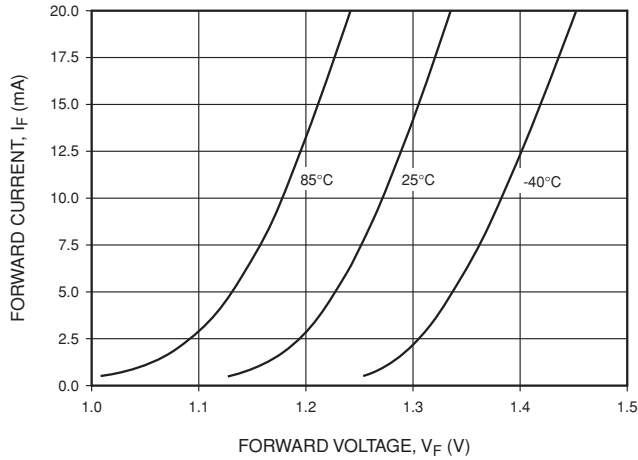

Figure 2. Normalized on Resistance vs. Ambient Temperature

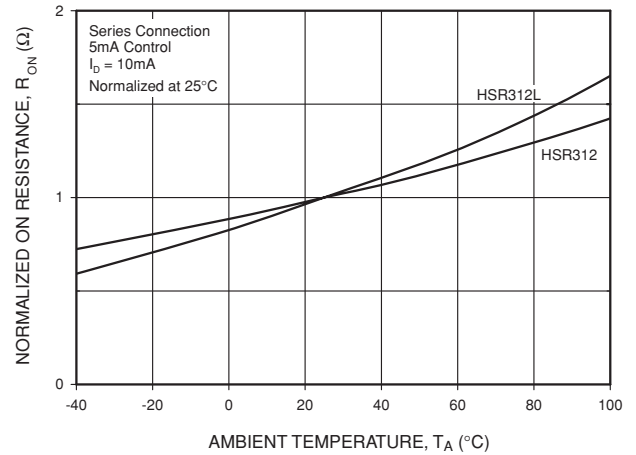

Figure 3. Normalized on Resistance vs. Ambient Temperature

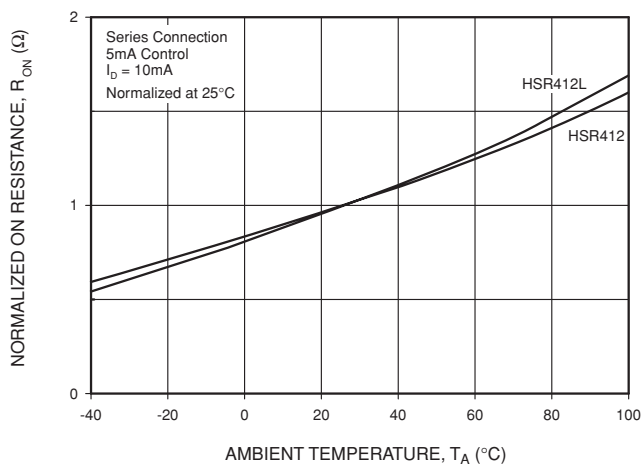

Figure 4. Load Current vs. Voltage Drop

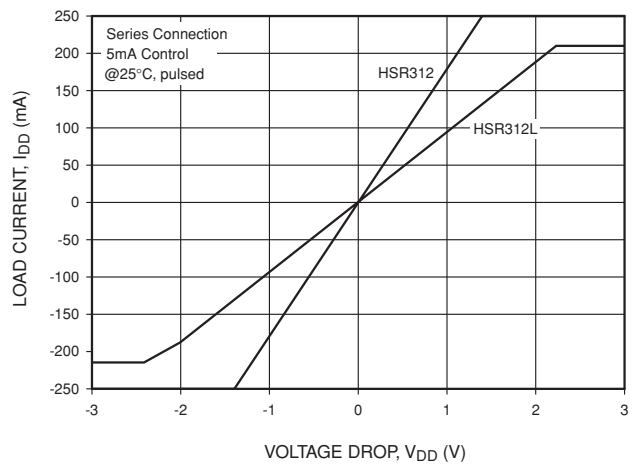

Figure 5. Load Current vs. Voltage Drop

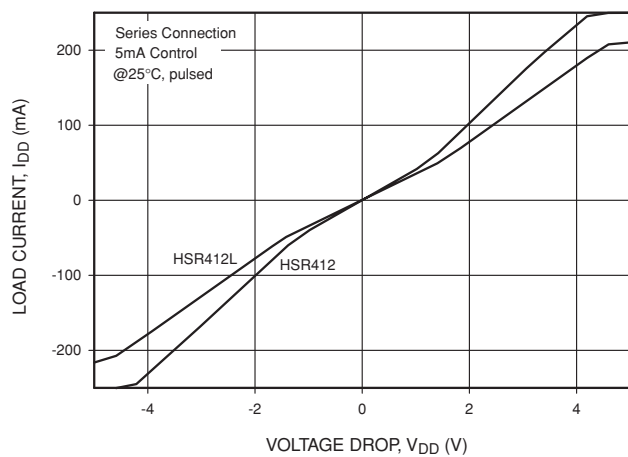
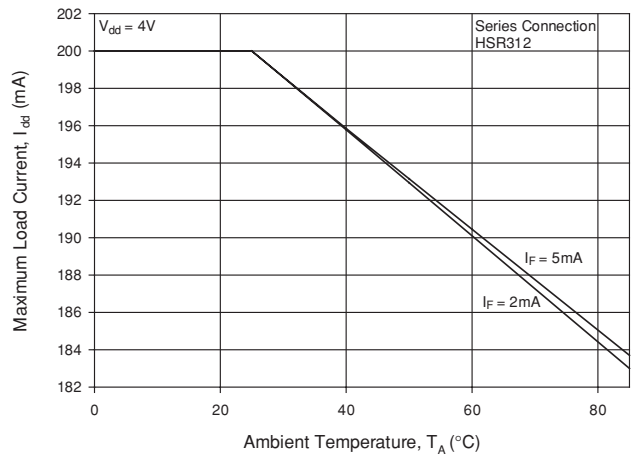

Figure 6. Maximum Load Current Vs Ambient Temperature



HSR312

HSR312L

HSR412

HSR412L

Figure 7. Maximum Load Current Vs Ambient Temperature

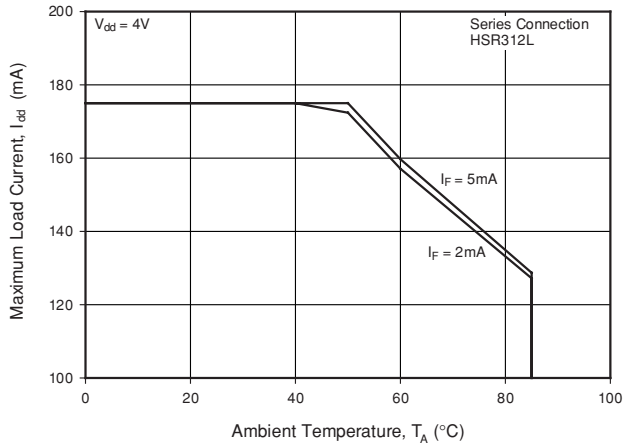

Figure 8. Maximum Load Current Vs Ambient Temperature

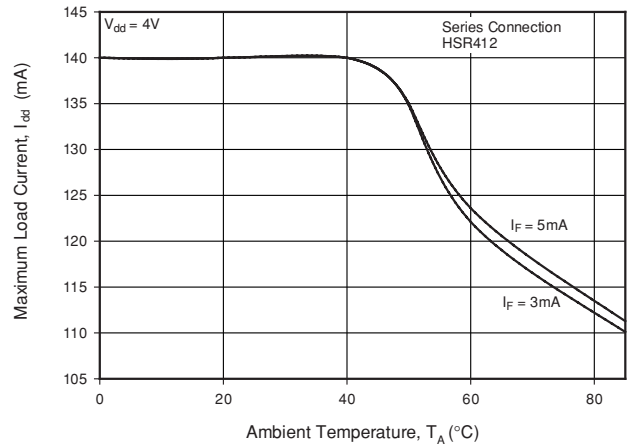

Figure 9. Maximum Load Current Vs Ambient Temperature

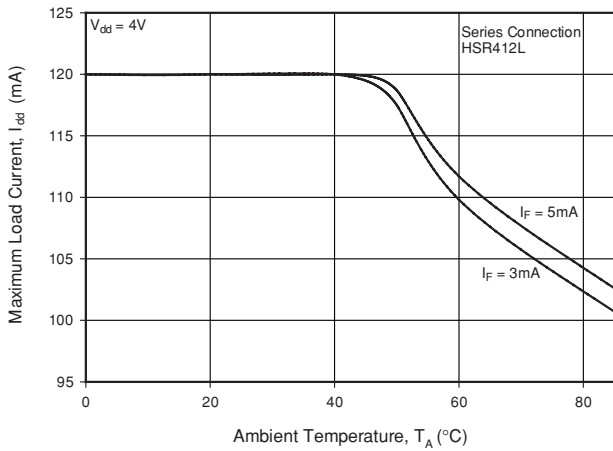

Figure 10. Off State Current vs. Ambient Temperature

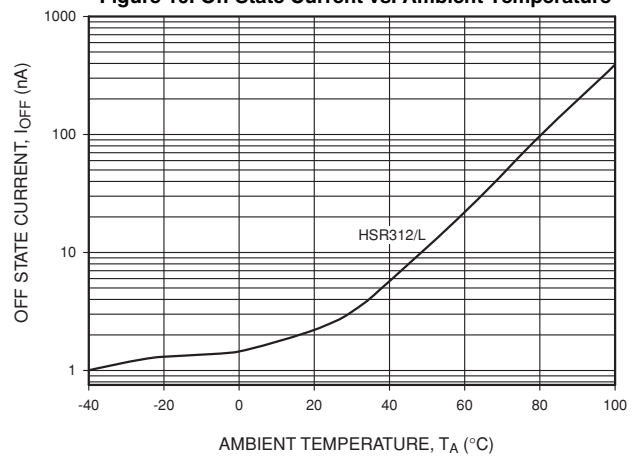

Figure 11. Off State Current vs. Ambient Temperature

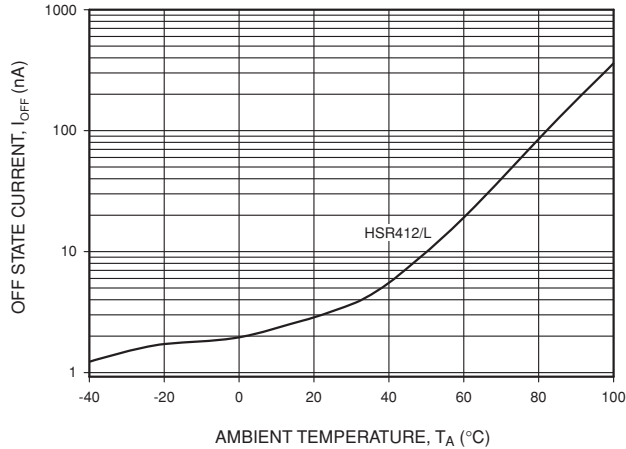
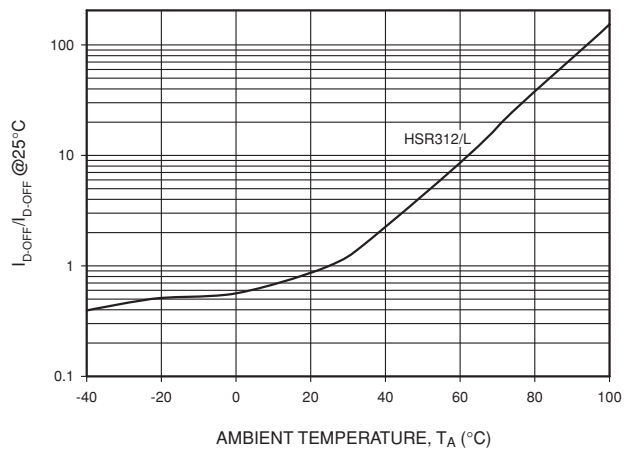

Figure 12. Normalized Off State Leakage vs. Ambient Temperature



HSR312

HSR312L

HSR412

HSR412L

Figure 13. Normalized Off State Leakage vs. Ambient Temperature

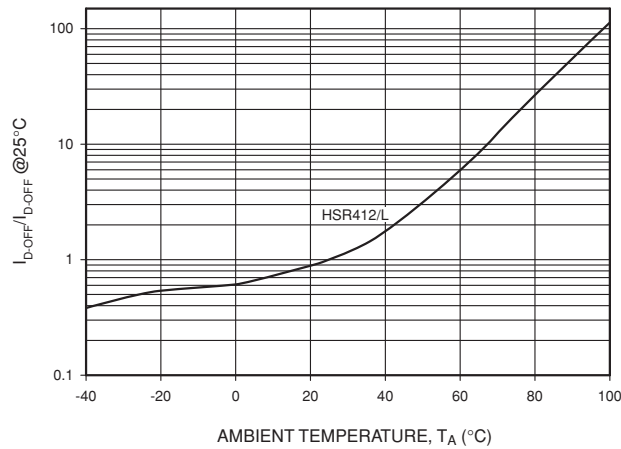

Series Connection

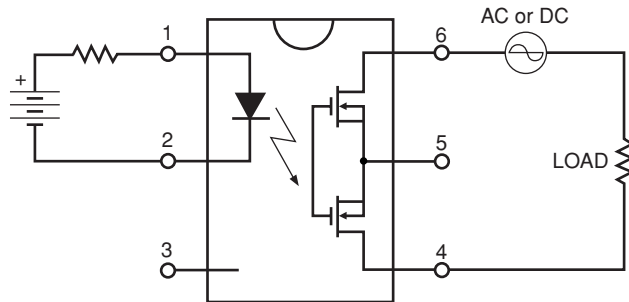

Parallel Connection

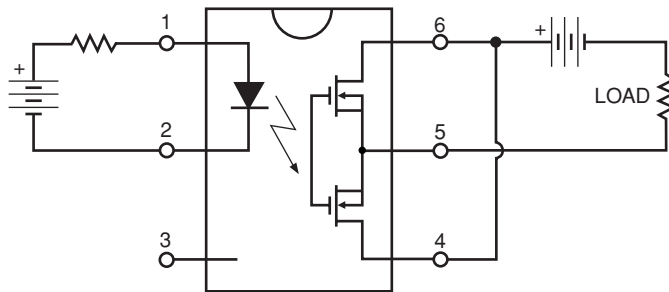

HSR312

HSR312L

HSR412

HSR412L

Package Dimensions (Through Hole)

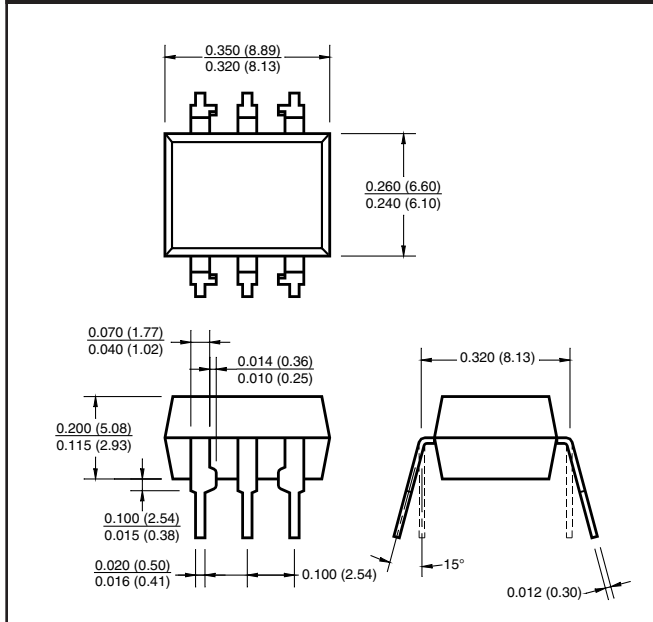

Package Dimensions (Surface Mount)

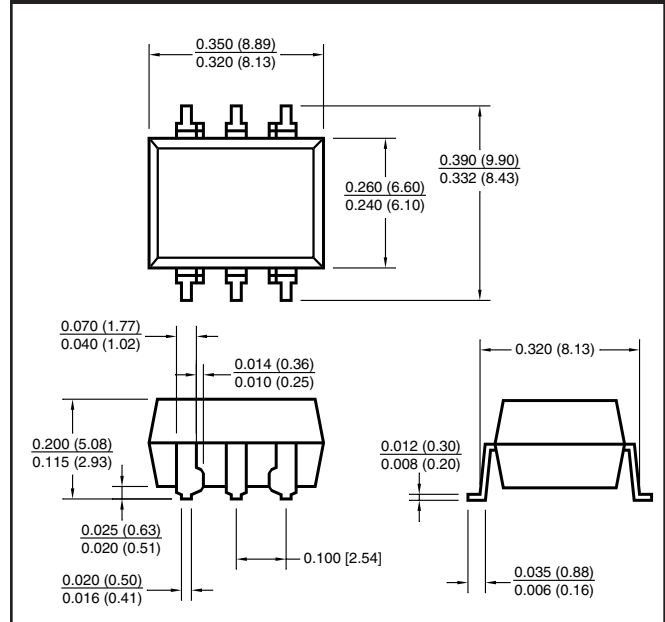

**Recommended Pad Layout for
Surface Mount Leadform**

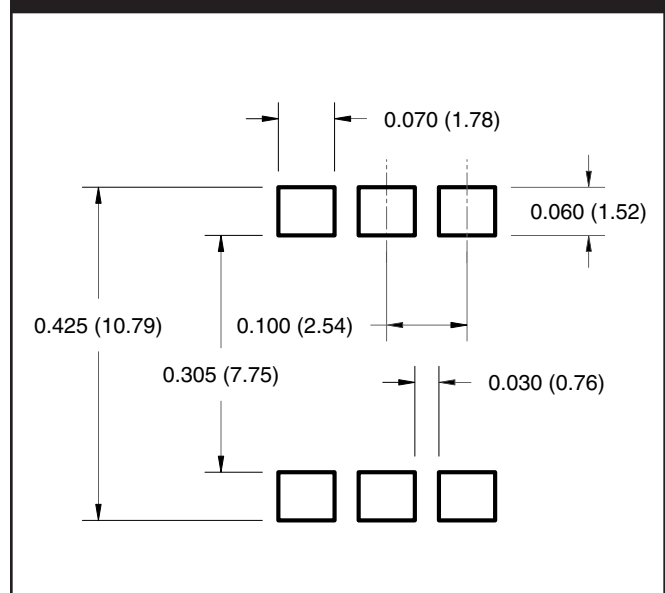

NOTE

All dimensions are in inches (millimeters)

HSR312

HSR312L

HSR412

HSR412L

ORDERING INFORMATION

Option	Order Entry Identifier	Description
S	S	Surface Mount Lead Bend
SR2	SR2	Surface Mount; Tape and reel

Carrier Tape Specifications ("D" Tapin Orientation)

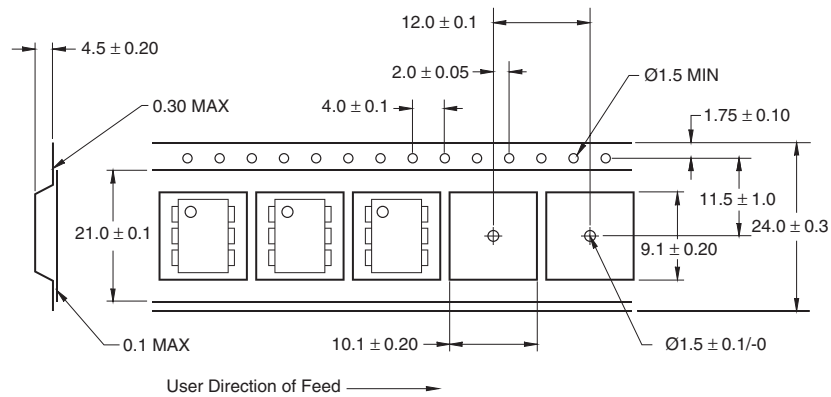

NOTE

All dimensions are in inches (millimeters)

Reflow Profile

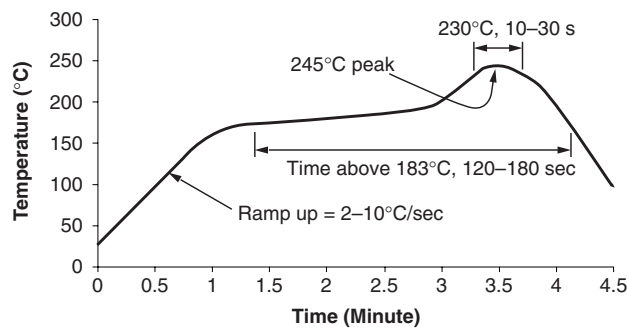

- Peak reflow temperature: 245°C (package surface temperature)
- Time of temperature higher than 183°C for 120–180 seconds
- One time soldering reflow is recommended

HSR312

HSR312L

HSR412

HSR412L

DISCLAIMER

FAIRCHILD SEMICONDUCTOR RESERVES THE RIGHT TO MAKE CHANGES WITHOUT FURTHER NOTICE TO ANY PRODUCTS HEREIN TO IMPROVE RELIABILITY, FUNCTION OR DESIGN. FAIRCHILD DOES NOT ASSUME ANY LIABILITY ARISING OUT OF THE APPLICATION OR USE OF ANY PRODUCT OR CIRCUIT DESCRIBED HEREIN; NEITHER DOES IT CONVEY ANY LICENSE UNDER ITS PATENT RIGHTS, NOR THE RIGHTS OF OTHERS.

LIFE SUPPORT POLICY

FAIRCHILD'S PRODUCTS ARE NOT AUTHORIZED FOR USE AS CRITICAL COMPONENTS IN LIFE SUPPORT DEVICES OR SYSTEMS WITHOUT THE EXPRESS WRITTEN APPROVAL OF THE PRESIDENT OF FAIRCHILD SEMICONDUCTOR CORPORATION. As used herein:

1. Life support devices or systems are devices or systems which, (a) are intended for surgical implant into the body, or (b) support or sustain life, and (c) whose failure to perform when properly used in accordance with instructions for use provided in the labeling, can be reasonably expected to result in a significant injury of the user.
2. A critical component in any component of a life support device or system whose failure to perform can be reasonably expected to cause the failure of the life support device or system, or to affect its safety or effectiveness.



LittleDiode supplies new, hard to find or obsolete electronic components and semiconductors all over the world.

With over two million different components listed you are sure to find the part you need.

Feel free to visit us today at our online store:

LittleDiode.com

Looking forward to providing you with the best possible service.