

## 24-Bit, 192 kHz Stereo DAC with Volume Control

### Features

- Complete Stereo DAC System: Interpolation, D/A, Output Analog Filtering
- 108 dB Dynamic Range
- 94 dB THD+N
- Direct Stream Digital Mode
- Low Clock Jitter Sensitivity
- +5 V to +3 V Power Supply
- ATAPI Mixing
- On-Chip Digital De-emphasis for 32, 44.1, and 48 kHz
- Volume Control with Soft Ramp
  - 119 dB Attenuation
  - 1 dB Step Size
  - Zero Crossing Click-Free Transitions
- 36 mW with 3 V supply
- Direct Interface with 5 V to 1.8 V Logic

### Description

The CS4391 is a complete stereo digital-to-analog system including digital interpolation, fourth-order delta-sigma digital-to-analog conversion, digital de-emphasis, volume control, channel mixing and analog filtering. The advantages of this architecture include: ideal differential linearity, no distortion mechanisms due to resistor matching errors, no linearity drift over time and temperature and a high tolerance to clock jitter.

The CS4391 accepts PCM data at sample rates from 2 kHz to 192 kHz, DSD audio data, consumes very little power and operates over a wide power supply range. These features are ideal for DVD, A/V receivers, CD and set-top box systems.

### ORDERING INFORMATION

CS4391-KZ	20-pin TSSOP	-10 to 70 °C
CS4391-KZZ	20-pin TSSOP, Lead Free	-10 to 70°C
CDB4391	Evaluation Board	

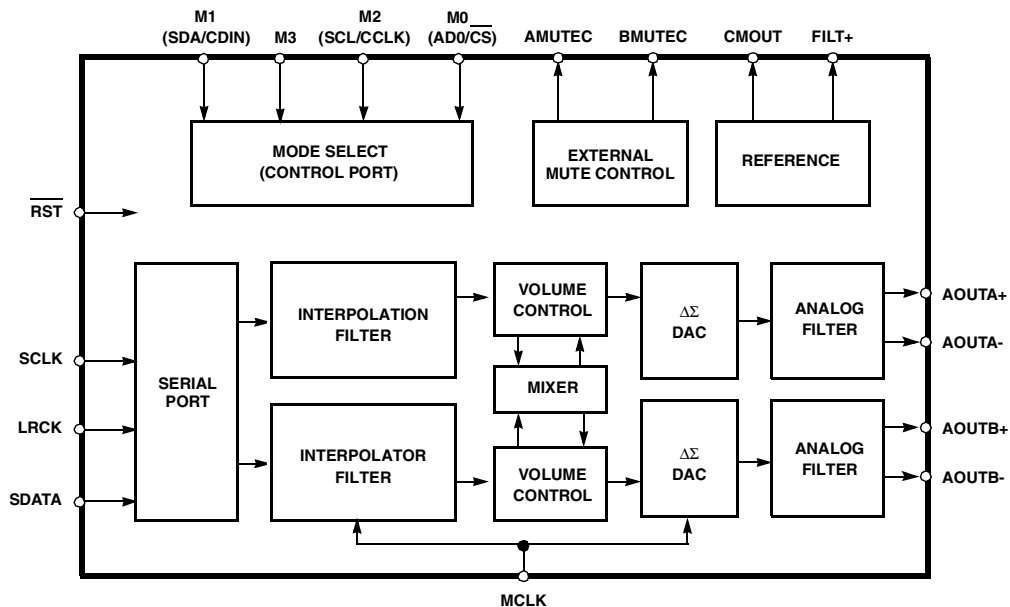

*Preliminary Product Information*

This document contains information for a new product. Cirrus Logic reserves the right to modify this product without notice.

**TABLE OF CONTENTS**

<b>1. CHARACTERISTICS/SPECIFICATIONS .....</b>	<b>5</b>
ANALOG CHARACTERISTICS.....	5
DIGITAL CHARACTERISTICS.....	7
ABSOLUTE MAXIMUM RATINGS.....	7
RECOMMENDED OPERATING CONDITIONS.....	7
SWITCHING CHARACTERISTICS - PCM MODES.....	8
SWITCHING CHARACTERISTICS - DSD .....	9
SWITCHING CHARACTERISTICS - I <sup>2</sup> C CONTROL PORT .....	10
SWITCHING CHARACTERISTICS - SPI CONTROL PORT .....	11
<b>2. TYPICAL CONNECTION DIAGRAMS .....</b>	<b>12</b>
<b>3. REGISTER QUICK REFERENCE .....</b>	<b>14</b>
3.1 Mode Control 1 (address 01h).....	14
3.2 Volume and Mixing Control (address 02h) .....	15
3.3 Channel A Volume Control (address 03h).....	15
3.4 Channel B Volume Control (address 04h).....	15
3.5 Mode Control 2 (address 05h).....	16
<b>4. REGISTER DESCRIPTION .....</b>	<b>17</b>
4.1 Mode Control 1 - Address 01h.....	17
4.1.1 Auto-Mute (Bit 7) .....	17
4.1.2 Digital Interface Formats (Bits 6:4) .....	17
4.1.3 De-Emphasis Control (Bits 3:2) .....	17
4.1.4 Functional Mode (Bits 1:0) .....	17
4.2 Volume and Mixing Control (Address 02h).....	18
4.2.1 Channel A Volume = Channel B Volume (Bit 7) .....	18
4.2.2 Soft Ramp or Zero Cross Enable (Bits 6:5) .....	18
4.2.3 ATAPI Channel Mixing and Muting (Bits 4:0) .....	18
4.3 Channel A Volume Control - Address 03h.....	18
4.4 Channel B Volume Control - Address 04h.....	19
4.4.1 Mute (Bit 7) .....	19
4.4.2 Volume Control (Bits 6:0) .....	19
4.5 Mode Control 2 - Address 05h.....	19
4.5.1 Invert Signal Polarity (Bits 7:6) .....	19
4.5.2 Control Port Enable (Bit 5) .....	19
4.5.3 Power Down (Bit 4) .....	19
4.5.4 AMUTEC = BMUTEC (Bit 3) .....	19
4.5.5 Freeze (Bit 2) .....	20
4.5.6 Master Clock Divide (Bit 1) .....	20
<b>5. PIN DESCRIPTION - PCM DATA MODE .....</b>	<b>21</b>
Reset - $\overline{\text{RST}}$ .....	21
Interface Power - VL.....	21

**Contacting Cirrus Logic Support**

For a complete listing of Direct Sales, Distributor, and Sales Representative contacts, visit the Cirrus Logic web site at: <http://www.cirrus.com>

I<sup>2</sup>C is a registered trademark of Philips Semiconductors.

Preliminary product information describes products which are in production, but for which full characterization data is not yet available. Advance product information describes products which are in development and subject to development changes. Cirrus Logic, Inc. has made best efforts to ensure that the information contained in this document is accurate and reliable. However, the information is subject to change without notice and is provided "AS IS" without warranty of any kind (express or implied). No responsibility is assumed by Cirrus Logic, Inc. for the use of this information, nor for infringements of patents or other rights of third parties. This document is the property of Cirrus Logic, Inc. and implies no license under patents, copyrights, trademarks, or trade secrets. No part of this publication may be copied, reproduced, stored in a retrieval system, or transmitted, in any form or by any means (electronic, mechanical, photographic, or otherwise) without the prior written consent of Cirrus Logic, Inc. Items from any Cirrus Logic website or disk may be printed for use by the user. However, no part of the printout or electronic files may be copied, reproduced, stored in a retrieval system, or transmitted, in any form or by any means (electronic, mechanical, photographic, or otherwise) without the prior written consent of Cirrus Logic, Inc. Furthermore, no part of this publication may be used as a basis for manufacture or sale of any items without the prior written consent of Cirrus Logic, Inc. The names of products of Cirrus Logic, Inc. or other vendors and suppliers appearing in this document may be trademarks or service marks of their respective owners which may be registered in some jurisdictions. A list of Cirrus Logic, Inc. trademarks and service marks can be found at <http://www.cirrus.com>.

---

Serial Audio Data - SDATA .....	21
Serial Clock - SCLK .....	22
Left / Right Clock - LRCK .....	22
Master Clock - MCLK .....	22
Mode Select - M3, M2, M1 and M0 (Stand-alone Mode) .....	22
Mode Select - M3 (Control Port Mode) .....	22
Serial Control Interface Clock - SCL/CCLK (Control Port Mode) .....	23
Serial Control Data I/O - SDA/CDIN (Control Port Mode) .....	23
Address Bit / Chip Select - AD0 / $\overline{\text{CS}}$ (Control Port Mode) .....	23
Positive Voltage Reference - FILT+ .....	23
Common Mode Voltage - CMOUT .....	23
Channel A and Channel B Mute Control - AMUTE <sub>C</sub> and BMUTE <sub>C</sub> .....	23
Differential Analog Output - AOUTB+, AOUTB- and AOUTA+, AOUTA- .....	24
Analog Ground - AGND .....	24
Analog Power - VA .....	24
<b>6. PIN DESCRIPTION - DSD MODE .....</b>	<b>25</b>
DSD Audio Data - DSD_A and DSD_B .....	25
DSD Mode - DSD_Mode .....	25
Master Clock - MCLK .....	25
DSD Serial Clock - DSD_SCLK .....	25
<b>7. APPLICATIONS .....</b>	<b>32</b>
7.1 Recommended Power-up Sequence for Hardware Mode .....	32
7.2 Recommended Power-up Sequence and Access to Control Port Mode .....	32
7.3 Analog Output and Filtering .....	32
<b>8. CONTROL PORT INTERFACE .....</b>	<b>33</b>
8.1 SPI Mode .....	33
8.2 I2C Mode .....	33
<b>9. PARAMETER DEFINITIONS .....</b>	<b>37</b>
Total Harmonic Distortion + Noise (THD+N) .....	37
Dynamic Range .....	37
Interchannel Isolation .....	37
Interchannel Gain Mismatch .....	37
Gain Error .....	37
Gain Drift .....	37
<b>10. REFERENCES .....</b>	<b>37</b>
<b>11. PACKAGE DIMENSIONS .....</b>	<b>38</b>

**LIST OF TABLES**

Figure:1. Digital Interface Formats - PCM Modes .....	26
Figure:2. Digital Interface Formats - DSD Mode .....	26
Figure:3. De-Emphasis Mode Selection .....	26
Figure:4. Functional Mode Selection .....	26
Figure:5. Soft Cross or Zero Cross Mode Selection .....	26
Figure:6. ATAPI Decode .....	27
Figure:7. Digital Volume Control .....	27
Figure:8. Single Speed (4 to 50 kHz sample rates) Common Clock Frequencies .....	28
Figure:9. Double Speed (50 to 100 kHz sample rates) Common Clock Frequencies .....	28
Figure:10. Quad Speed (100 to 200 kHz sample rates) Common Clock Frequencies .....	28
Figure:11. Single Speed (4 to 50 kHz) Digital Interface Format, Stand-Alone Mode Options .....	28
Figure:12. Single Speed Only (4 to 50 kHz) De-Emphasis, Stand-Alone Mode Options .....	28
Figure:13. Double Speed (50 to 100 kHz) Digital Interface Format, Stand-Alone Mode Options .....	28
Figure:14. Quad Speed (100 to 200 kHz) Digital Interface Format, Stand-Alone Mode Options .....	29
Figure:15. Direct Stream Digital (DSD), Stand-Alone Mode Options .....	29
Figure:16. Memory Address Pointer (MAP) .....	34

**LIST OF FIGURES**

Figure 1. Serial Mode Input Timing .....	8
Figure 2. Direct Stream Digital - Serial Audio Input Timing .....	9
Figure 3. I <sup>2</sup> C Control Port Timing .....	10
Figure 4. SPI Control Port Timing .....	11
Figure 5. Typical Connection Diagram - PCM Mode .....	12
Figure 6. Typical Connection Diagram - DSD Mode .....	13
Figure 7. Format 0, Left Justified up to 24-Bit Data .....	30
Figure 8. Format 1, I2S up to 24-Bit Data .....	30
Figure 9. Format 2, Right Justified 16-Bit Data .....	30
Figure 10. Format 3, Right Justified 24-Bit Data .....	30
Figure 11. Format 4, Right Justified 20-Bit Data. (Available in Control Port Mode only) .....	31
Figure 12. Format 5, Right Justified 18-Bit Data. (Available in Control Port Mode only) .....	31
Figure 13. De-Emphasis Curve .....	31
Figure 14. ATAPI Block Diagram .....	31
Figure 15. CS4391 Output Filter .....	32
Figure 16. Control Port Timing, SPI mode .....	34
Figure 17. Control Port Timing, I <sup>2</sup> C Mode .....	34
Figure 18. Single-Speed Frequency Response .....	35
Figure 19. Single-Speed Transition Band .....	35
Figure 20. Single-Speed Transition Band .....	35
Figure 21. Single-Speed Stopband Rejection .....	35
Figure 22. Double-Speed Frequency Response .....	35
Figure 23. Double-Speed Transition Band .....	35
Figure 24. Double-Speed Transition Band .....	36
Figure 25. Double-Speed Stopband Rejection .....	36

## 1. CHARACTERISTICS/SPECIFICATIONS

**ANALOG CHARACTERISTICS** ( $T_A = 25^\circ\text{C}$ ; Logic "1" = VL = VA; Logic "0" = AGND; Full-Scale Output Sine Wave, 997 Hz; MCLK = 12.288 MHz; SCLK = 3.072 MHz, Sample Rate = 48, 96 or 192 kHz, 24-bit data, Measurement Bandwidth 10 Hz to 20 kHz, unless otherwise specified. Test load  $R_L = 5\text{ k}\Omega$ ,  $C_L = 10\text{ pF}$ )

Parameter	Symbol	VA = 3 V			VA = 5 V			Unit	
		Min	Typ	Max	Min	Typ	Max		
<b>Dynamic Performance</b>									
Dynamic Range	(Note 17)								
	unweighted	97	102	-	100	105	-	dB	
	A-Weighted	100	105	-	103	108	-	dB	
40 kHz Bandwidth	A-Weighted	-	99	-	-	102	-	dB	
Total Harmonic Distortion + Noise	(Note 17,2)	THD+N							
	0 dB	-	-94	-89	-	-94	-89	dB	
	-20 dB	-	-82	-	-	-85	-	dB	
	-60 dB	-	-42	-37	-	-45	-40	dB	
Idle Channel Noise / Signal-to-Noise Ratio		-	105	-	-	108	-	dB	
Interchannel Isolation	(1 kHz)	-	100	-	-	100	-	dB	
<b>Power Supplies</b>									
Power Supply Current	normal operation	$I_A + I_L$	-	12	TBD	-	17	TBD	mA
	power-down state	$I_A + I_L$	-	30	-	-	60	-	$\mu\text{A}$
Power Dissipation	normal operation		-	36	TBD	-	85	TBD	mW
	power-down		-	0.09	-	-	0.3	-	mW
Power Supply Rejection Ratio (1 kHz) (Note 3)		PSRR	-	60	-	-	60	-	dB
	(60 Hz)		-	40	-	-	40	-	dB

Parameter	Symbol	Min	Typ	Max	Units
<b>Analog Output</b>					
Full Scale Differential Output Voltage		TBD	1.1VA	TBD	Vpp
Common Mode Voltage	CMOUT	-	0.5VA	-	VDC
Interchannel Gain Mismatch		-	0.1	-	dB
Gain Drift		-	100	-	ppm/ $^\circ\text{C}$
AC-Load Resistance	$R_L$	5	-	-	k $\Omega$
Load Capacitance	$C_L$	-	-	100	pF

**ANALOG CHARACTERISTICS** (continued)

Parameter	Symbol	Min	Typ	Max	Unit
<b>Combined Digital and On-chip Analog Filter Response - Single Speed Mode</b>					
Passband (Note 3)		0	-	.4535	Fs
to -0.05 dB corner		0	-	.4998	Fs
to -3 dB corner					
Frequency Response 10 Hz to 20 kHz		-.02	-	+.035	dB
StopBand		.5465	-	-	Fs
StopBand Attenuation (Note 5)		50	-	-	dB
Group Delay	tgd	-	9/Fs	-	s
Passband Group Delay Deviation 0 - 20 kHz		-	±0.36/Fs	-	s
De-emphasis Error (Relative to 1 kHz)					
Control Port Mode					
Fs = 32 kHz		-	-	+.2/- .1	dB
Fs = 44.1 kHz		-	-	+.05/- .14	dB
Fs = 48 kHz		-	-	+0/.22	dB
Stand-Alone Mode					
Fs = 32 kHz		-	-	TBD	dB
Fs = 44.1 kHz		-	-	+.05/- .14	dB
Fs = 48 kHz		-	-	TBD	dB
<b>Combined Digital and On-chip Analog Filter Response - Double Speed Mode</b>					
Passband (Note 4)		0	-	.4621	Fs
to -0.1 dB corner		0	-	.4982	Fs
to -3 dB corner					
Frequency Response 10 Hz to 20 kHz		-0.1	-	0	dB
StopBand		.577	-	-	Fs
StopBand Attenuation (Note 5)		55	-	-	dB
Group Delay	tgd	-	9/Fs	-	s
Passband Group Delay Deviation 0 - 20 kHz		-	±0.23/Fs	-	s
<b>On-chip Analog Filter Response - Quad Speed Mode</b>					
Passband (Note 4)		0	-	0.25	Fs
to -3 dB corner					
Frequency Response 10 Hz to 20 kHz		-0.7	-	0	dB
<b>On-chip Analog Filter Response - DSD Mode</b>					
Passband (Note 4)		0	-	1.0	Fs
to -3 dB corner					
Frequency Response 10 Hz to 20 kHz		-0.7	-	0	dB

Notes: 17. Triangular PDF dithered data.

18. THD+N specifications for 48 kHz sample rates are made over a 20 kHz Bandwidth.
19. Valid with the recommended capacitor values on FILT+ and CMOUT as shown in Figure 1. Increasing the capacitance will also increase the PSRR.
20. Response is clock dependent and will scale with Fs. Note that the response plots (Figures 18-25) have been normalized to Fs and can be de-normalized by multiplying the X-axis scale by Fs.
21. For Single-Speed Mode, the Measurement Bandwidth is 0.5465 Fs to 3 Fs.  
For Double-Speed Mode, the Measurement Bandwidth is 0.577 Fs to 1.4 Fs.

**DIGITAL CHARACTERISTICS** ( $T_A = 25^\circ\text{C}$ )

Parameters	Symbol	Min	Typ	Max	Units
High-Level Input Voltage	$V_{IH}$	70%	-	-	VL
Low-Level Input Voltage	$V_{IL}$		-	20%	VL
Input Leakage Current	$I_{in}$	-	-	$\pm 10$	$\mu\text{A}$
Input Capacitance		-	8	-	pF
Maximum MUTEK Drive Current		-	3	-	mA

**ABSOLUTE MAXIMUM RATINGS** (AGND = 0 V; all voltages with respect to ground.)

Parameters	Symbol	Min	Max	Units
DC Power Supply	VA	-0.3	6.0	V
	VL	-0.3	VA	V
Input Current, Any Pin Except Supplies	$I_{in}$	-	$\pm 10$	mA
Digital Input Voltage	$V_{IND}$	-0.3	VL+0.4	V
Ambient Operating Temperature (power applied)	$T_A$	-55	125	$^\circ\text{C}$
Storage Temperature	$T_{stg}$	-65	150	$^\circ\text{C}$

WARNING: Operation at or beyond these limits may result in permanent damage to the device. Normal operation is not guaranteed at these extremes.

**RECOMMENDED OPERATING CONDITIONS** (AGND = 0V; all voltages with respect to ground.)

Parameters	Symbol	Min	Typ	Max	Units
DC Power Supply	VA	2.7	5.0	5.5	V
	VL	1.8	-	VA	V

**SWITCHING CHARACTERISTICS - PCM MODES** ( $T_A = -10$  to  $70^\circ\text{C}$ ;  $V_L = 5.5$  to  $1.8$  Volts;  
 Inputs: Logic 0 = 0 V, Logic 1 =  $V_L$ ,  $C_L = 20$  pF)

Parameters	Symbol	Min	Typ	Max	Units
Input Sample Rate	$F_s$	4	-	200	kHz
LRCK Duty Cycle		45	50	55	%
MCLK Duty Cycle		40	50	60	%
SCLK Frequency		-	-	MCLK/2	Hz
SCLK Frequency	Note 22	-	-	MCLK/4	Hz
SCLK rising to LRCK edge delay	$t_{slrd}$	20	-	-	ns
SCLK rising to LRCK edge setup time	$t_{slrs}$	20	-	-	ns
SDATA valid to SCLK rising setup time	$t_{sdrls}$	20	-	-	ns
SCLK rising to SDATA hold time	$t_{sdh}$	20	-	-	ns

Notes: 22. This serial clock is available only in Control Port Mode when the MCLK Divide bit is enabled.

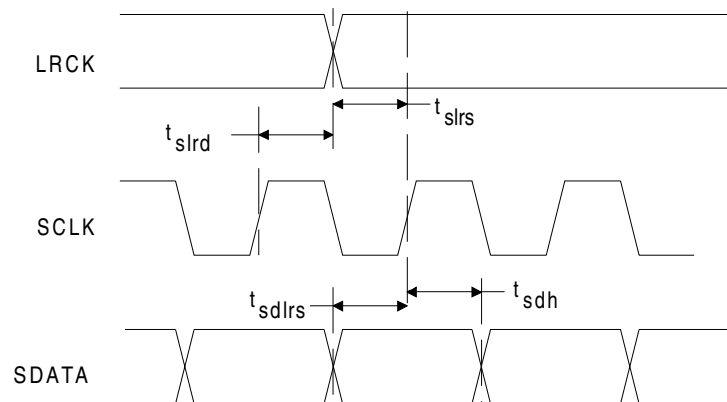

**Figure 1. Serial Mode Input Timing**

**SWITCHING CHARACTERISTICS - DSD** ( $T_A = -10$  to  $70^\circ\text{C}$ ; Logic 0 = AGND = DGND;  
Logic 1 = VL = 5.5 to 1.8 Volts;  $C_L = 20\text{ pF}$ )

Parameter	Symbol	Min	Typ	Max	Unit
MCLK Duty Cycle		40	50	60	%
SCLK Pulse Width Low	$t_{\text{sckl}}$	TBD	-	-	ns
SCLK Pulse Width High	$t_{\text{sckh}}$	TBD	-	-	ns
SCLK Period	$t_{\text{sckw}}$	TBD	-	-	ns
SDIN valid to SCLK rising setup time	$t_{\text{sdhrs}}$	TBD	-	-	ns
SCLK rising to SDIN hold time	$t_{\text{sdh}}$	TBD	-	-	ns

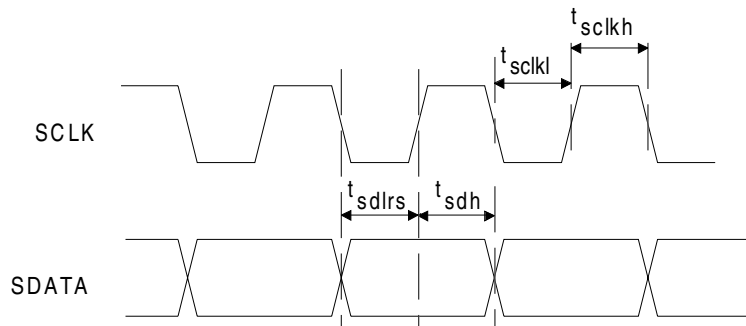

**Figure 2. Direct Stream Digital - Serial Audio Input Timing**

## SWITCHING CHARACTERISTICS - I<sup>2</sup>C CONTROL PORT

(T<sub>A</sub> = 25° C; V<sub>L</sub> = 5.5 to 1.8 Volts; Inputs: logic 0 = AGND, logic 1 = V<sub>L</sub>, C<sub>L</sub> = 30 pF)

Parameter	Symbol	Min	Max	Unit
<b>I<sup>2</sup>C<sup>®</sup> Mode</b>				
SCL Clock Frequency	f <sub>scl</sub>	-	100	KHz
RST Rising Edge to Start	t <sub>irs</sub>	500	-	ns
Bus Free Time Between Transmissions	t <sub>buf</sub>	4.7	-	μs
Start Condition Hold Time (prior to first clock pulse)	t <sub>hdst</sub>	4.0	-	μs
Clock Low time	t <sub>low</sub>	4.7	-	μs
Clock High Time	t <sub>high</sub>	4.0	-	μs
Setup Time for Repeated Start Condition	t <sub>sust</sub>	4.7	-	μs
SDA Hold Time from SCL Falling (Note 23)	t <sub>hdd</sub>	0	-	μs
SDA Setup time to SCL Rising	t <sub>sud</sub>	250	-	ns
Rise Time of Both SDA and SCL Lines	t <sub>r</sub>	-	1	μs
Fall Time of Both SDA and SCL Lines	t <sub>f</sub>	-	300	ns
Setup Time for Stop Condition	t <sub>susp</sub>	4.7	-	μs

Notes: 23. Data must be held for sufficient time to bridge the 300 ns transition time of SCL.

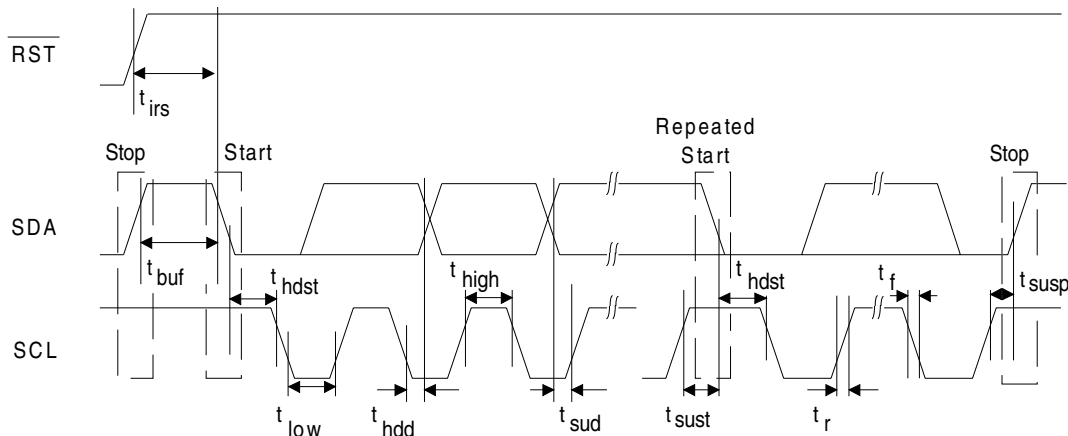

**Figure 3. I<sup>2</sup>C Control Port Timing**

## SWITCHING CHARACTERISTICS - SPI CONTROL PORT

( $T_A = 25^\circ\text{C}$ ;  $V_L = 5.5$  to  $1.8$  Volts; Inputs: logic 0 = AGND, logic 1 =  $V_L$ ,  $C_L = 30$  pF)

Parameter	Symbol	Min	Max	Unit
<b>SPI Mode</b>				
CCLK Clock Frequency	$f_{\text{sclk}}$	-	6	MHz
RST Rising Edge to CS Falling	$t_{\text{srs}}$	500	-	ns
CCLK Edge to $\overline{\text{CS}}$ Falling (Note 24)	$t_{\text{spi}}$	500	-	ns
CS High Time Between Transmissions	$t_{\text{csh}}$	1.0	-	$\mu\text{s}$
CS Falling to CCLK Edge	$t_{\text{css}}$	20	-	ns
CCLK Low Time	$t_{\text{scl}}$	66	-	ns
CCLK High Time	$t_{\text{sch}}$	66	-	ns
CDIN to CCLK Rising Setup Time	$t_{\text{dsu}}$	40	-	ns
CCLK Rising to DATA Hold Time (Note 25)	$t_{\text{dh}}$	15	-	ns
Rise Time of CCLK and CDIN (Note 26)	$t_{r2}$	-	100	ns
Fall Time of CCLK and CDIN (Note 26)	$t_{f2}$	-	100	ns

Notes: 24.  $t_{\text{spi}}$  only needed before first falling edge of  $\overline{\text{CS}}$  after  $\overline{\text{RST}}$  rising edge.  $t_{\text{spi}} = 0$  at all other times.

25. Data must be held for sufficient time to bridge the transition time of CCLK.

26. For  $F_{\text{SCK}} < 1$  MHz

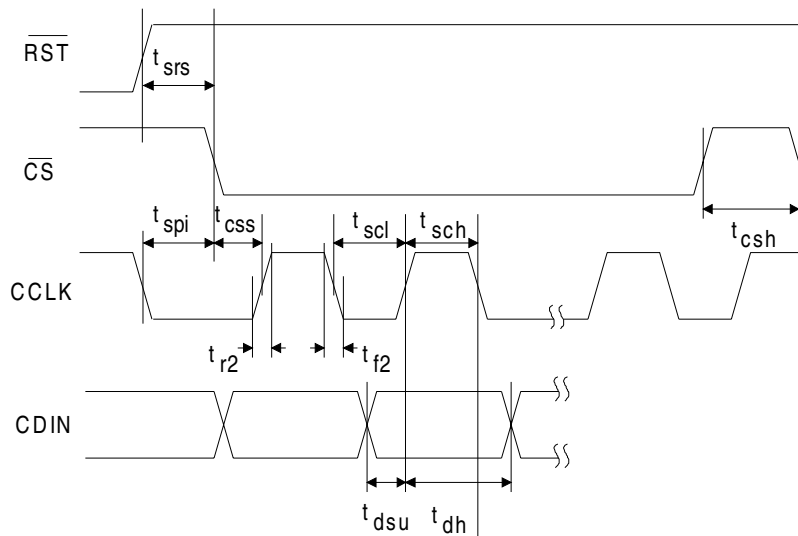

**Figure 4. SPI Control Port Timing**

**2. TYPICAL CONNECTION DIAGRAMS**

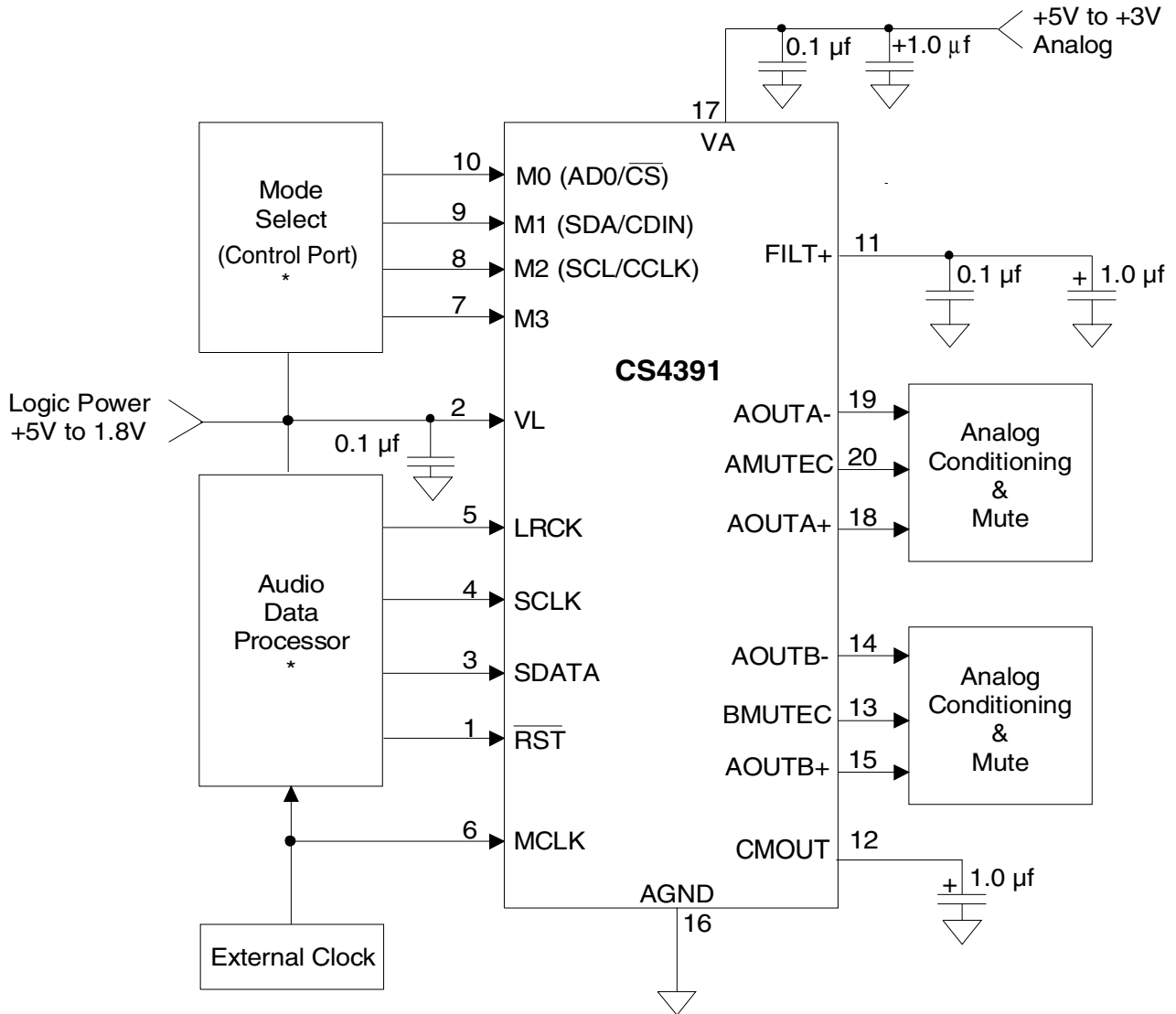

**Figure 5. Typical Connection Diagram - PCM Mode**

\* A high logic level for all digital inputs should not exceed VL.

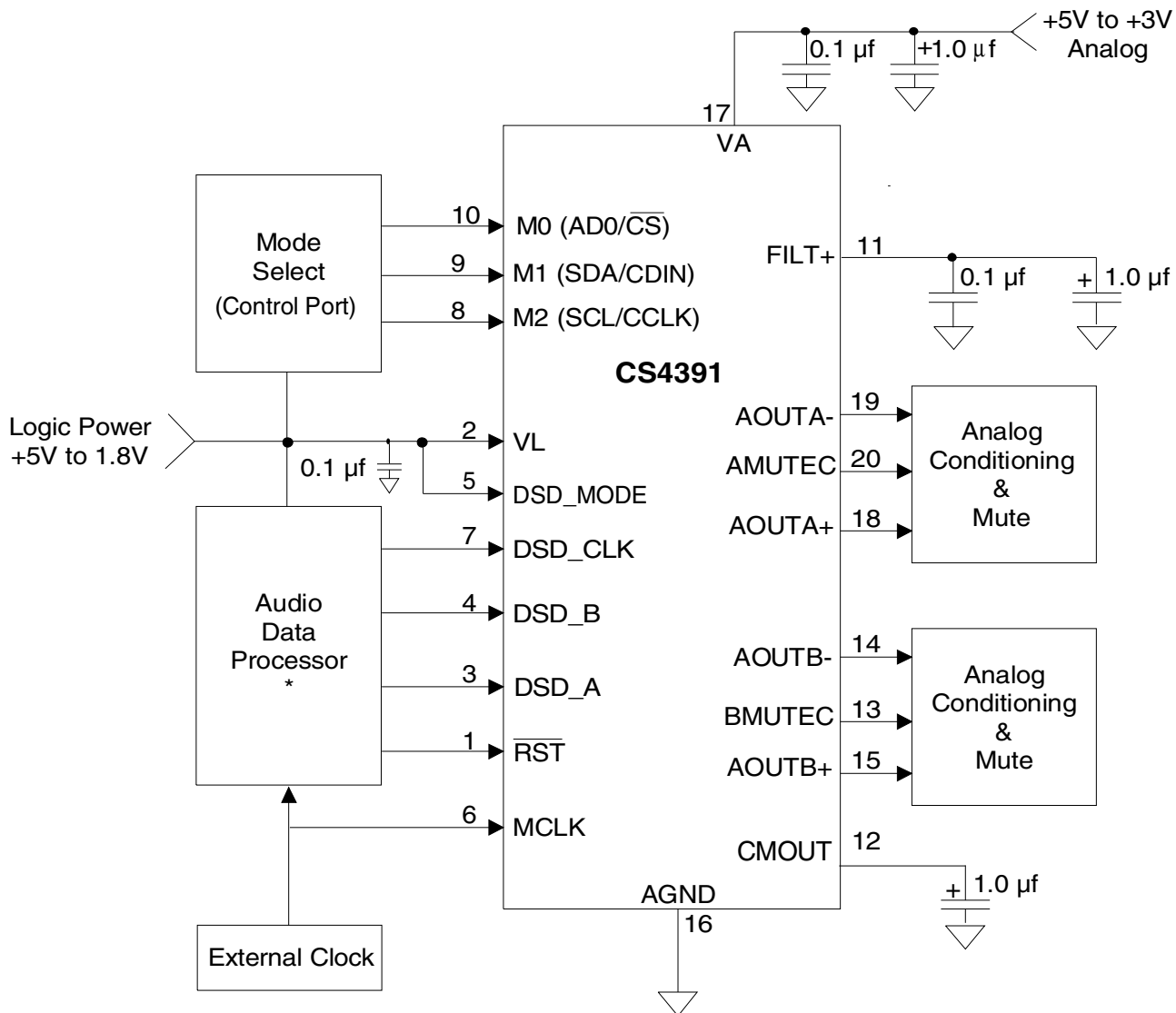

**Figure 6. Typical Connection Diagram - DSD Mode**  
 \* A high logic level for all digital inputs should not exceed VL.

### 3. REGISTER QUICK REFERENCE

\*\* "default" ==> bit status after power-up-sequence or reset\*\*

#### 3.1 MODE CONTROL 1 (ADDRESS 01H)

7	6	5	4	3	2	1	0
AMUTE	DIF2	DIF1	DIF0	DEM1	DEM0	FM1	FM0
1	0	0	0	0	0	0	0

*AMUTE (Auto-mute)*

Default = '1'.

0 - Disabled

1 - Enabled

*DIF2, DIF1 and DIF0 (Digital Interface Format - PCM Modes). See Table 1*

Default = '0'.

000 - Format 0, Left Justified, up to 24-bit data

001 - Format 1, I<sup>2</sup>S, up to 24-bit data

010 - Format 2, Right Justified, 16-bit Data

011 - Format 3, Right Justified, 24-bit Data

100 - Format 4, Right Justified, 20-bit Data

101 - Format 5, Right Justified, 18-bit Data

110 - Reserved

111 - Reserved

*DIF2, DIF1 and DIF0 (Digital Interface Format - DSD Mode Only). See Table 2*

Default = '0'.

000 - Format 0, 64x oversampled DSD data with a 4x MCLK to DSD data rate

001 - Format 1, 64x oversampled DSD data with a 6x MCLK to DSD data rate

010 - Format 2, 64x oversampled DSD data with a 8x MCLK to DSD data rate

011 - Format 3, 64x oversampled DSD data with a 12x MCLK to DSD data rate

100 - Format 4, 128x oversampled DSD data with a 2x MCLK to DSD data rate

101 - Format 5, 128x oversampled DSD data with a 3x MCLK to DSD data rate

110 - Format 6, 128x oversampled DSD data with a 4x MCLK to DSD data rate

111 - Format 7, 128x oversampled DSD data with a 6x MCLK to DSD data rate

*DEM1, DEM0 (De-Emphasis Mode). See Table 3*

Default = '00'.

00 - No De-emphasis

01 - 44.1 kHz De-Emphasis

10 - 48 kHz De-Emphasis

11 - 32 kHz De-Emphasis

*FM1, FM0 (Functional Mode). See Table 4*

Default = '00'.

00 - Single-Speed Mode (4 to 50 kHz sample rates)

01 - Double-Speed Mode (50 to 100 kHz sample rates)

10 - Quad-Speed Mode (100 to 200 kHz sample rates)

11 - Direct Stream Digital Mode

**3.2 VOLUME AND MIXING CONTROL (ADDRESS 02H)**

7	6	5	4	3	2	1	0
A = B	Soft	Zero Cross	ATAPI4	ATAPI3	ATAPI2	ATAPI1	ATAPI0
0	1	0	0	1	0	0	1

*A = B (Channel A Volume = Channel B Volume)*

Default = '0'.

0 - AOUTA volume is determined by register 03h and AOUTB volume is determined by register 04h.

1 - AOUTA and AOUTB volumes are determined by register 03h and register 04h is ignored.

*Soft & Zero Cross (Soft control and zero cross detection control)*

Default = '10'.

SoftZero CrossMode

00 Changes take effect immediately

01 Changes take effect on zero crossings

10 Changes take effect with a soft ramp (default)

11 Changes take effect in 1/8 dB steps on each zero crossing

*ATAPI 0-4 (Channel mixing and muting). See Table 6*

Default = '01001', (Stereo)

AOUTA = Left Channel

AOUTB = Right Channel

**3.3 CHANNEL A VOLUME CONTROL (ADDRESS 03H)**

*See Channel B Volume Control (address 04h)*

**3.4 CHANNEL B VOLUME CONTROL (ADDRESS 04H)**

7	6	5	4	3	2	1	0
MUTE	VOL6	VOL5	VOL4	VOL3	VOL2	VOL1	VOL0
0	0	0	0	0	0	0	0

*MUTE*

Default = '0'

0 - Disabled

1 - Enabled

*Volume*

Default = '0'

(Refer to Table 7)

**3.5 MODE CONTROL 2 (ADDRESS 05H)**

7	6	5	4	3	2	1	0
INVERT_A	INVERT_B	CPEN	PDN	MUTEC A = B	FREEZE	MCLK Divide	Reserved
0	0	1	1	0	0	0	0

*INVERT\_A (Invert Channel A)*

Default = '0'.

0 - Disabled

1 - Enabled

*INVERT\_B (Invert Channel B)*

Default = '0'.

0 - Disabled

1 - Enabled

*CPEN (Control Port Enable)*

Default = '0'

0 - Disabled (Stand-Alone Mode)

1 - Enabled (Control Port Mode)

*PDN (Power-Down)*

Default = '1'.

0 - Disabled

1 - Enabled

*MUTEC A=B*

Default = '0'.

0 - Disabled

1 - Enabled

*FREEZE*

Default = 0.

0 - Disabled

1 - Enabled

*MCLK Divide*

Default = 0.

0 - Disabled

1 - Enabled

## 4. REGISTER DESCRIPTION

\*\* All register access is R/W in I<sup>2</sup>C mode and write only in SPI mode \*\*

### 4.1 MODE CONTROL 1 - ADDRESS 01H

7	6	5	4	3	2	1	0
AMUTE	DIF2	DIF1	DIF0	DEM1	DEM0	FM1	FM0

#### 4.1.1 Auto-Mute (Bit 7)

*Function:*

The Digital-to-Analog converter output will mute following the reception of 8192 consecutive audio samples of static 0 or -1. A single sample of non-static data will release the mute. Detection and muting is done independently for each channel. (However, Auto-Mute detection and muting can become dependent on either channel if the Mute A = B function is enabled.) The common mode on the output will be retained and the Mute Control pin for that channel will go active during the mute period. The muting function is effected, similar to volume control changes, by the Soft and Zero Cross bits in the Volume and Mixing Control register.

#### 4.1.2 Digital Interface Formats (Bits 6:4)

*Function:*

PCM Mode - The required relationship between the Left/Right clock, serial clock and serial data is defined by the Digital Interface Format and the options are detailed in Table 2 and Figures 7-24.

DSD Mode - The relationship between the oversampling ratio of the DSD audio data and the required Master clock to DSD data rate is defined by the Digital interface Format pins. Note that the Functional Mode registers must be set to DSD Mode.

See Table 1 (PCM Modes)

See Table 2 (DSD Mode)

#### 4.1.3 De-Emphasis Control (Bits 3:2)

*Function:*

Implementation of the standard 15  $\mu$ s/50  $\mu$ s digital de-emphasis filter response, Figure 13, requires reconfiguration of the digital filter to maintain the proper filter response for 32, 44.1 or 48 kHz sample rates. NOTE: De-emphasis is available only in Single-Speed Mode.

See Table 3

#### 4.1.4 Functional Mode (Bits 1:0)

*Function:*

Selects the required range of input sample rates or DSD Mode.

See Table 4

**4.2 VOLUME AND MIXING CONTROL (ADDRESS 02H)**

7	6	5	4	3	2	1	0
A = B	Soft	Zero Cross	ATAPI4	ATAPI3	ATAPI2	ATAPI1	ATAPI0

**4.2.1 Channel A Volume = Channel B Volume (Bit 7)**

*Function:*

The AOUTA and AOUTB volume levels are independently controlled by the A and the B Channel Volume Control Bytes when this function is disabled. The volume on both AOUTA and AOUTB are determined by the A Channel Volume Control Byte and the B Channel Byte is ignored when this function is enabled.

**4.2.2 Soft Ramp or Zero Cross Enable (Bits 6:5)**

*Function:*

Soft Ramp Enable

Soft Ramp allows level changes, both muting and attenuation, to be implemented by incrementally ramping, in 1/8 dB steps, from the current level to the new level at a rate of 1dB per 8 left/right clock periods.

Zero Cross Enable

Zero Cross Enable dictates that signal level changes, either by attenuation changes or muting, will occur on a signal zero crossing to minimize audible artifacts. The requested level change will occur after a timeout period between 512 and 1024 sample periods (10.7 ms to 21.3 ms at 48 kHz sample rate) if the signal does not encounter a zero crossing. The zero cross function is independently monitored and implemented for each channel.

Soft Ramp and Zero Cross Enable

Soft Ramp and Zero Cross Enable dictates that signal level changes, either by attenuation changes or muting, will occur in 1/8 dB steps and be implemented on a signal zero crossing. The 1/8 dB level change will occur after a timeout period between 512 and 1024 sample periods (10.7 ms to 21.3 ms at 48 kHz sample rate) if the signal does not encounter a zero crossing. The zero cross function is independently monitored and implemented for each channel.

See Table 5

**4.2.3 ATAPI Channel Mixing and Muting (Bits 4:0)**

*Function:*

The CS4391 implements the channel mixing functions of the ATAPI CD-ROM specification.

See Table 6

**4.3 CHANNEL A VOLUME CONTROL - ADDRESS 03H**

See 4.4 Channel B Volume Control - Address 04h

#### 4.4 CHANNEL B VOLUME CONTROL - ADDRESS 04H

7	6	5	4	3	2	1	0
MUTE	VOL6	VOL5	VOL4	VOL3	VOL2	VOL1	VOL0

##### 4.4.1 Mute (Bit 7)

*Function:*

The Digital-to-Analog converter output will mute when enabled. The common mode voltage on the output will be retained. The muting function is effected, similiar to attenuation changes, by the Soft and Zero Cross bits in the Volume and Mixing Control register. The MUTEC pin for that channel will go active during the mute period if the Mute function is enabled. Both the AMUTEC and BMUTEC will go active if either MUTE register is enabled and the MUTEC A = B bit (register 5) is enabled.

##### 4.4.2 Volume Control (Bits 6:0)

*Function:*

The digital volume control allows the user to attenuate the signal in 1 dB increments from 0 to -119 dB. Volume settings are decoded as shown in Table 7. The volume changes are implemented as dictated by the Soft and Zero Cross bits in the Volume and Mixing Control register. All volume settings less than - 119 dB are equivalent to enabling the Mute bit.

#### 4.5 MODE CONTROL 2 - ADDRESS 05H

7	6	5	4	3	2	1	0
INVERT_A	INVERT_B	CPEN	PDN	MUTEC A = B	FREEZE	MCLK Divide	Reserved

##### 4.5.1 Invert Signal Polarity (Bits 7:6)

*Function:*

When set, this bit inverts the signal polarity.

##### 4.5.2 Control Port Enable (Bit 5)

*Function:*

This bit defaults to 0, allowing the device to power-up in Stand-Alone mode. The Control port mode can be accessed by setting this bit to 1. This will allow the operation of the device to be controlled by the registers and the pin definitions will conform to Control Port Mode. To accomplish a clean power-up, the user should write 11h to register 5 within 10 ms following the release of Reset.

##### 4.5.3 Power Down (Bit 4)

*Function:*

The device will enter a low-power state whenever this function is activated. The power-down bit defaults to 'enabled' on power-up and must be disabled before normal operation will begin. The contents of the control registers are retained when the device is in power-down.

##### 4.5.4 AMUTEC = BMUTEC (Bit 3)

*Function:*

When this function is enabled, the individual controls for AMUTEC and BMUTEC are internally connected through a AND gate prior to the output pins. Therefore, the external AMUTEC and BMUTEC pins will go active only when the requirements for both AMUTEC and BMUTEC are valid.

#### **4.5.5 Freeze (Bit 2)**

*Function:*

This function allows modifications to the registers without the changes being taking effect until Freeze is disabled. To make multiple changes in the Control port registers take effect simultaneously, set the Freeze Bit, make all register changes, then Disable the Freeze bit.

#### **4.5.6 Master Clock Divide (Bit 1)**

*Function:*

This function allows the user to select an internal divide by 2 of the Master Clock. This selection is required to access the higher Master Clock rates as shown in Table 9.

## 5. PIN DESCRIPTION - PCM DATA MODE

Reset	$\overline{\text{RST}}$	1	20	AMUTEC	Channel A Mute Control
Logic Voltage	VL	2	19	AOUTA-	Differential Output
Serial Data	SDATA	3	18	AOUTA+	Differential Output
Serial Clock	SCLK	4	17	VA	Analog Power
Left/Right Clock	LRCK	5	16	AGND	Analog Ground
Master Clock	MCLK	6	15	AOUTB+	Differential Output
See Description	M3	7	14	AOUTB-	Differential Output
See Description (SCL/CCLK)	M2	8	13	BMUTEC	Channel B Mute Control
See Description (SDA/CDIN)	M1	9	12	CMOUT	Common Mode Voltage
See Description (AD0/ $\overline{\text{CS}}$ )	M0	10	11	FILT+	Positive Voltage Reference

### Reset - $\overline{\text{RST}}$

*Pin 1, Input*

*Function:*

**Hardware Mode:** The device enters a low power mode and the internal state machine is reset to the default setting when low. When high, the device becomes operational.

**Control Port Mode:** The device enters a low power mode and all internal registers are reset to the default settings, including the control port, when low. When high, the control port becomes operational and the PDN bit must be cleared before normal operation will occur. The control port can not be accessed when reset is low. The Control Port Enable Bit must also be enabled after a device reset.

$\overline{\text{RST}}$  is required to remain low until the power supplies and clocks are applied and stable.

### Interface Power - VL

*Pin 2, Input*

*Function:*

Digital interface power supply. Typically 1.8 to 5.0 VDC. The voltage on this pin determines the logic level high threshold for the digital inputs. The voltage on VL is the maximum allowable input level for all digital inputs.

### Serial Audio Data - SDATA

*Pin 3, Input*

*Function:*

Two's complement MSB-first serial data is input on this pin. The data is clocked into SDATA via the serial clock and the channel is determined by the Left/Right clock. The required relationship between the Left/Right clock, serial clock and serial data is defined by the Mode Control Byte in Control Port Mode or the Mode Pins in Hardware Mode. The options are detailed in Figures 7-24.

---

**Serial Clock - SCLK**

*Pin 4, Input*

*Function:*

Clocks the individual bits of the serial data into the SDATA pin. The required relationship between the Left/Right clock, serial clock and serial data is defined by the Mode Control Byte in Control Port Mode or the Mode pins in Hardware Mode. The options are detailed in Figures 7-24.

**Left / Right Clock - LRCK**

*Pin 5, Input*

*Function:*

The Left / Right clock determines which channel is currently being input on the serial audio data input, SDATA. The frequency of the Left/Right clock must be at the input sample rate. Audio samples in Left/Right sample pairs will be simultaneously output from the digital-to-analog converter whereas Right/Left pairs will exhibit a one sample period difference. The required relationship between the Left/Right clock, serial clock and serial data is defined by the Mode Control Byte in Control Port Mode or the Mode pins in Stand-alone Mode. The options are detailed in Figures 7-24.

**Master Clock - MCLK**

*Pin 6, Input*

*Function:*

The master clock frequency must be either 256x, 384x, 512x, 768x or 1024x the input sample rate in Single Speed Mode; either 128x, 192x 256x, 384x or 512x the input sample rate in Double Speed Mode; or 64x, 96x 128x, 192x or 256 x the input sample rate in Quad Speed Mode. Tables 8-10 illustrate the standard audio sample rates and the required master clock frequencies.

Note: These clocking ratios are only available in Control Port Mode when the MCLK Divide bit is enabled.

**Mode Select - M3, M2, M1 and M0 (Stand-alone Mode)**

*Pins 7, 8, 9 and 10 Inputs*

*Function:*

The Mode Select Pins, M0-M3, select the operational mode of the device as detailed in Tables 11-15.

**Mode Select - M3 (Control Port Mode)**

*Pin 7, Input*

*Function:*

The Mode Select Pin, M3, is not used in PCM Control Port mode and should be terminated to ground.

**Serial Control Interface Clock - SCL/CCLK (Control Port Mode)**

*Pin 8, Input*

*Function:*

Clocks the serial control data into or from SDA/CDIN.

**Serial Control Data I/O - SDA/CDIN (Control Port Mode)**

*Pin 9, Input/Output*

*Function:*

In I<sup>2</sup>C mode, SDA is a data I/O line. CDIN is the input data line for the control port interface in SPI mode.

**Address Bit / Chip Select - AD0 /  $\overline{CS}$  (Control Port Mode)**

*Pin 10, Input*

*Function:*

In I<sup>2</sup>C mode, AD0 is a chip address bit.  $\overline{CS}$  is used to enable the control port interface in SPI mode. The device will enter the SPI mode at anytime a high to low transition is detected on this pin. Once the device has entered the SPI mode, it will remain until either the part is reset or undergoes a power-down cycle.

**Positive Voltage Reference - FILT+**

*Pin 11, Output*

*Function:*

Positive reference for internal sampling circuits. External capacitors are required from FILT+ to analog ground, as shown in Figure 5 and 6. The recommended values will typically provide 60 dB of PSRR at 1 kHz and 40 dB of PSRR at 60 Hz. FILT+ is not intended to supply external current. FILT+ has a typical source impedance of 250 k $\Omega$  and any current drawn from this pin will alter device performance.

**Common Mode Voltage - CMOOUT**

*Pin 12, Output*

*Function:*

Filter connection for internal common mode reference voltage, typically 50% of V<sub>A</sub>. Capacitors must be connected from CMOOUT to analog ground, as shown in Figure 56. CMOOUT is not intended to supply external current. CMOOUT has a typical source impedance of 250 k $\Omega$  and any current drawn from this pin will alter device performance.

**Channel A and Channel B Mute Control - AMUTEC and BMUTEC**

*Pins 13 and 20, Outputs*

*Function:*

The Mute Control pins go high during power-up initialization, reset, muting, master clock to left/right clock frequency ratio is incorrect or power-down. These pins are intended to be used as a control for an external mute circuit to prevent the clicks and pops that can occur in any single supply system. Use of Mute Control is not mandatory but recommended for designs requiring the absolute minimum in extraneous clicks and pops.

**Differential Analog Output - AOUTB+, AOUTB- and AOUTA+, AOUTA-**

*Pins 14, 15 and 18, 19, Outputs*

*Function:*

The full scale differential analog output level is specified in the Analog Characteristics specifications table.

**Analog Ground - AGND**

*Pin 16, Input*

*Function:*

Analog ground reference.

**Analog Power - VA**

*Pin 17, Input*

*Function:*

Analog power supply. Typically 3 to 5 VDC.

## 6. PIN DESCRIPTION - DSD MODE

Reset	$\overline{\text{RST}}$	1	20	AMUTEC	Refer to PCM Mode
Logic Voltage	VL	2	19	AOUTA-	Refer to PCM Mode
Channel A Data	DSD_A	3	18	AOUTA+	Refer to PCM Mode
Channel B Data	DSD_B	4	17	VA	Refer to PCM Mode
DSD Mode Select	DSD_MODE	5	16	AGND	Refer to PCM Mode
Master Clock	MCLK	6	15	AOUTB+	Refer to PCM Mode
DSD Serial Clock	DSD_SCLK	7	14	AOUTB-	Refer to PCM Mode
Refer to PCM Mode (SCL/CCLK) M2		8	13	BMUTEC	Refer to PCM Mode
Refer to PCM Mode (SDA/CDIN) M1		9	12	CMOUT	Refer to PCM Mode
Refer to PCM Mode (AD0/CS) M0		10	11	FILT+	Refer to PCM Mode

### DSD Audio Data - DSD\_A and DSD\_B

*Pins 3 and 4, Inputs*

*Function:*

Direct Stream Digital audio data is clocked into DSD\_A and DSD\_B via the DSD serial clock.

### DSD Mode - DSD\_Mode

*Pin 5, Input*

*Function:*

This pin must be set to a logic '1' and M0-M2 must be properly set to access the DSD Mode in Hardware Mode. Refer to Table 19.

In Control Port Mode, this pin must be set to a logic '1' and the Control Registers must be properly set to access the DSD Mode. Refer to register descriptions.

### Master Clock - MCLK

*Pin 6, Input*

*Function:*

The master clock frequency must be either 4x, 6x, 8x or 12x the DSD data rate for 64x oversampled DSD data or 2x, 3x, 4x or 6x the DSD data rate for 128x oversampled DSD data.

### DSD Serial Clock - DSD\_SCLK

*Pin 7, Input*

*Function:*

Clocks the individual bits of the DSD audio data into the DSD\_A and DSD\_B pins.

DIF2	DIF1	DIFO	DESCRIPTION
0	0	0	Left Justified, up to 24-bit data
0	0	1	I <sup>2</sup> S, up to 24-bit data
0	1	0	Right Justified, 16-bit Data
0	1	1	Right Justified, 24-bit Data
1	0	0	Right Justified, 20-bit Data
1	0	1	Right Justified, 18-bit Data
1	1	0	Reserved
1	1	1	Reserved

**Table 1. Digital Interface Formats - PCM Modes**

DIF2	DIF1	DIFO	DESCRIPTION
0	0	0	64x oversampled DSD data with a 4x MCLK to DSD data rate
0	0	1	64x oversampled DSD data with a 6x MCLK to DSD data rate
0	1	0	64x oversampled DSD data with a 8x MCLK to DSD data rate
0	1	1	64x oversampled DSD data with a 12x MCLK to DSD data rate
1	0	0	128x oversampled DSD data with a 2x MCLK to DSD data rate
1	0	1	128x oversampled DSD data with a 3x MCLK to DSD data rate
1	1	0	128x oversampled DSD data with a 4x MCLK to DSD data rate
1	1	1	128x oversampled DSD data with a 6x MCLK to DSD data rate

**Table 2. Digital Interface Formats - DSD Mode**

DEM1	DEMO	DESCRIPTION
0	0	Disabled
0	1	44.1 kHz de-emphasis
1	0	48 kHz de-emphasis
1	1	32 kHz de-emphasis

**Table 3. De-Emphasis Mode Selection**

FM1	FM0	MODE
0	0	Single-Speed Mode (4 to 50 kHz sample rates)
0	1	Double-Speed Mode (50 to 100 kHz sample rates)
1	0	Quad-Speed Mode (100 to 200 kHz sample rates)
1	1	Direct Stream Digital Mode

**Table 4. Functional Mode Selection**

SOFT	ZERO	Mode
0	0	Changes to affect immediately
0	1	Zero Cross enabled
1	0	Soft Ramp enabled
1	1	Soft Ramp and Zero Cross enabled

**Table 5. Soft Cross or Zero Cross Mode Selection**

ATAPI4	ATAPI3	ATAPI2	ATAPI1	ATAPI0	AOUTA	AOUTB
0	0	0	0	0	MUTE	MUTE
0	0	0	0	1	MUTE	bR
0	0	0	1	0	MUTE	bL
0	0	0	1	1	MUTE	$b[(L+R)/2]$
0	0	1	0	0	aR	MUTE
0	0	1	0	1	aR	bR
0	0	1	1	0	aR	bL
0	0	1	1	1	aR	$b[(L+R)/2]$
0	1	0	0	0	aL	MUTE
0	1	0	0	1	aL	bR
0	1	0	1	0	aL	bL
0	1	0	1	1	aL	$b[(L+R)/2]$
0	1	1	0	0	$a[(L+R)/2]$	MUTE
0	1	1	0	1	$a[(L+R)/2]$	bR
0	1	1	1	0	$a[(L+R)/2]$	bL
0	1	1	1	1	$a[(L+R)/2]$	$b[(L+R)/2]$
1	0	0	0	0	MUTE	MUTE
1	0	0	0	1	MUTE	bR
1	0	0	1	0	MUTE	bL
1	0	0	1	1	MUTE	$[(bL+aR)/2]$
1	0	1	0	0	aR	MUTE
1	0	1	0	1	aR	bR
1	0	1	1	0	aR	bL
1	0	1	1	1	aR	$[(aL+bR)/2]$
1	1	0	0	0	aL	MUTE
1	1	0	0	1	aL	bR
1	1	0	1	0	aL	bL
1	1	0	1	1	aL	$[(aL+bR)/2]$
1	1	1	0	0	$[(aL+bR)/2]$	MUTE
1	1	1	0	1	$[(aL+bR)/2]$	bR
1	1	1	1	0	$[(bL+aR)/2]$	bL
1	1	1	1	1	$[(aL+bR)/2]$	$[(aL+bR)/2]$

**Table 6. ATAPI Decode**

Binary Code	Decimal Value	Volume Setting
0000000	0	0 dB
0010100	20	-20 dB
0101000	40	-40 dB
0111100	60	-60 dB
1011010	90	-90 dB

**Table 7. Digital Volume Control**

Note: These clocking ratios are only available in Control Port Mode when the MCLK Divide bit is enabled.

Sample Rate (kHz)	MCLK (MHz)				See Note
	256x	384x	512x	768x	1024x
32	8.1920	12.2880	16.3840	24.5760	32.7680
44.1	11.2896	16.9344	22.5792	33.8688	45.1584
48	12.2880	18.4320	24.5760	36.8640	49.1520

**Table 8. Single Speed (4 to 50 kHz sample rates) Common Clock Frequencies**

Sample Rate (kHz)	MCLK (MHz)				See Note
	128x	192x	256x	384x	512x
64	8.1920	12.2880	16.3840	24.5760	32.7680
88.2	11.2896	16.9344	22.5792	33.8688	45.1584
96	12.2880	18.4320	24.5760	36.8640	49.1520

**Table 9. Double Speed (50 to 100 kHz sample rates) Common Clock Frequencies**

Sample Rate (kHz)	MCLK (MHz)				See Note
	64x	96x	128x	192x	256x
176.4	11.2896	16.9344	22.5792	33.8688	45.1584
192	12.2880	18.4320	24.5760	36.8640	49.1520

**Table 10. Quad Speed (100 to 200 kHz sample rates) Common Clock Frequencies**

M3	M1 (DIF1)	M0 (DIF0)	DESCRIPTION	FORMAT	FIGURE
0	0	0	Left Justified, up to 24-bit data	0	7
0	0	1	I <sup>2</sup> S, up to 24-bit data	1	8
0	1	0	Right Justified, 16-bit Data	2	9
0	1	1	Right Justified, 24-bit Data	3	10

**Table 11. Single Speed (4 to 50 kHz) Digital Interface Format, Stand-Alone Mode Options**

M3	M2 (DEM)	DESCRIPTION	FIGURE
0	0	No De-Emphasis	13
0	1	De-Emphasis Enabled	13

**Table 12. Single Speed Only (4 to 50 kHz) De-Emphasis, Stand-Alone Mode Options**

M3	M2	M1	M0	DESCRIPTION	FORMAT	FIGURE
1	0	0	0	Left Justified up to 24-bit data	0	7
1	0	0	1	I <sup>2</sup> S up to 24-bit data	1	8
1	0	1	0	Right Justified 16-bit data	2	9
1	0	1	1	Right Justified 24-bit data	3	10

**Table 13. Double Speed (50 to 100 kHz) Digital Interface Format, Stand-Alone Mode Options**

M3	M2	M1	M0	DESCRIPTION	FORMAT	FIGURE
1	1	0	0	Left Justified up to 24-bit data	0	7
1	1	0	1	I <sup>2</sup> S up to 24-bit data	1	8
1	1	1	0	Right Justified 16-bit data	2	9
1	1	1	1	Right Justified 24-bit data	3	10

**Table 14. Quad Speed (100 to 200 kHz) Digital Interface Format, Stand-Alone Mode Options**

DSD_Mode	M2	M1	M0	DESCRIPTION
1	0	0	0	64x oversampled DSD data with a 4x MCLK to DSD data rate
1	0	0	1	64x oversampled DSD data with a 6x MCLK to DSD data rate
1	0	1	0	64x oversampled DSD data with a 8x MCLK to DSD data rate
1	0	1	1	64x oversampled DSD data with a 12x MCLK to DSD data rate
1	1	0	0	128x oversampled DSD data with a 2x MCLK to DSD data rate
1	1	0	1	128x oversampled DSD data with a 3x MCLK to DSD data rate
1	1	1	0	128x oversampled DSD data with a 4x MCLK to DSD data rate
1	1	1	1	128x oversampled DSD data with a 6x MCLK to DSD data rate

**Table 15. Direct Stream Digital (DSD), Stand-Alone Mode Options**

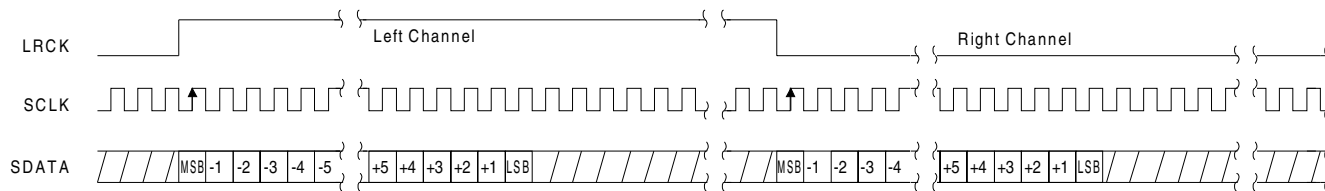

**Figure 7. Format 0, Left Justified up to 24-Bit Data**

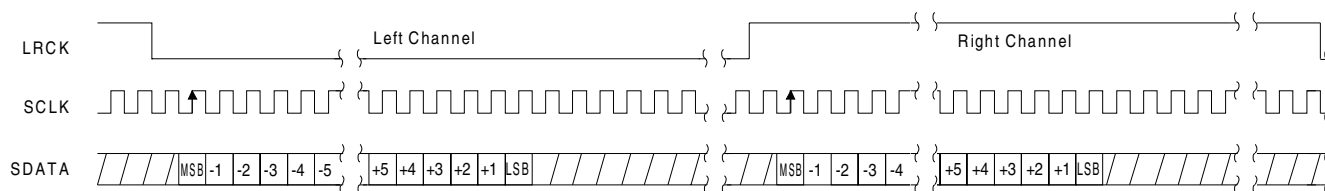

**Figure 8. Format 1, I<sup>2</sup>S up to 24-Bit Data**

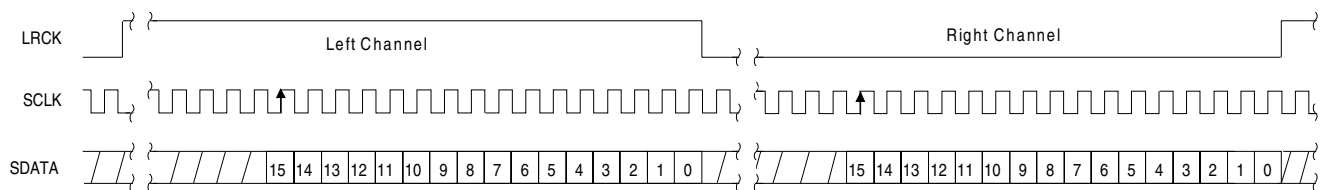

**Figure 9. Format 2, Right Justified 16-Bit Data**

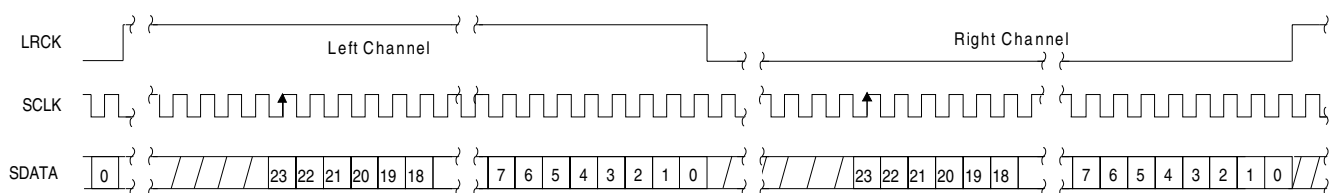

**Figure 10. Format 3, Right Justified 24-Bit Data**

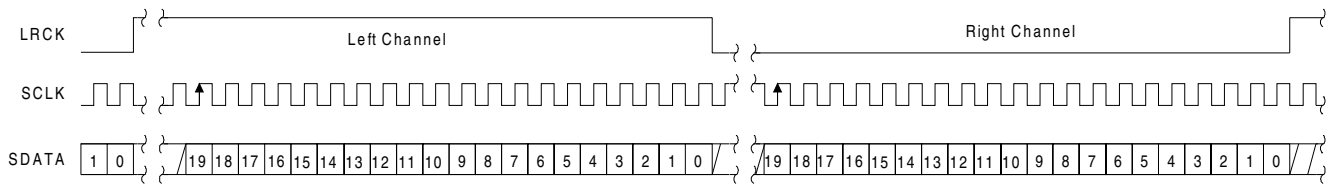

**Figure 11. Format 4, Right Justified 20-Bit Data. (Available in Control Port Mode only)**

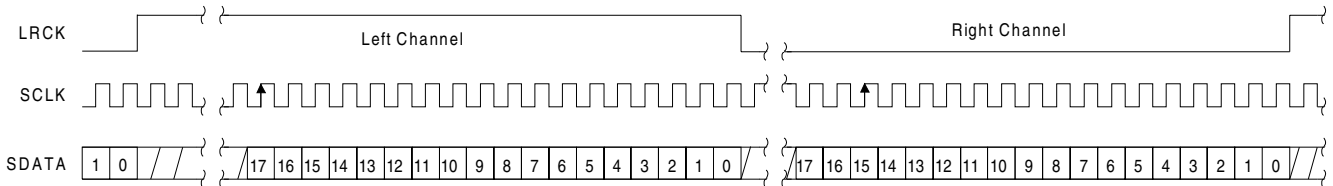

**Figure 12. Format 5, Right Justified 18-Bit Data. (Available in Control Port Mode only)**

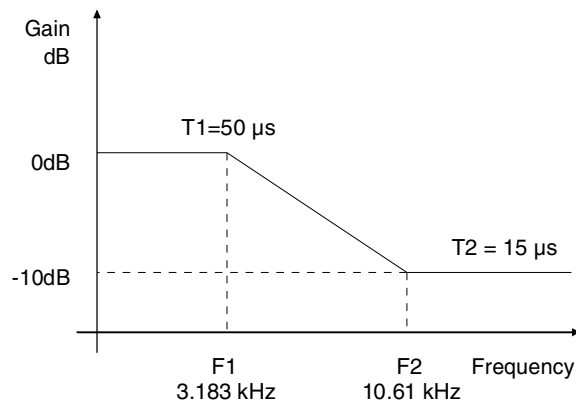

**Figure 13. De-Emphasis Curve**

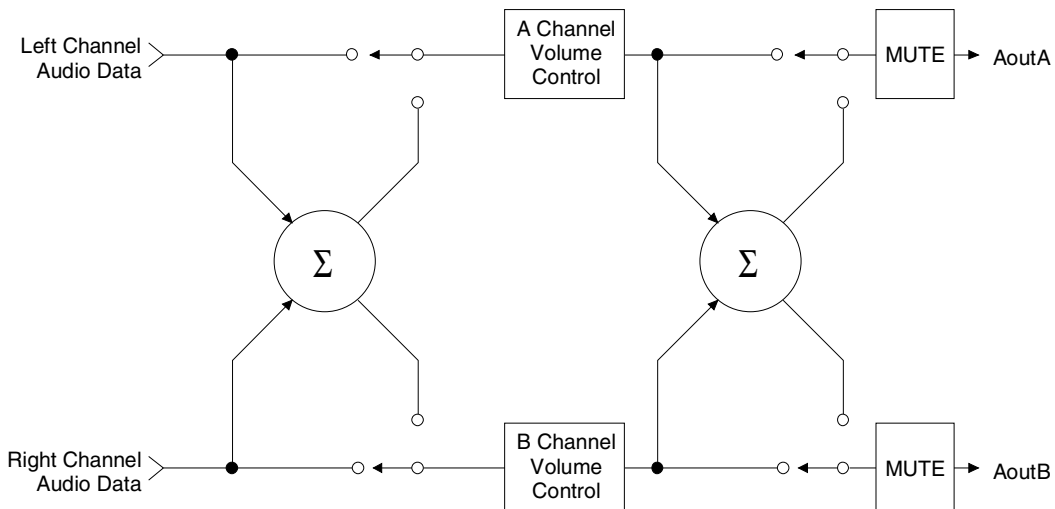

**Figure 14. ATAPI Block Diagram**

## 7. APPLICATIONS

### 7.1 Recommended Power-up Sequence for Hardware Mode

- 1) Hold  $\overline{\text{RST}}$  low until the power supplies, master, and left/right clocks are stable.
- 2) Bring  $\overline{\text{RST}}$  high.

### 7.2 Recommended Power-up Sequence and Access to Control Port Mode

- 1) Hold  $\overline{\text{RST}}$  low until the power supply, master, and left/right clocks are stable. In this state, the control port is reset to its default settings and CMOUT will remain low.
- 2) Bring  $\overline{\text{RST}}$  high. The device will remain in a low power state with CMOUT low and the control port is accessible.
- 3) Write 11h to register 5 within 10 ms cycles following the release of  $\overline{\text{RST}}$ .

- 4) The desired register settings can be loaded while keeping the PDN bit set to 1.
- 5) Set the PDN bit to 0 which will initiate the power-up sequence which requires approximately 10  $\mu\text{s}$ .

### 7.3 Analog Output and Filtering

The application note “Design Notes for a 2-Pole Filter with Differential Input” discusses the second-order Butterworth filter and differential to single-ended converter which was implemented on the CS4391 evaluation board, CDB4391. The CS4391 filter, as seen in Figure 14, is a linear phase design and does not include phase or amplitude compensation for an external filter. Therefore, the DAC system phase and amplitude response will be dependent on the external analog circuitry.

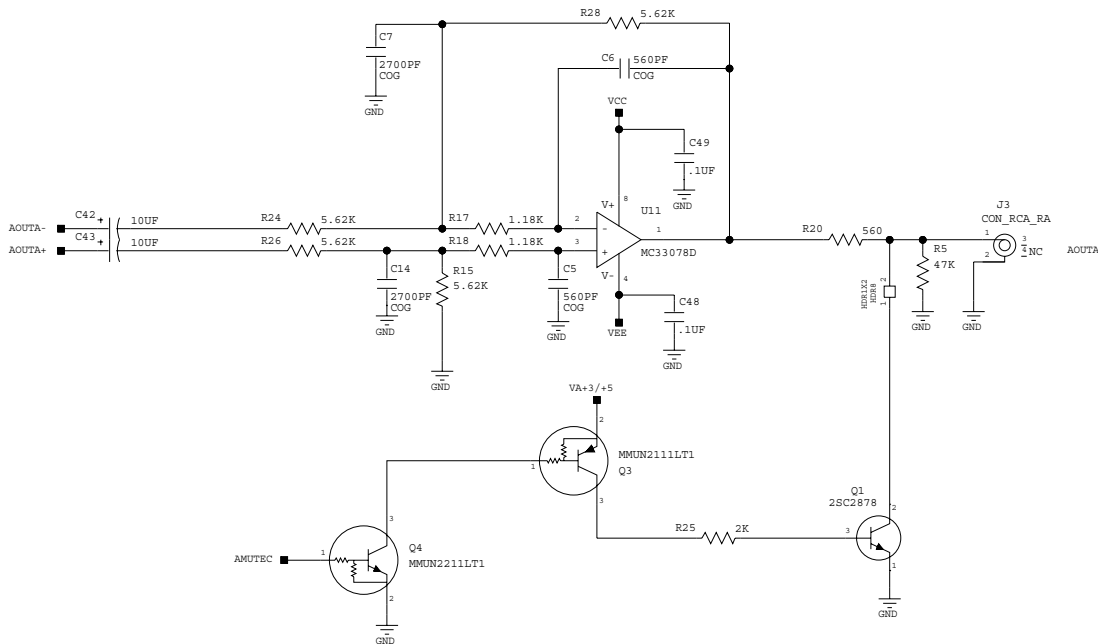

Figure 15. CS4391 Output Filter

## 8. CONTROL PORT INTERFACE

The control port is used to load all the internal settings of the CS4391. The operation of the control port may be completely asynchronous to the audio sample rate. However, to avoid potential interference problems, the control port pins should remain static if no operation is required.

The control port has 2 modes: SPI and I<sup>2</sup>C, with the CS4391 operating as a slave device in both modes. If I<sup>2</sup>C operation is desired, AD0/ $\overline{\text{CS}}$  should be tied to VA or AGND. If the CS4391 ever detects a high to low transition on AD0/ $\overline{\text{CS}}$  after power-up, SPI mode will be selected. The control port registers are write-only in SPI mode.

### 8.1 SPI Mode

In SPI mode,  $\overline{\text{CS}}$  is the CS4391 chip select signal, CCLK is the control port bit clock, CDIN is the input data line from the microcontroller and the chip address is 0010000. All signals are inputs and data is clocked in on the rising edge of CCLK.

Figure 16 shows the operation of the control port in SPI mode. To write to a register, bring  $\overline{\text{CS}}$  low. The first 7 bits on CDIN form the chip address, and must be 0010000. The eighth bit is a read/write indicator ( $\text{R}/\overline{\text{W}}$ ), which must be low to write. The next 8 bits form the Memory Address Pointer (MAP), which is set to the address of the register that is to be updated. The next 8 bits are the data which will be placed into the register designated by the MAP. See Table 16.

The CS4391 has MAP auto increment capability, enabled by the INCR bit in the MAP register. If

INCR is 0, then the MAP will stay constant for successive writes. If INCR is set to 1, then MAP will auto increment after each byte is written, allowing block reads or writes of successive registers.

### 8.2 I<sup>2</sup>C Mode

In I<sup>2</sup>C mode, SDA is a bi-directional data line. Data is clocked into and out of the part by the clock, SCL, with the clock to data relationship as shown in Figure 3. There is no  $\overline{\text{CS}}$  pin. Pin AD0 forms the partial chip address and should be tied to VA or AGND as required. The upper 6 bits of the 7-bit address field must be 001000. To communicate with the CS4391 the LSB of the chip address field, which is the first byte sent to the CS4391, should match the setting of the AD0 pin. The eighth bit of the address byte is the  $\text{R}/\overline{\text{W}}$  bit (high for a read, low for a write). If the operation is a write, the next byte is the Memory Address Pointer, MAP, which selects the register to be read or written. The MAP is then followed by the data to be written. If the operation is a read, then the contents of the register pointed to by the MAP will be output after the chip address.

The CS4391 has MAP auto increment capability, enabled by the INCR bit in the MAP register. If INCR is 0, then the MAP will stay constant for successive writes. If INCR is set to 1, then MAP will auto increment after each byte is written, allowing block reads or writes of successive registers.

For more information on I<sup>2</sup>C, please see “The I<sup>2</sup>C-Bus Specification: Version 2.0”, listed in the References section.

7	6	5	4	3	2	1	0
INCR	Reserved	Reserved	Reserved	Reserved	MAP2	MAP1	MAP0
0	0	0	0	0	0	0	0

INCR (Auto MAP Increment Enable)

Default = '0'.

0 - Disabled

1 - Enabled

MAP0-2 (Memory Address Pointer)

Default = '000'.

**Table 16. Memory Address Pointer (MAP)**

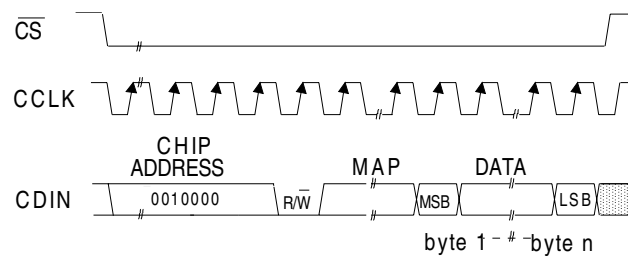

MAP = Memory Address Pointer

**Figure 16. Control Port Timing, SPI mode**

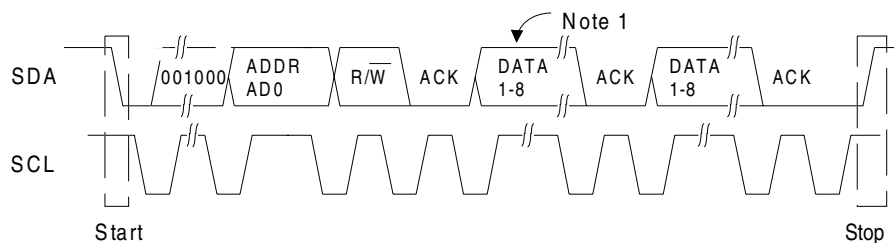

Note: If operation is a write, this byte contains the Memory Address Pointer, MAP.

**Figure 17. Control Port Timing, I<sup>2</sup>C Mode**

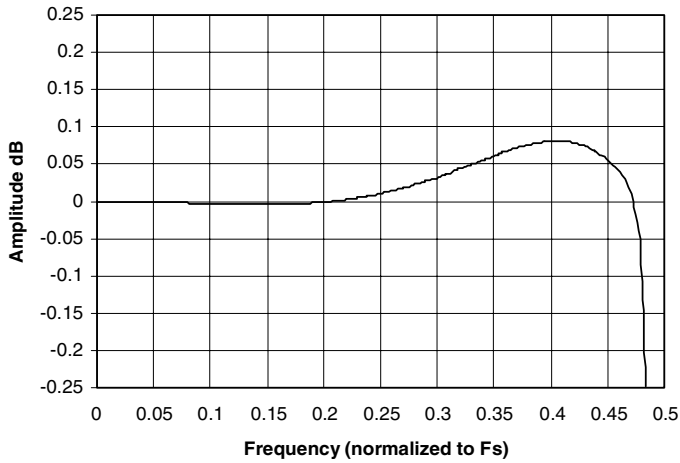

**Figure 18. Single-Speed Frequency Response**

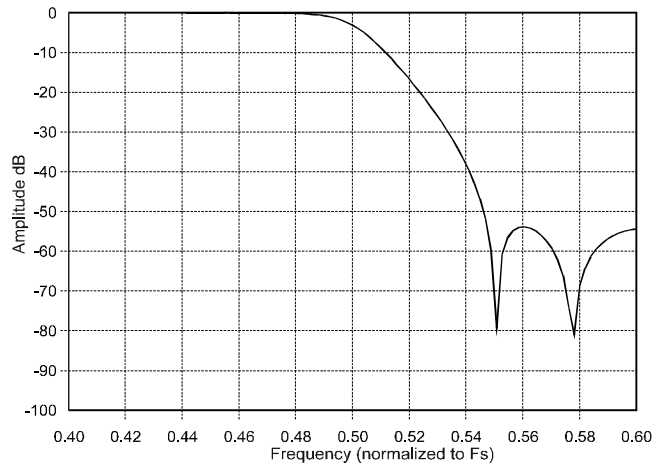

**Figure 19. Single-Speed Transition Band**

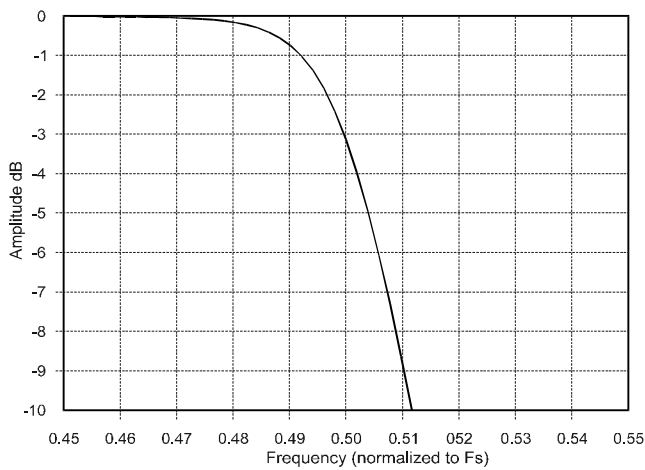

**Figure 20. Single-Speed Transition Band**

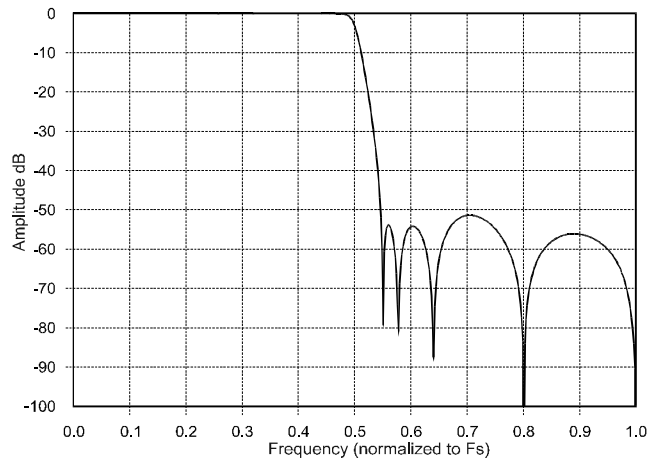

**Figure 21. Single-Speed Stopband Rejection**

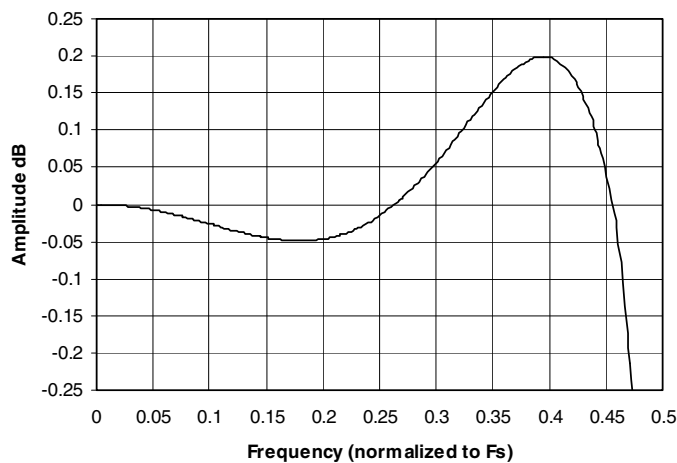

**Figure 22. Double-Speed Frequency Response**

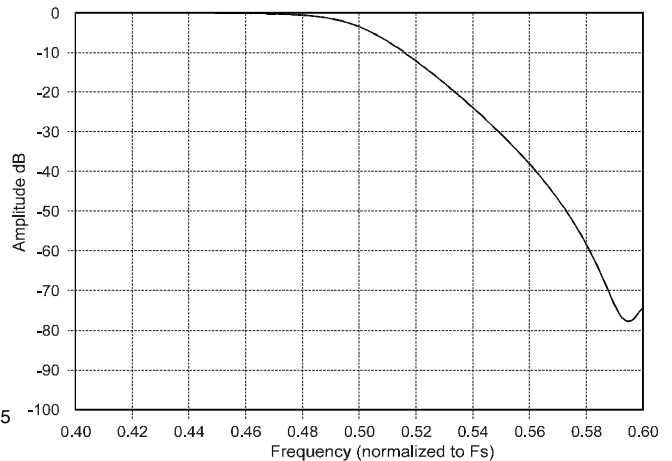

**Figure 23. Double-Speed Transition Band**

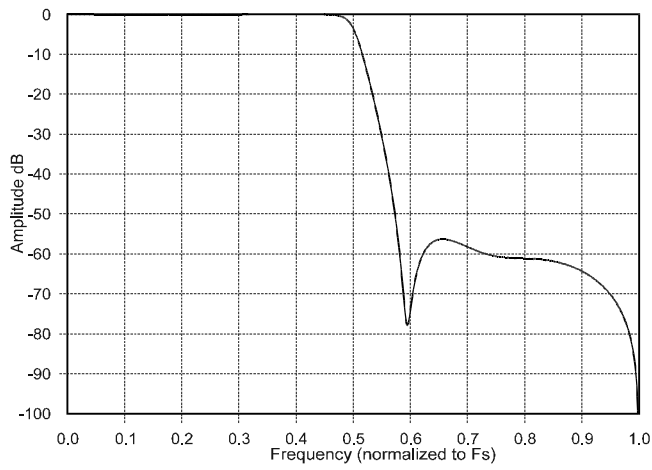
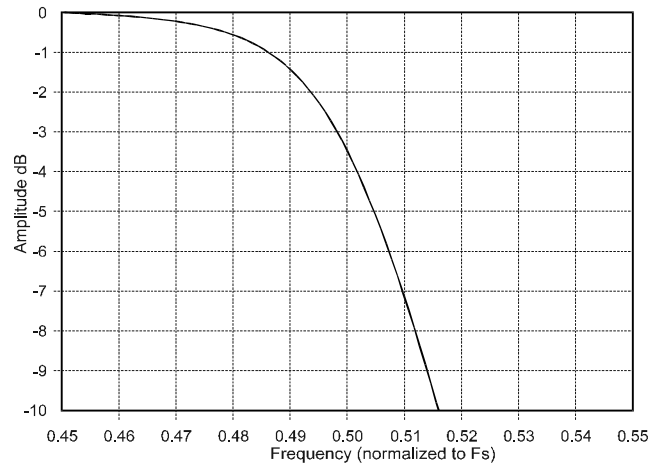
**Figure 24. Double-Speed Transition Band****Figure 25. Double-Speed Stopband Rejection**

## 9. PARAMETER DEFINITIONS

### Total Harmonic Distortion + Noise (THD+N)

The ratio of the rms value of the signal to the rms sum of all other spectral components over the specified bandwidth (typically 10Hz to 20kHz), including distortion components. Expressed in decibels.

### Dynamic Range

The ratio of the full scale rms value of the signal to the rms sum of all other spectral components over the specified bandwidth. Dynamic range is a signal-to-noise measurement over the specified bandwidth made with a -60 dBFS signal. 60 dB is then added to the resulting measurement to refer the measurement to full scale. This technique ensures that the distortion components are below the noise level and do not effect the measurement. This measurement technique has been accepted by the Audio Engineering Society, AES17-1991, and the Electronic Industries Association of Japan, EIAJ CP-307.

### Interchannel Isolation

A measure of crosstalk between the left and right channels. Measured for each channel at the converter's output with all zeros to the input under test and a full-scale signal applied to the other channel. Units in decibels.

### Interchannel Gain Mismatch

The gain difference between left and right channels. Units in decibels.

### Gain Error

The deviation from the nominal full scale analog output for a full scale digital input.

### Gain Drift

The change in gain value with temperature. Units in ppm/°C.

## 10. REFERENCES

1. "How to Achieve Optimum Performance from Delta-Sigma A/D & D/A Converters" by Steven Harris. Paper presented at the 93rd Convention of the Audio Engineering Society, October 1992.
2. CDB4391 Evaluation Board Datasheet
3. "The I<sup>2</sup>C-Bus Specification: Version 2.0" Philips Semiconductors, December 1998. <http://www.semiconductors.philips.com>

**Schematic & Layout Review Service**

Confirm Optimum  
Schematic & Layout  
Before Building Your Board.

For Our Free Review Service  
Call Applications Engineering.

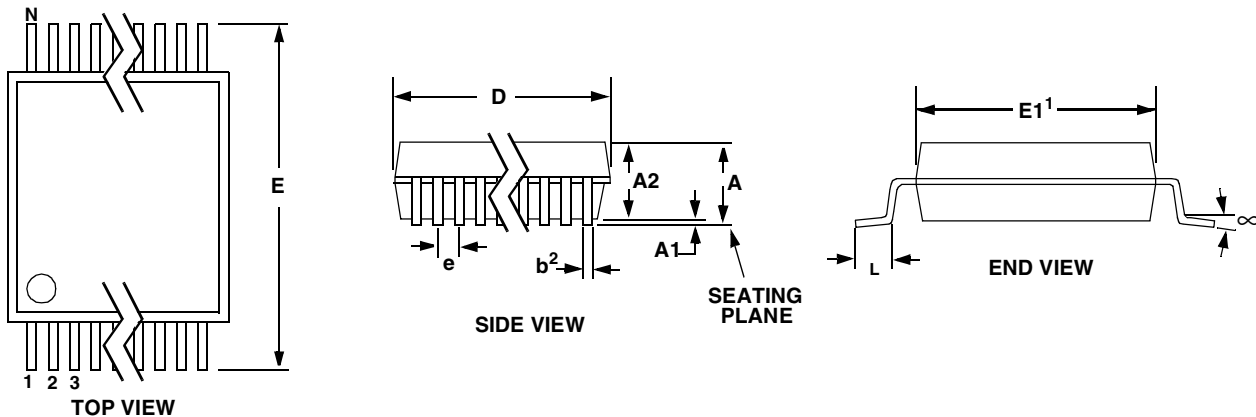

**C a l l : ( 5 1 2 ) 4 4 5 - 7 2 2 2**

**11. PACKAGE DIMENSIONS**
**20L TSSOP (4.4 mm BODY) PACKAGE DRAWING**

DIM	INCHES			MILLIMETERS			NOT E
	MIN	NOM	MAX	MIN	NOM	MAX	
A	--	--	0.043	--	--	1.10	
A1	0.002	0.004	0.006	0.05	--	0.15	
A2	0.03346	0.0354	0.037	0.85	0.90	0.95	
b	0.00748	0.0096	0.012	0.19	0.245	0.30	2,3
D	0.252	0.256	0.259	6.40	6.50	6.60	1
E	0.248	0.2519	0.256	6.30	6.40	6.50	
E1	0.169	0.1732	0.177	4.30	4.40	4.50	1
e	--	--	0.026	--	--	0.65	
L	0.020	0.024	0.028	0.50	0.60	0.70	
$\infty$	0°	4°	8°	0°	4°	8°	

**JEDEC #: MO-153**

Controlling Dimension is Millimeters.

- Notes:
1. "D" and "E1" are reference datums and do not include mold flash or protrusions, but do include mold mismatch and are measured at the parting line, mold flash or protrusions shall not exceed 0.20 mm per side.
  2. Dimension "b" does not include dambar protrusion/intrusion. Allowable dambar protrusion shall be 0.13 mm total in excess of "b" dimension at maximum material condition. Dambar intrusion shall not reduce dimension "b" by more than 0.07 mm at least material condition.
  3. These dimensions apply to the flat section of the lead between 0.10 and 0.25 mm from lead tips.



LittleDiode supplies new, hard to find or obsolete electronic components and semiconductors all over the world.

With over two million different components listed you are sure to find the part you need.

Feel free to visit us today at our online store:

[LittleDiode.com](http://LittleDiode.com)

Looking forward to providing you with the best possible service.