

Single-Phase Single In-Line Bridge Rectifiers

Reverse Voltage 200 to 800V
Forward Current 25A

Case Style GSIB-5S

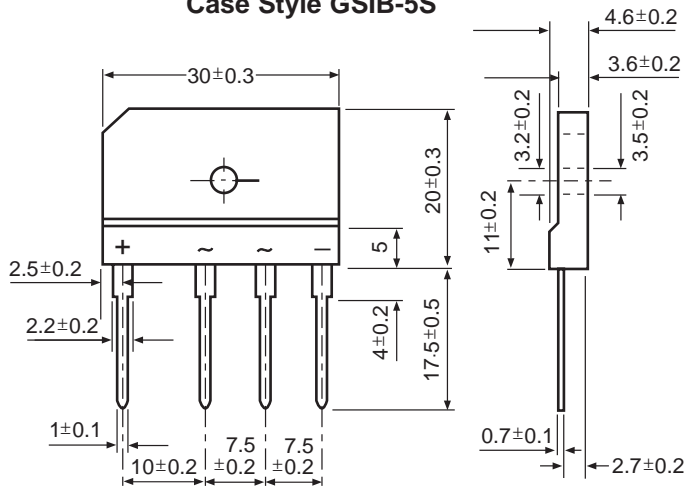

Dimensions in millimeters

Features

- Plastic package has Underwriters Laboratory Flammability Classification 94V-0
- This series is UL listed under the Recognized Component Index, file number E54214.
- High case dielectric strength of 2500 VRMS
- Ideal for printed circuit boards
- Glass passivated chip junction
- High surge current capability

Mechanical Data

Case: GSIB-5S Molded plastic body

Terminals: Plated leads solderable per MIL-STD-750, Method 2026

High temperature soldering guaranteed:
260°C/10 seconds, 0.375 (9.5mm) lead length,
5lbs. (2.3kg) tension

Mounting Position: Any (Note 3)

Mounting Torque: 8 in-lbs max.

Weight: 0.26 oz., 7.0 g

Maximum Ratings & Thermal Characteristics Ratings at 25°C ambient temperature unless otherwise specified.

Parameter	Symbol	GSIB2520	GSIB2540	GSIB2560	GSIB2580	Unit
Maximum repetitive peak reverse voltage	V _{RRM}	200	400	600	800	V
Maximum RMS voltage	V _{RMS}	140	280	420	560	V
Maximum DC blocking voltage	V _{DC}	200	400	600	800	V
Maximum average forward rectified output current at T _C = 98°C T _A = 25°C	I _{F(AV)}	25 ⁽¹⁾ 3.5 ⁽²⁾				A
Peak forward surge current single sine-wave superimposed on rated load (JEDEC Method)	I _{FSM}	350				A
Rating for fusing (t < 8.3ms)	I ² t	500				A ² sec
Maximum thermal resistance per leg	R _{θJA} R _{θJC}	22 ⁽²⁾ 1.0 ⁽¹⁾				°C/W
Operating junction and storage temperature range	T _J , T _{STG}	-55 to +150				°C

Electrical Characteristics Ratings at 25°C ambient temperature unless otherwise specified.

Parameter	Symbol	GSIB2520	GSIB2540	GSIB2560	GSIB2580	Unit
Maximum instantaneous forward voltage drop per leg at 12.5A	V _F	1.00				V
Maximum DC reverse current at rated DC blocking voltage per leg T _A = 25°C T _A = 125°C	I _R	10 350				μA

- Notes:** (1) Unit case mounted on Al plate heatsink
(2) Units mounted on P.C.B. without heatsink
(3) Recommended mounting position is to bolt down on heatsink with silicone thermal compound for maximum heat transfer with #6 screw

Ratings and Characteristic Curves ($T_A = 25^\circ\text{C}$ unless otherwise noted)

Fig. 1 – Derating Curve Output Rectified Current

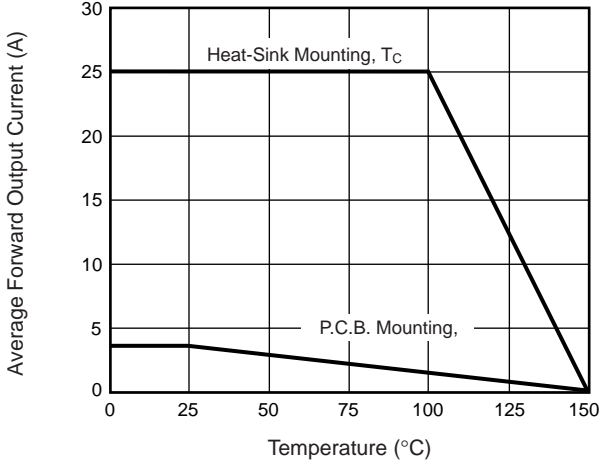

Fig. 2 – Maximum Non-Repetitive Peak Forward Surge Current Per Leg

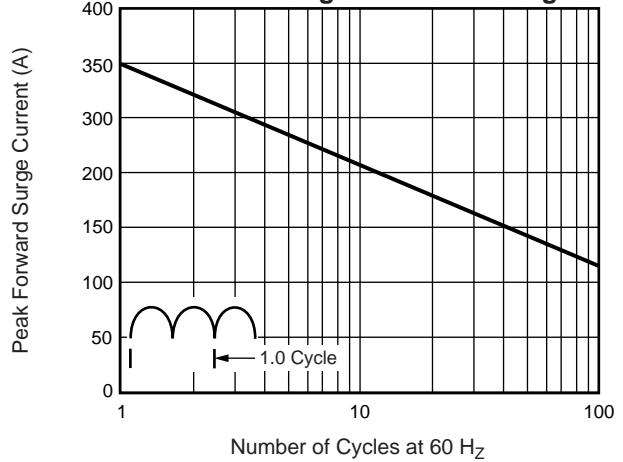

Fig. 3 – Typical Forward Characteristics Per Leg

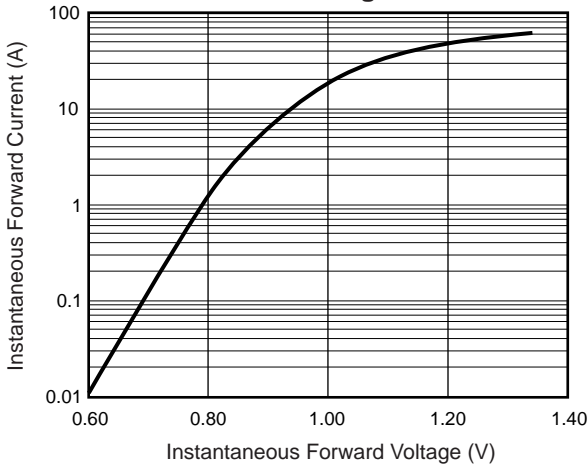

Fig. 4 – Typical Reverse Characteristics Per Leg

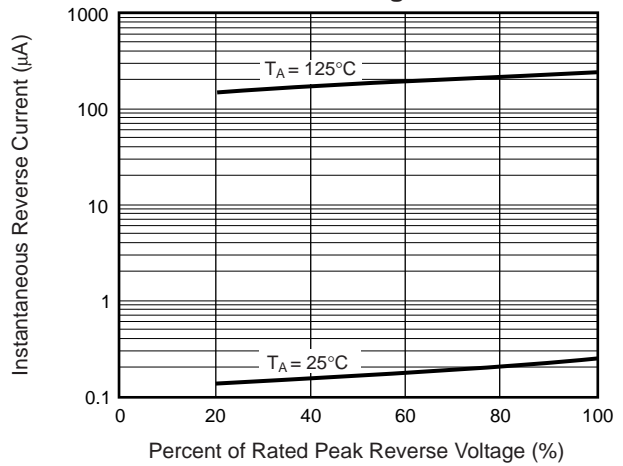

Fig. 5 – Typical Junction Capacitance Per Leg

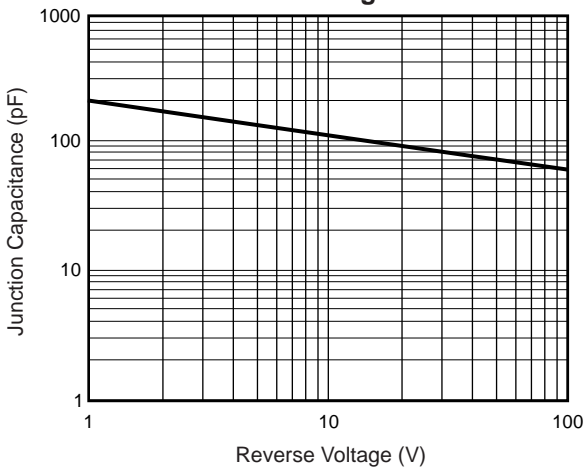
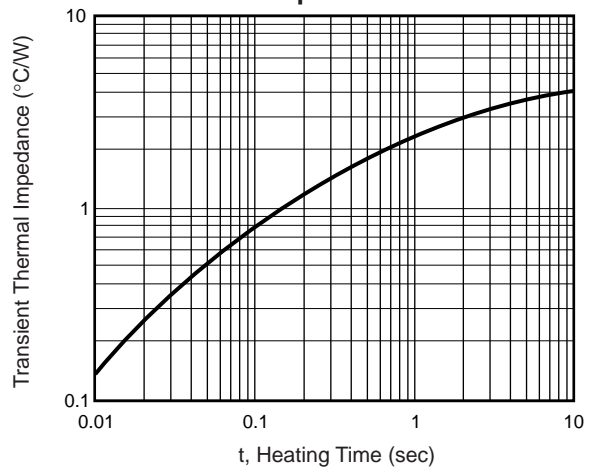

Fig. 6 – Typical Transient Thermal Impedance





LittleDiode supplies new, hard to find or obsolete electronic components and semiconductors all over the world.

With over two million different components listed you are sure to find the part you need.

Feel free to visit us today at our online store:

LittleDiode.com

Looking forward to providing you with the best possible service.