

Datasheet

- \* Single-stage monolithic microwave IC ( MMIC-amplifier )
- \* Cascadable 50 Ω gain block
- \* Application range: 100 MHz to 3 GHz
- \* IP3 30 dBm typ. @ 1.8 GHz
- \* Gain 8.5 dB typ. @ 1.8 GHz
- \* Low noise figure: 3.0 dB typ @ 1.8 GHz
- \* Gain control dynamic range 20 dB

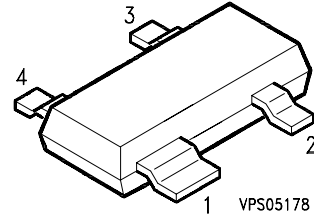

ESD: Electrostatic discharge sensitive device, observe handling precautions!

Type	Marking	Ordering code (tape and reel)	Circuit diagram Pin Configuration	Package 1)
CGY 50	G2	Q68000-A8370		SOT-143

Maximum ratings	Symbol	Value	Unit
Drain-voltage	$V_D$	5.5	V
Peak drain-voltage	$V_{DP}$	7.5	V
Current control gate voltage	$V_G$	-3 ... 0	V
Drain-gate voltage	$V_{DG}$	7.5	V
Input power <sup>2)</sup>	$P_{IN}$	16	dBm
Channel temperature	$T_{Ch}$	150	°C
Storage temperature range	$T_{stg}$	-40...+150	°C
Total power dissipation ( $T_S \leq 82^\circ\text{C}$ ) <sup>3)</sup>	$P_{tot}$	400	mW
<b>Thermal resistance</b>			
Channel-soldering point <sup>3)</sup>	$R_{thChS}$	<170	K/W

**Note:** exceeding any of the max. ratings may cause permanent damage to the device. Appropriate handling is required to protect the electrostatic sensitive MMIC against degradation due to excess current spikes. Proper ground connection of leads 1 and 3 ( with minimum inductance ) is required to achieve the guaranteed RF performance, stable operating conditions and adequate tuning.

1) Dimensions see chapter Package Outlines

2) See application circuit.

3)  $T_s$  is measured on the source 1 lead at the soldering point to the PCB.

**Electrical characteristics**

$T_A = 25\text{ °C}$ ,  $V_G = 0\text{ V}$ ,  $V_D = 4.5\text{ V}$ ,  $R_S = R_L = 50\text{ }\Omega$ , unless otherwise specified

( for application circuit see next page )

Characteristics	Symbol	min	typ	max	Unit
Drain current	$I_D$	-	60	75	mA
Power gain f = 200 MHz f = 1800 MHz	$G$	- 7.5	10.0 8.5	- -	dB
Gain flatness f = 200 to 1000 MHz f = 800 to 1800 MHz	$\Delta G$	- -	0.4 1.1	- 2	dB
Noise figure f = 200 to 1800 MHz	$F$	-	3.0	4.0	dB
Input return loss f = 200 to 1800 MHz	$RL_{IN}$	9.5	12	-	dB
Output return loss f = 200 to 1800 MHz	$RL_{OUT}$	9.5	12	-	dB
Third order intercept point Two tone intermodulation test f <sub>1</sub> = 806 MHz, f <sub>2</sub> = 810 MHz P <sub>0</sub> = 10 dBm ( both carriers )	$IP3$	29	31	-	dBm
1dB gain compression f = 200 to 1800 MHz	$P_{1dB}$	-	16	-	dBm
Gain control dynamic range f = 200 to 1800 MHz	$\Delta G$	-	20	-	dB

Application Circuit ( f = 800 to 1800 MHz )

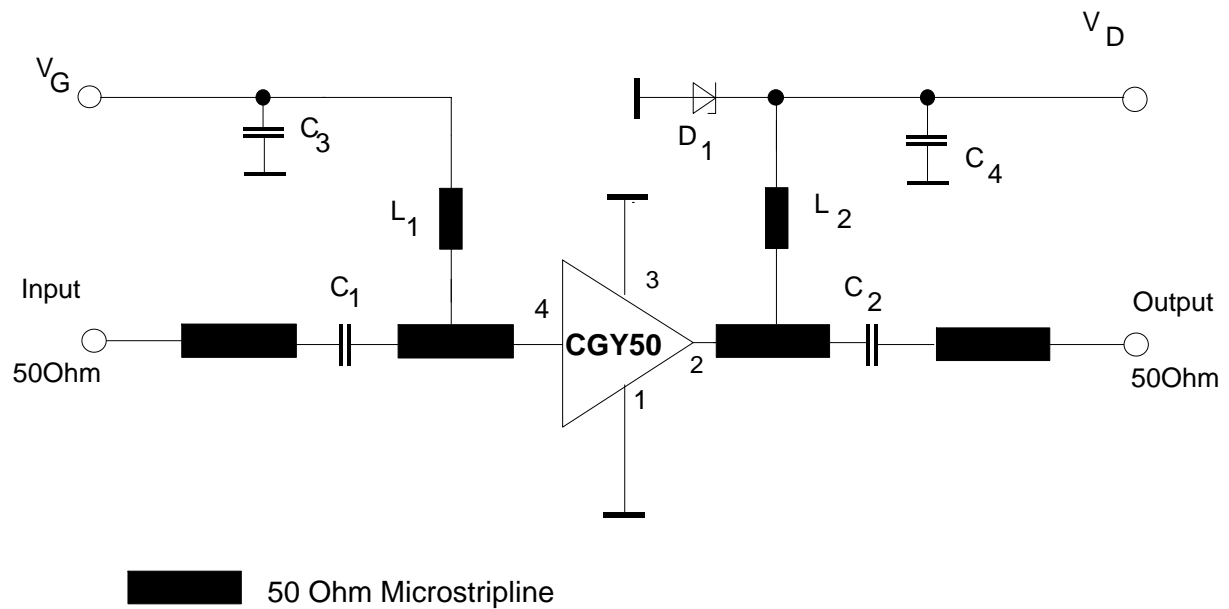

Legend of components

$C_1, C_2$	Chip capacitors 100 pF
$C_3, C_4$	Chip capacitors 1 nF
$L_1, L_2$	Discrete inductor 1 $\mu$ H or printed microstrip inductor
$D_1$	Z diode 5.6 V ( type BZW 22 C5 V 6 )

**Note:** Operating conditions for  $P_{IN, max}$  :  $R_G = R_L = 50 \Omega$ ,  $C_{1, max} = 220 \text{ pF}$ ,  $V_D = 4.5 \text{ V}$ ,  $V_G$  current limited  $< 2 \text{ mA}$ .

Total Power Dissipation  $P_{tot} = f(T_S; T_A)$

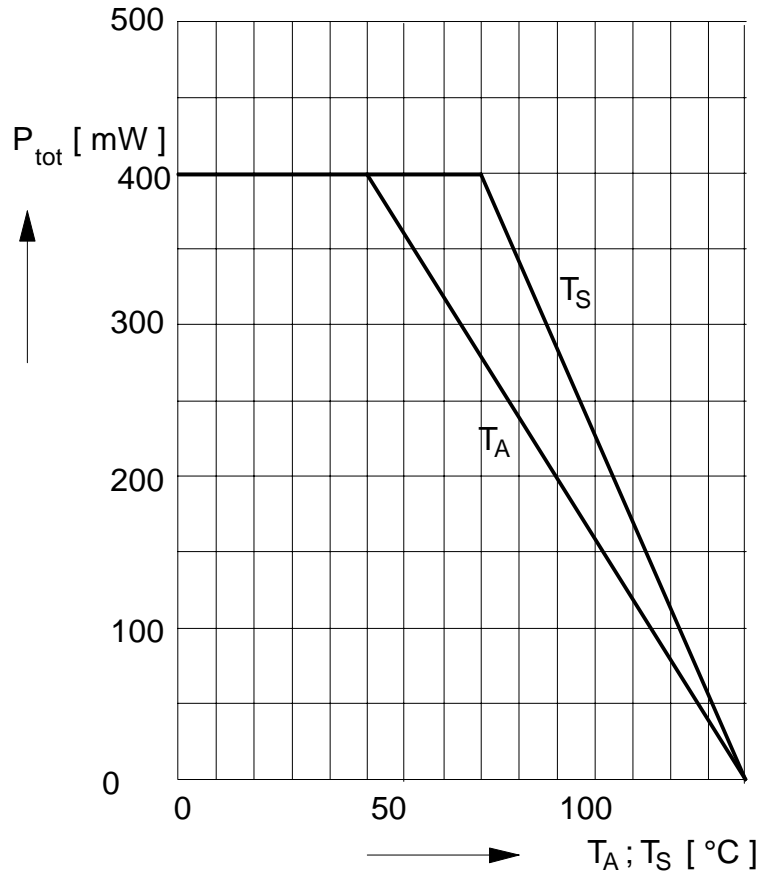

## Typical Common Source S-Parameters

$$V_G = 0V \quad V_D = 4.5V \quad Z_0 = 50\ \Omega$$

f GHz	S11		S21		S12		S22	
	Mag	Ang	Mag	Ang	Mag	Ang	Mag	Ang
0.2	0.25	-31	3.30	164	0.14	5.0	0.05	-144
0.4	0.27	-34	3.20	158	0.14	0.0	0.05	-133
0.6	0.21	-44	3.17	150	0.13	-2.0	0.08	105
0.8	0.20	-54	3.09	142	0.13	-3.0	0.10	91
1.0	0.19	-65	3.00	134	0.13	-4.0	0.12	81
1.2	0.18	-77	2.90	126	0.13	-5.0	0.14	74
1.4	0.18	-93	2.81	118	0.13	-5.0	0.16	68
1.6	0.17	-103	2.70	111	0.13	-6.0	0.17	62
1.8	0.17	-119	2.60	103	0.13	-5.0	0.18	56
2.0	0.17	-130	2.50	96	0.12	-5.0	0.19	51
2.2	0.18	-141	2.42	94	0.12	-4.0	0.20	46
2.4	0.18	-152	2.33	83	0.12	-4.0	0.21	42
2.6	0.19	-163	2.24	77	0.12	-3.0	0.21	39
2.8	0.20	-172	2.16	71	0.13	-3.0	0.21	36
3.0	0.21	179	2.07	65	0.13	-2.0	0.21	33
3.2	0.22	172	2.01	60	0.13	-2.0	0.21	30
3.4	0.23	162	1.94	54	0.13	-2.0	0.21	29
3.6	0.24	153	1.87	49	0.14	-1.0	0.21	28
3.8	0.26	148	1.81	43	0.14	-1.0	0.21	27
4.0	0.28	142	1.75	38	0.15	-1.0	0.20	27



LittleDiode supplies new, hard to find or obsolete electronic components and semiconductors all over the world.

With over two million different components listed you are sure to find the part you need.

Feel free to visit us today at our online store:

[LittleDiode.com](http://LittleDiode.com)

Looking forward to providing you with the best possible service.