

Silizium-PIN-Fotodiode mit Tageslichtsperrfilter
NEU: in SMT und als Reverse Gullwing
Silicon PIN Photodiode with Daylight Filter
NEW: in SMT and as Reverse Gullwing

BPW 34 F
BPW 34 FS
BPW 34 FS (E9087)

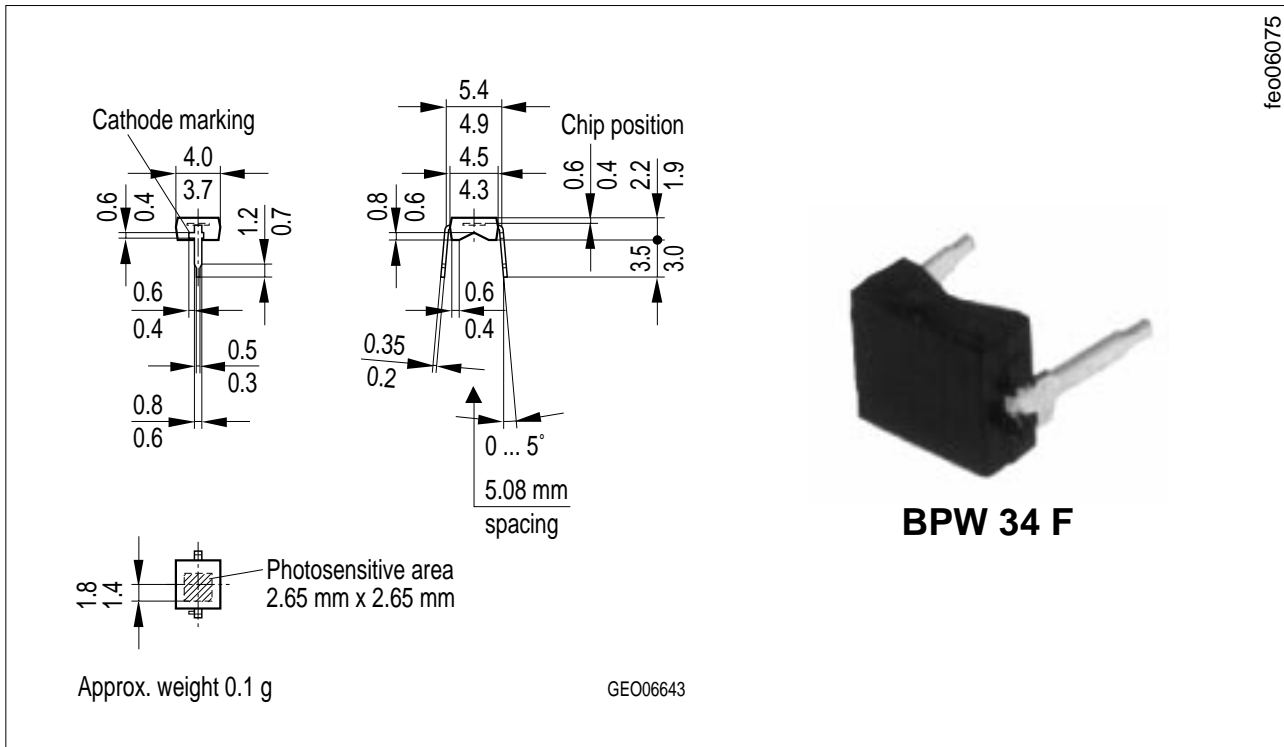

Maße in mm, wenn nicht anders angegeben/Dimensions in mm, unless otherwise specified.

Wesentliche Merkmale

- Speziell geeignet für Anwendungen bei 950 nm
- kurze Schaltzeit (typ. 20 ns)
- DIL-Plastikbauform mit hoher Packungsdichte
- BPW 34 FS/(E9087); geeignet für Vapor-Phase Löten und IR-Reflow Löten

Anwendungen

- IR-Fernsteuerung von Fernseh- und Rundfunkgeräten, Videorecordern, Gerätefernsteuerungen
- Lichtschranken für Gleich- und Wechsellichtbetrieb

Features

- Especially suitable for applications of 950 nm
- Short switching time (typ. 20 ns)
- DIL plastic package with high packing density
- BPW 34 FS/(E9087); suitable for vapor-phase and IR-reflow soldering

Applications

- IR remote control of hi-fi and TV sets, video tape recorders, remote controls of various equipment
- Photointerrupters

feo06861

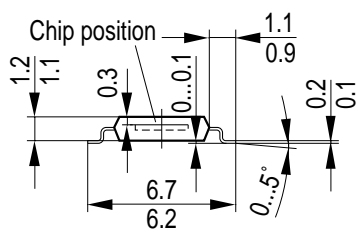

BPW 34 FS

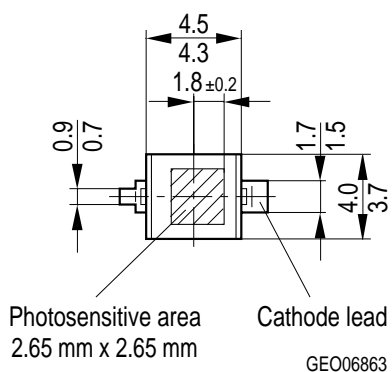

BPW 34 FAS (E9087)

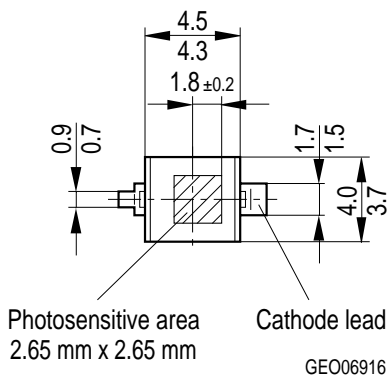
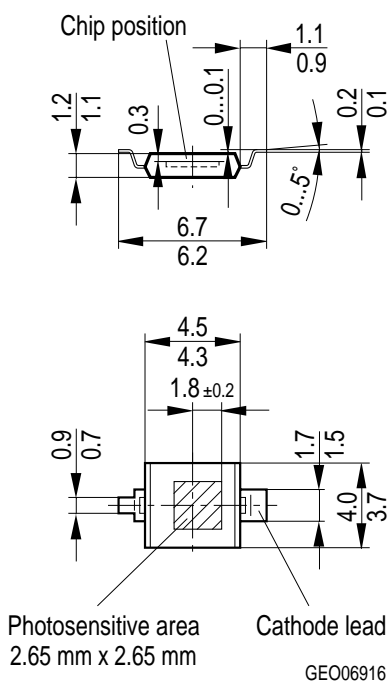

feo06916

Maße in mm, wenn nicht anders angegeben/Dimensions in mm, unless otherwise specified.

Typ Type	Bestellnummer Ordering Code
BPW 34 F	Q62702-P929
BPW 34 FS	Q62702-P1604
BPW 34 FS (E9087)	Q62702-P1826

Grenzwerte Maximum Ratings

Bezeichnung Description	Symbol Symbol	Wert Value	Einheit Unit
Betriebs- und Lagertemperatur Operating and storage temperature range	$T_{op}; T_{stg}$	- 40 ... + 85	°C
Sperrspannung Reverse voltage	V_R	32	V
Verlustleistung, $T_A = 25\text{ °C}$ Total power dissipation	P_{tot}	150	mW

Kennwerte ($T_A = 25\text{ °C}$, $\lambda = 950\text{ nm}$) Characteristics

Bezeichnung Description	Symbol Symbol	Wert Value	Einheit Unit
Fotoempfindlichkeit Spectral sensitivity $V_R = 5\text{ V}$, $E_e = 1\text{ mW/cm}^2$	S	50 (≥ 40)	μA
Wellenlänge der max. Fotoempfindlichkeit Wavelength of max. sensitivity	$\lambda_{S\text{ max}}$	950	nm
Spektraler Bereich der Fotoempfindlichkeit $S = 10\%$ von S_{max} Spectral range of sensitivity $S = 10\%$ of S_{max}	λ	780 ... 1100	nm
Bestrahlungsempfindliche Fläche Radiant sensitive area	A	7.00	mm^2
Abmessung der bestrahlungsempfindlichen Fläche Dimensions of radiant sensitive area	$L \times B$ $L \times W$	2.65×2.65	$\text{mm} \times \text{mm}$
Halbwinkel Half angle	φ	± 60	Grad deg.
Dunkelstrom, $V_R = 10\text{ V}$ Dark current	I_R	2 (≤ 30)	nA
Spektrale Fotoempfindlichkeit Spectral sensitivity	S_λ	0.59	A/W
Quantenausbeute Quantum yield	η	0.77	<u>Electrons</u> Photon
Leerlaufspannung, $E_e = 0.5\text{ mW/cm}^2$ Open-circuit voltage	V_O	330 (≥ 275)	mV

Kennwerte ($T_A = 25\text{ °C}$, $\lambda = 950\text{ nm}$)
Characteristics (cont'd)

Bezeichnung Description	Symbol Symbol	Wert Value	Einheit Unit
Kurzschlußstrom, $E_e = 0.5\text{ mW/cm}^2$ Short-circuit current	I_{SC}	25	μA
Anstiegs- und Abfallzeit des Fotostromes Rise and fall time of the photocurrent $R_L = 50\ \Omega$; $V_R = 5\text{ V}$; $\lambda = 850\text{ nm}$; $I_p = 800\ \mu\text{A}$	t_r, t_f	20	ns
Durchlaßspannung, $I_F = 100\text{ mA}$, $E = 0$ Forward voltage	V_F	1.3	V
Kapazität, $V_R = 0\text{ V}$, $f = 1\text{ MHz}$, $E = 0$ Capacitance	C_0	72	pF
Temperaturkoeffizient von V_O Temperature coefficient of V_O	TC_V	- 2.6	mV/K
Temperaturkoeffizient von I_{SC} Temperature coefficient of I_{SC}	TC_I	0.18	%/K
Rauschäquivalente Strahlungsleistung Noise equivalent power $V_R = 10\text{ V}$	NEP	4.3×10^{-14}	$\frac{\text{W}}{\sqrt{\text{Hz}}}$
Nachweisgrenze, $V_R = 10\text{ V}$ Detection limit	D^*	6.2×10^{12}	$\frac{\text{cm} \cdot \sqrt{\text{Hz}}}{\text{W}}$

Relative spectral sensitivity

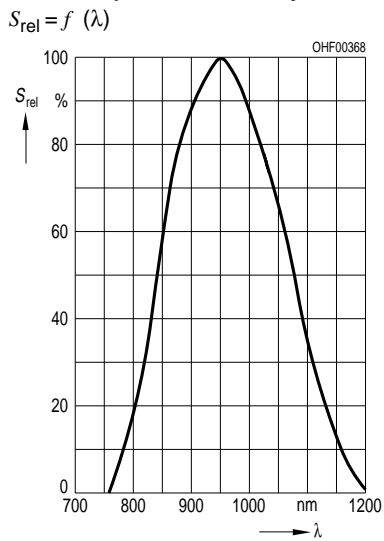

Photocurrent $I_P = f(E_e), V_R = 5 V$ Open-circuit voltage $V_O = f(E_e)$

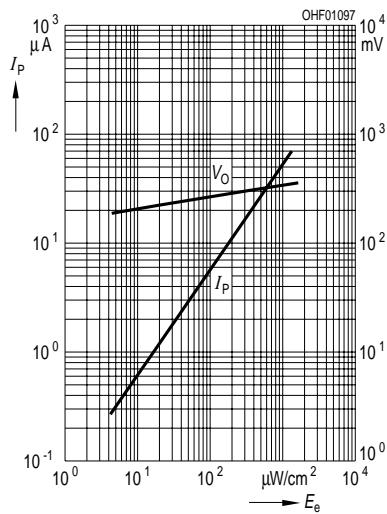

Total power dissipation

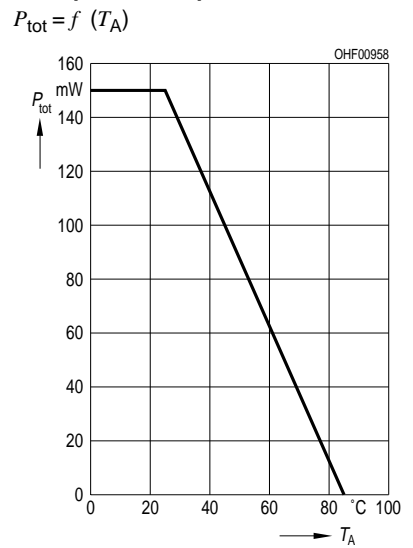

Dark current

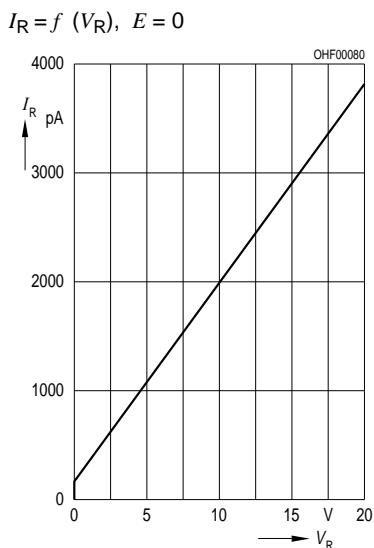

Capacitance

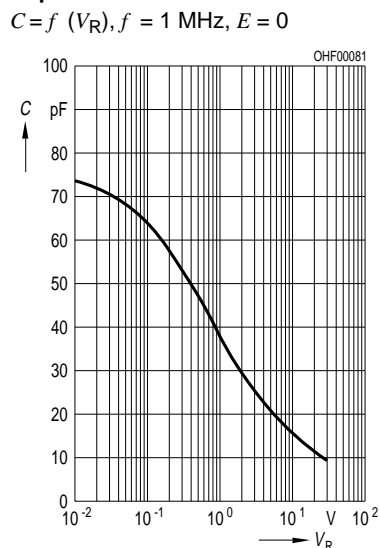

Dark current

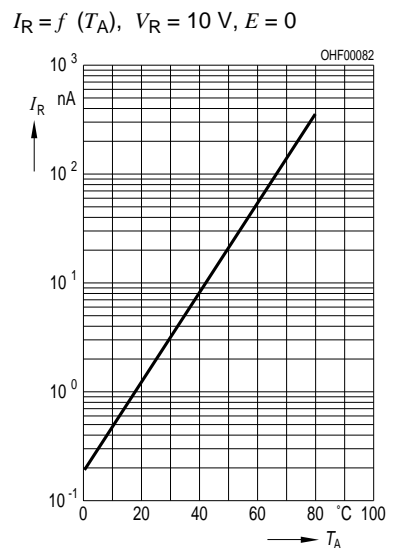

Directional characteristics $S_{rel} = f(\phi)$

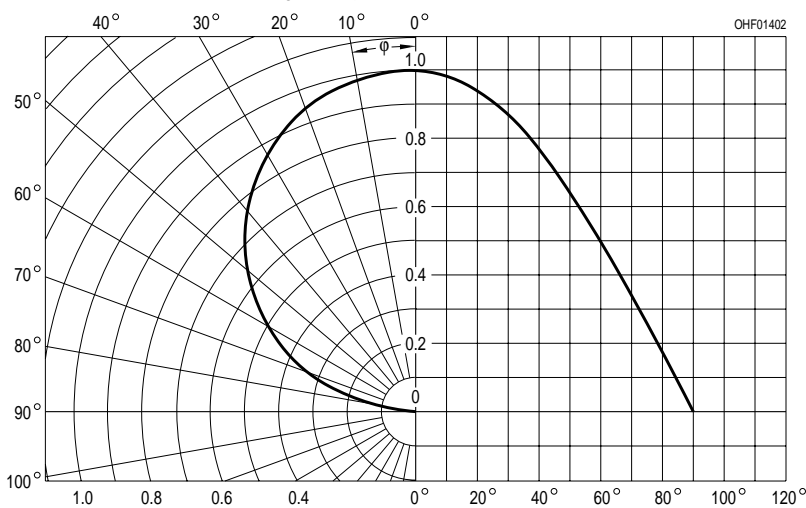



LittleDiode supplies new, hard to find or obsolete electronic components and semiconductors all over the world.

With over two million different components listed you are sure to find the part you need.

Feel free to visit us today at our online store:

LittleDiode.com

Looking forward to providing you with the best possible service.