

DM74ALS125 Quad 3-STATE Buffer

General Description

This device contains four independent gates each of which performs a non-inverting buffer function. The outputs have the 3-STATE feature. The 3-STATE circuitry contains a feature that maintains the buffer outputs in 3-STATE (high impedance state) during power supply ramp-up or ramp-down. This eliminates bus glitching problems that arise during power-up and power-down. To minimize the possibility that two outputs will attempt to take a common bus to opposite logic levels, the disable time is shorter than the enable time of the outputs.

Features

- Advanced low power oxide-isolated ion-implanted Schottky TTL process
- Functional and pin compatible with the 74LS counterpart
- Switching response specified into 500Ω and 50 pF load
- Switching response specifications guaranteed over full temperature and V_{CC} supply range
- PNP input design reduces input loading
- Low level drive current: 74ALS = 24 mA

Ordering Code:

Order Number	Package Number	Package Description
DM74ALS125M	M14A	14-Lead Small Outline Integrated Circuit (SOIC), JEDEC MS-012, 0.150 Narrow
DM74ALS125N	N14A	14-Lead Plastic Dual-In-Line Package (PDIP), JEDEC MS-001, 0.300 Wide

Devices also available in Tape and Reel. Specify by appending the suffix letter "X" to the ordering code.

Connection Diagram

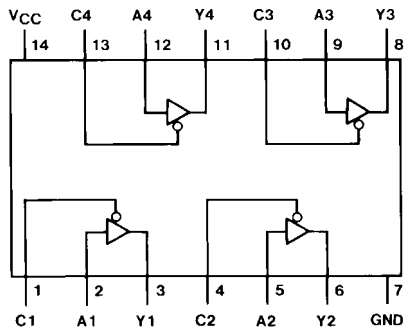

Logic Diagram

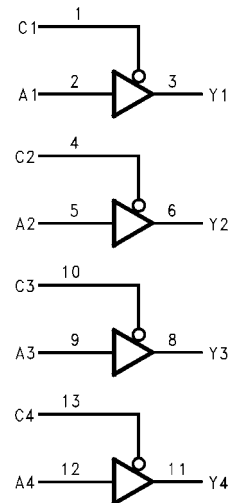

Functional Table

Y = A

Input		Output
A	C	Y
L	L	L
H	L	H
X	H	Hi-Z

H = HIGH Logic Level
L = LOW Logic Level
X = Either LOW or HIGH Logic Level
Hi-Z = 3-STATE (Outputs are disabled)

Absolute Maximum Ratings(Note 1)

Supply Voltage, V_{CC}	7V
Input Voltage	7V
Voltage Applied to Disabled Output	5.5V
Operating Free Air Temperature Range	0 to +70°C
Storage Temperature Range	-65°C to +150°C
Typical θ_{JA}	
N Package	78.0°C/W
M Package	111.0°C/W

Note 1: The Absolute Maximum Ratings are those values beyond which the safety of the device cannot be guaranteed. The device should not be operated at these limits. The parametric values defined in the Electrical Characteristics tables are not guaranteed at the absolute maximum ratings. The "Recommended Operating Conditions" table will define the conditions for actual device operation.

Recommended Operating Conditions

Symbol	Parameter	Min	Typ	Max	Units
V_{CC}	Supply Voltage	4.5	5	5.5	V
V_{IH}	HIGH Level Input Voltage	2			V
V_{IL}	LOW Level Input Voltage			0.8	V
I_{OH}	HIGH Level Output Current			-15	mA
I_{OL}	LOW Level Output Current			24	mA
T_A	Operating Free-Air Temperature	0		70	°C

Electrical Characteristics

over recommended operating free air temperature (unless otherwise specified)

Symbol	Parameter	Conditions	Min	Typ	Max	Units
V_{IK}	Input Clamp Voltage	$V_{CC} = 4.5V, I_I = -18 \text{ mA}$			-1.5	V
V_{OH}	HIGH Level Output Voltage	$V_{CC} = 4.5V \text{ to } 5.5V$	$I_{OH} = -0.4 \text{ mA}$	$V_{CC} - 2$		V
		$V_{CC} = 4.5V$	$I_{OH} = -3 \text{ mA}$	2.4		V
			$I_{OH} = \text{Max}$	2		V
V_{OL}	LOW Level Output Voltage	$V_{CC} = 4.5V$	$I_{OL} = 12 \text{ mA}$	0.25	0.4	V
			$I_{OL} = 24 \text{ mA}$	0.35	0.5	V
I_I	Input Current at Max Input Voltage	$V_{CC} = 5.5V, V_I = 7V$			0.1	mA
I_{IH}	HIGH Level Input Current	$V_{CC} = 5.5V, V_I = 2.7V$			20	μA
I_{IL}	LOW Level Input Current	$V_{CC} = 5.5V, V_{IL} = 0.4V$			-0.1	mA
I_O	Output Drive Current	$V_{CC} = 5.5V, V_O = 2.25V$	-30		-112	mA
I_{OZH}	HIGH Level 3-STATE Output Current	$V_{CC} = 5.5V, V_O = 2.7V$			20	μA
I_{OZL}	LOW Level 3-STATE Output Current	$V_{CC} = 5.5V, V_O = 0.4V$			-20	μA
I_{CC}	Supply Current	$V_{CC} = 5.5V$	Outputs HIGH	7	10	mA
			Outputs LOW	10	14	mA
			3-STATE	13.5	18	mA

Switching Characteristics							
Symbol	Parameter	From (Input)	To (Output)	Conditions	Min	Max	Units
t_{PLH}	Propagation Delay Time LOW-to-HIGH Level Output	A	Y	$V_{CC} = 4.5V$ to $5.5V$, $C_L = 50$ pF, $R1 = 500\Omega$, $R2 = 500\Omega$, $T_A = \text{Min to Max}$	3	10	ns
t_{PHL}	Propagation Delay Time HIGH-to-LOW Level Output	A	Y		2	10	ns
t_{PZH}	Output Enable Time to HIGH Level Output	C	Y		2	13	ns
t_{PZL}	Output Enable Time to LOW Level Output	C	Y		2	12	ns
t_{PHZ}	Output Disable Time from HIGH Level Output	C	Y		1	8	ns
t_{PLZ}	Output Disable Time from LOW Level Output	C	Y		2	13	ns

Physical Dimensions inches (millimeters) unless otherwise noted

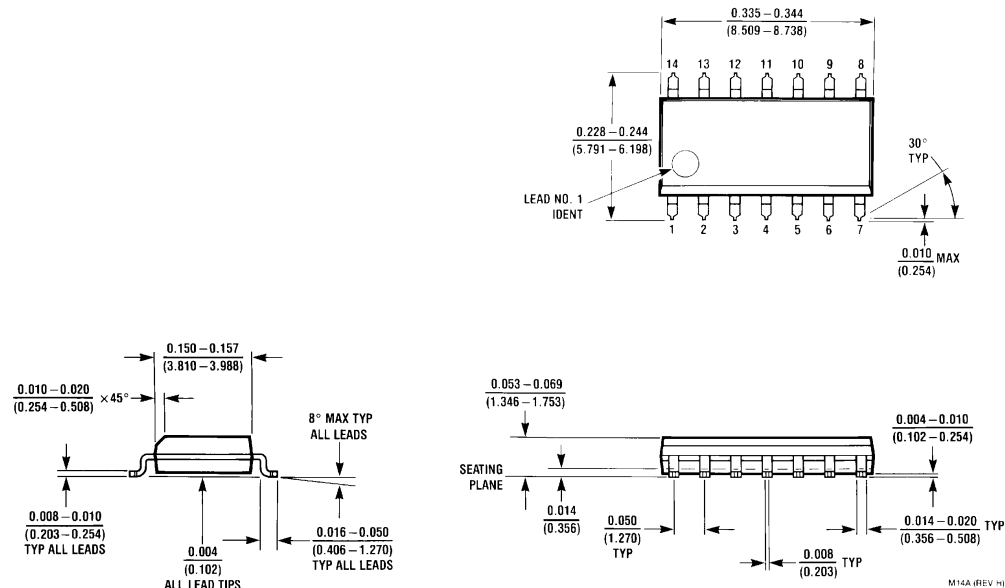

**14-Lead Small Outline Integrated Circuit (SOIC), JEDEC MS-012, 0.150 Narrow
Package Number M14A**

Physical Dimensions inches (millimeters) unless otherwise noted (Continued)

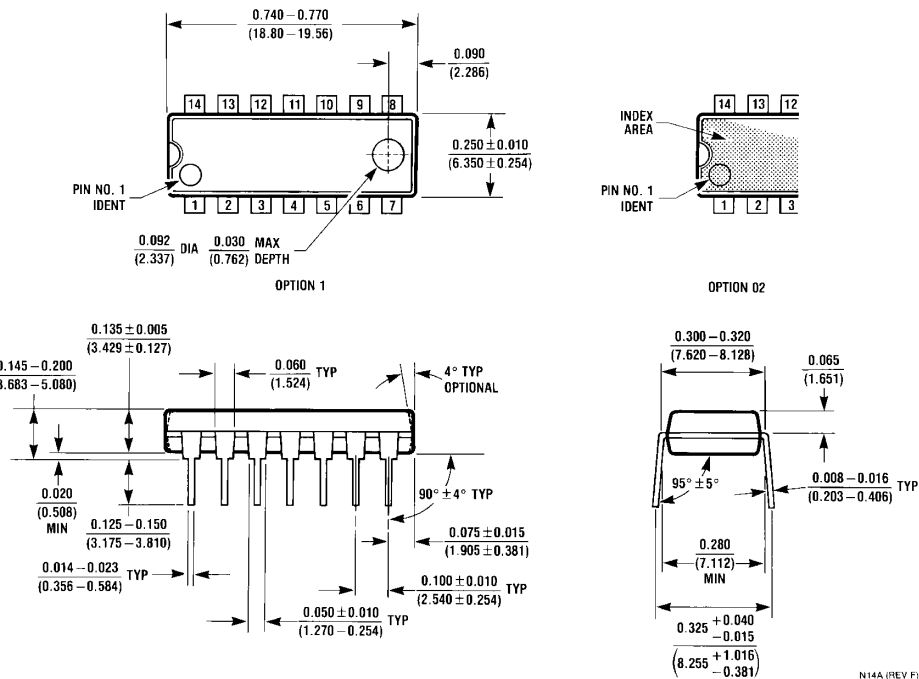

14-Lead Plastic Dual-In-Line Package (PDIP), JEDEC MS-001, 0.300 Wide Package Number N14A

Fairchild does not assume any responsibility for use of any circuitry described, no circuit patent licenses are implied and Fairchild reserves the right at any time without notice to change said circuitry and specifications.

LIFE SUPPORT POLICY

FAIRCHILD'S PRODUCTS ARE NOT AUTHORIZED FOR USE AS CRITICAL COMPONENTS IN LIFE SUPPORT DEVICES OR SYSTEMS WITHOUT THE EXPRESS WRITTEN APPROVAL OF THE PRESIDENT OF FAIRCHILD SEMICONDUCTOR CORPORATION. As used herein:

1. Life support devices or systems are devices or systems which, (a) are intended for surgical implant into the body, or (b) support or sustain life, and (c) whose failure to perform when properly used in accordance with instructions for use provided in the labeling, can be reasonably expected to result in a significant injury to the user.
2. A critical component in any component of a life support device or system whose failure to perform can be reasonably expected to cause the failure of the life support device or system, or to affect its safety or effectiveness.

www.fairchildsemi.com



LittleDiode supplies new, hard to find or obsolete electronic components and semiconductors all over the world.

With over two million different components listed you are sure to find the part you need.

Feel free to visit us today at our online store:

LittleDiode.com

Looking forward to providing you with the best possible service.