



# 74ACT244

## OCTAL BUS BUFFER WITH 3 STATE OUTPUTS (NON INVERTED)

- HIGH SPEED:  $t_{PD} = 4.5 \text{ ns}$  (TYP.) at  $V_{CC} = 5V$
- LOW POWER DISSIPATION:  
 $I_{CC} = 8 \mu\text{A}$  (MAX.) at  $T_A = 25^\circ\text{C}$
- COMPATIBLE WITH TTL OUTPUTS  
 $V_{IH} = 2V$  (MIN),  $V_{IL} = 0.8V$  (MAX)
- $50\Omega$  TRANSMISSION LINE DRIVING CAPABILITY
- SYMMETRICAL OUTPUT IMPEDANCE:  
 $|I_{OH}| = I_{OL} = 24 \text{ mA}$  (MIN)
- BALANCED PROPAGATION DELAYS:  
 $t_{PLH} \cong t_{PHL}$
- OPERATING VOLTAGE RANGE:  
 $V_{CC}$  (OPR) = 4.5V to 5.5V
- PIN AND FUNCTION COMPATIBLE WITH 74 SERIES 244
- IMPROVED LATCH-UP IMMUNITY

### DESCRIPTION

The ACT244 is an advanced CMOS OCTAL BUS BUFFER (3-STATE) fabricated with sub-micron silicon gate and double-layer metal wiring  $C^2$ MOS technology. It is ideal for low power applications maintaining high speed operation similar to equivalent Bipolar Schottky TTL.

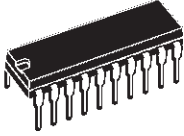

**B**  
(Plastic Package)

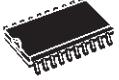

**M**  
(Micro Package)

**ORDER CODES :**  
 74ACT244B  
 74ACT244M  
 74ACT244T



**T**  
(TSSOP Package)

$\overline{G}$  control output governs four BUS BUFFERs.  
 This device is designed to be used with 3 state memory address drivers, etc.

The device is designed to interface directly High Speed CMOS systems with TTL, NMOS and CMOS output voltage levels.

All inputs and outputs are equipped with protection circuits against static discharge, giving them 2KV ESD immunity and transient excess voltage.

### PIN CONNECTION AND IEC LOGIC SYMBOLS

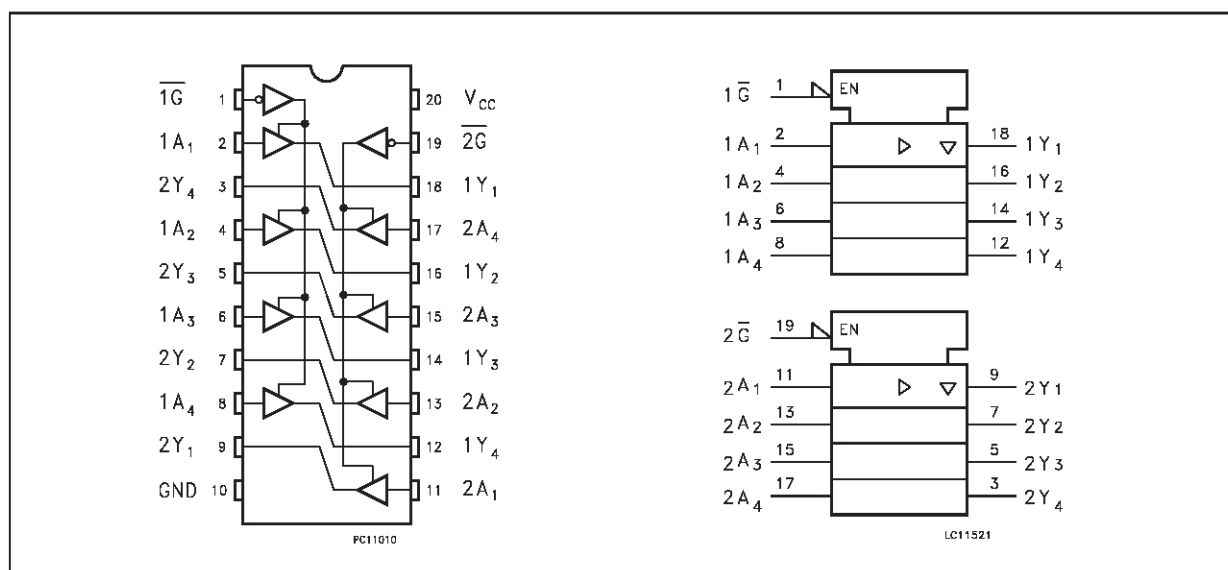

INPUT AND OUTPUT EQUIVALENT CIRCUIT

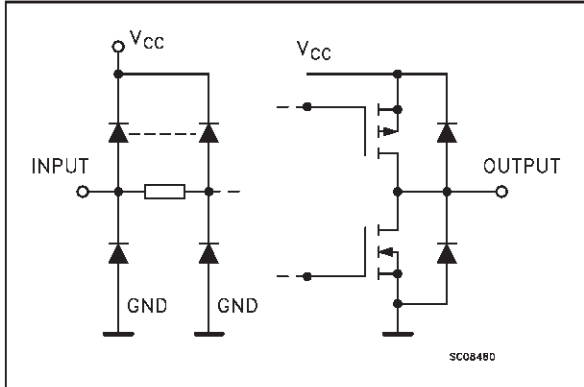

PIN DESCRIPTION

PIN No	SYMBOL	NAME AND FUNCTION
1	$\overline{1G}$	Output Enable Input
2, 4, 6, 8	1A1 to 1A4	Data Inputs
9, 7, 5, 3	2Y1 to 2Y4	Data Outputs
11, 13, 15, 17	2A1 to 2A4	Data Inputs
18, 16, 14, 12	1Y1 to 1Y4	Data Outputs
19	$\overline{2G}$	Output Enabel Input
10	GND	Ground (0V)
20	V <sub>CC</sub>	Positive Supply Voltage

TRUTH TABLE

INPUT		OUTPUT
$\overline{G}$	A <sub>n</sub>	Y <sub>n</sub>
L	L	L
L	H	H
H	X	Z

X: "H" or "L"  
Z: High impedance

ABSOLUTE MAXIMUM RATINGS

Symbol	Parameter	Value	Unit
V <sub>CC</sub>	Supply Voltage	-0.5 to +7	V
V <sub>I</sub>	DC Input Voltage	-0.5 to V <sub>CC</sub> + 0.5	V
V <sub>O</sub>	DC Output Voltage	-0.5 to V <sub>CC</sub> + 0.5	V
I <sub>IK</sub>	DC Input Diode Current	±20	mA
I <sub>OK</sub>	DC Output Diode Current	±20	mA
I <sub>O</sub>	DC Output Current	±50	mA
I <sub>CC</sub> or I <sub>GND</sub>	DC V <sub>CC</sub> or Ground Current	±400	mA
T <sub>stg</sub>	Storage Temperature	-65 to +150	°C
T <sub>L</sub>	Lead Temperature (10 sec)	300	°C

Absolute Maximum Ratings are those values beyond which damage to the device may occur. Functional operation under these condition is not implied.

RECOMMENDED OPERATING CONDITIONS

Symbol	Parameter	Value	Unit
V <sub>CC</sub>	Supply Voltage	4.5 to 5.5	V
V <sub>I</sub>	Input Voltage	0 to V <sub>CC</sub>	V
V <sub>O</sub>	Output Voltage	0 to V <sub>CC</sub>	V
T <sub>op</sub>	Operating Temperature:	-40 to +85	°C
dt/dv	Input Rise and Fall Time V <sub>CC</sub> = 4.5 to 5.5V (note 1)	8	ns/V

1) V<sub>IN</sub> from 0.8V to 2.0V

## DC SPECIFICATIONS

Symbol	Parameter	Test Conditions		Value					Unit
				T <sub>A</sub> = 25 °C			-40 to 85 °C		
				V <sub>CC</sub> (V)	Min.	Typ.	Max.	Min.	
V <sub>IH</sub>	High Level Input Voltage	4.5	V <sub>O</sub> = 0.1 V or V <sub>CC</sub> - 0.1 V	2.0	1.5		2.0		V
		5.5		2.0	1.5		2.0		
V <sub>IL</sub>	Low Level Input Voltage	4.5	V <sub>O</sub> = 0.1 V or V <sub>CC</sub> - 0.1 V		1.5	0.8		0.8	V
		5.5			1.5	0.8		0.8	
V <sub>OH</sub>	High Level Output Voltage	4.5	V <sub>I</sub> <sup>(*)</sup> = V <sub>IH</sub> or V <sub>IL</sub>	I <sub>O</sub> = -50 μA	4.4	4.49		4.4	V
		5.5		I <sub>O</sub> = -50 μA	5.4	5.49		5.4	
		4.5		I <sub>O</sub> = -24 mA	3.86			3.76	
		5.5		I <sub>O</sub> = -24 mA	4.86			4.76	
V <sub>OL</sub>	Low Level Output Voltage	4.5	V <sub>I</sub> <sup>(*)</sup> = V <sub>IH</sub> or V <sub>IL</sub>	I <sub>O</sub> = 50 μA		0.001	0.1	0.1	V
		5.5		I <sub>O</sub> = 50 mA		0.001	0.1	0.1	
		4.5		I <sub>O</sub> = 24 mA			0.36	0.44	
		5.5		I <sub>O</sub> = 24 mA			0.36	0.44	
I <sub>I</sub>	Input Leakage Current	5.5	V <sub>I</sub> = V <sub>CC</sub> or GND			±0.1		±1	μA
I <sub>OZ</sub>	3 State Output Leakage Current	5.5	V <sub>I</sub> = V <sub>IH</sub> or V <sub>IL</sub> V <sub>O</sub> = V <sub>CC</sub> or GND			±0.5		±5	μA
I <sub>CCR</sub>	Max I <sub>CC</sub> /Input	5.5	V <sub>I</sub> = V <sub>CC</sub> - 2.1 V		0.6			1.5	mA
I <sub>CC</sub>	Quiescent Supply Current	5.5	V <sub>I</sub> = V <sub>CC</sub> or GND			8		80	μA
I <sub>OLD</sub>	Dynamic Output Current (note 1, 2)	5.5	V <sub>OLD</sub> = 1.65 V max				75		mA
I <sub>OHD</sub>			V <sub>OHD</sub> = 3.85 V min				-75		mA

1) Maximum test duration 2ms, one output loaded at time

2) Incident wave switching is guaranteed on transmission lines with impedances as low as 50 Ω.

(\*) All outputs loaded.

# 74ACT244

## AC ELECTRICAL CHARACTERISTICS ( $C_L = 50 \text{ pF}$ , $R_L = 500 \Omega$ , Input $t_r = t_f = 3 \text{ ns}$ )

Symbol	Parameter	Test Condition		Value					Unit	
				$V_{CC}$ (V)	$T_A = 25 \text{ }^\circ\text{C}$			$-40 \text{ to } 85 \text{ }^\circ\text{C}$		
					Min.	Typ.	Max.	Min.		Max.
$t_{PLH}$ $t_{PHL}$	Propagation Delay Time	$5.0^{(*)}$		1.5	4.5	9.0	1.5	10.0	ns	
$t_{PZL}$ $t_{PZH}$	Output Enable Time	$5.0^{(*)}$		1.5	5.5	9.0	1.5	10.0	ns	
$t_{PLZ}$ $t_{PHZ}$	Output Disable Time	$5.0^{(*)}$		1.5	6.5	10.0	1.5	11.0	ns	

(\*) Voltage range is  $5V \pm 0.5V$

## CAPACITIVE CHARACTERISTICS

Symbol	Parameter	Test Conditions		Value					Unit	
				$V_{CC}$ (V)	$T_A = 25 \text{ }^\circ\text{C}$			$-40 \text{ to } 85 \text{ }^\circ\text{C}$		
					Min.	Typ.	Max.	Min.		Max.
$C_{IN}$	Input Capacitance	5.0			4				pF	
$C_{iO}$	I/O Capacitance	5.0			8				pF	
$C_{PD}$	Power Dissipation Capacitance (note 1)	5.0			24				pF	

1)  $C_{PD}$  is defined as the value of the IC's internal equivalent capacitance which is calculated from the operating current consumption without load. (Refer to Test Circuit). Average operating current can be obtained by the following equation.  $I_{CC(oper)} = C_{PD} \cdot V_{CC} \cdot f_{IN} + I_{CC0}/n$  (per circuit)

## TEST CIRCUIT

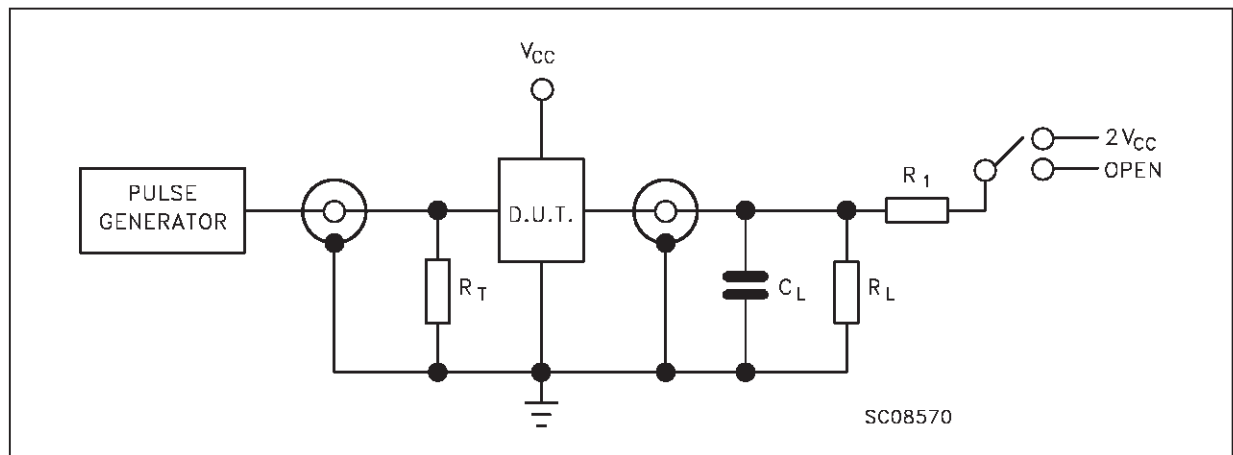

TEST	SWITCH
$t_{PLH}$ , $t_{PHL}$	Open
$t_{PZL}$ , $t_{PLZ}$	$2V_{CC}$
$t_{PZH}$ , $t_{PHZ}$	Open

$C_L = 50 \text{ pF}$  or equivalent (includes jig and probe capacitance)

$R_L = R_1 = 500 \Omega$  or equivalent

$R_T = Z_{out}$  of pulse generator (typically  $50 \Omega$ )

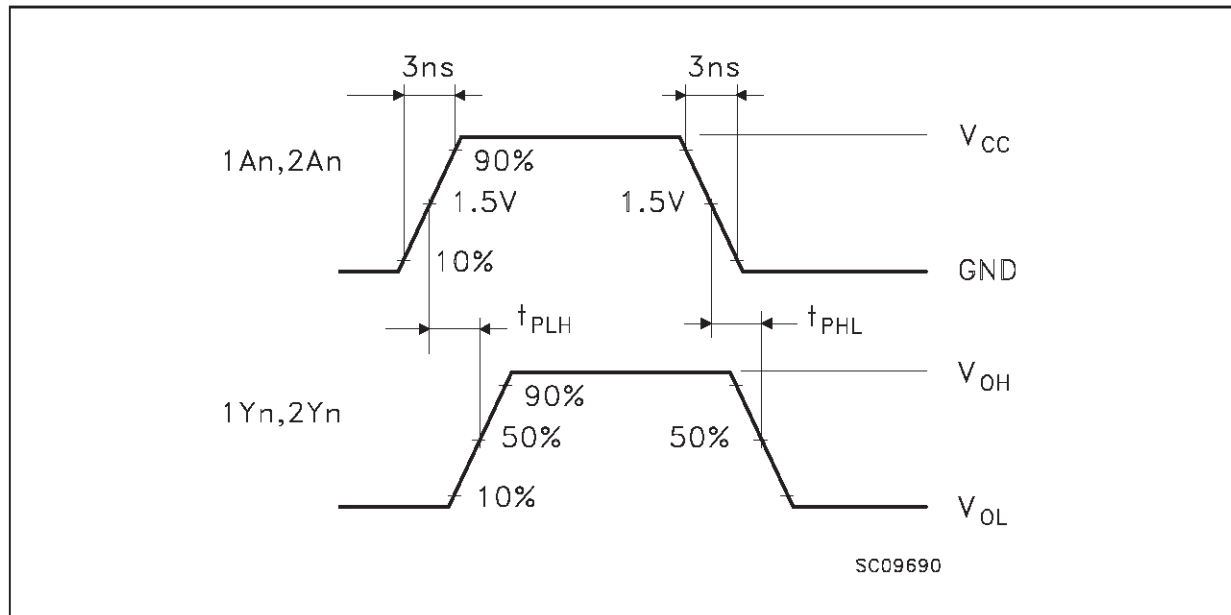
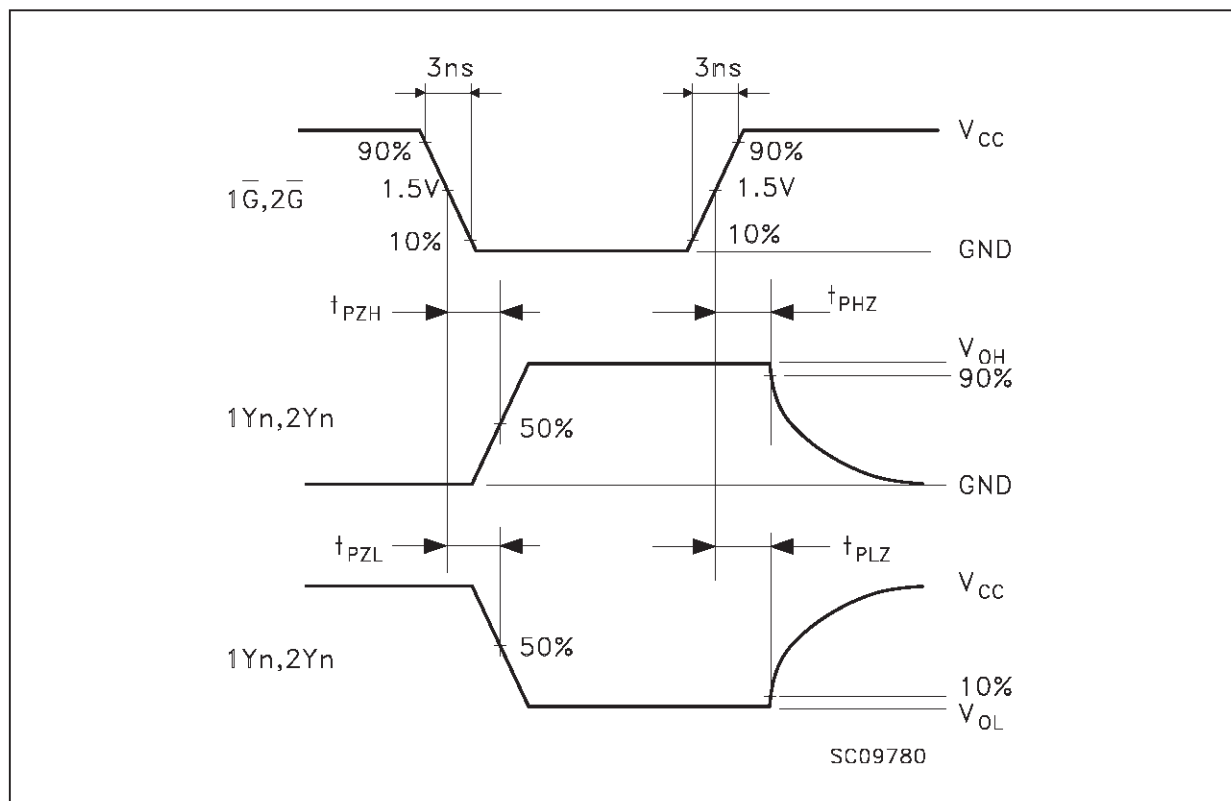
**WAVEFORM 1: PROPAGATION DELAYS** (f=1MHz; 50% duty cycle)**WAVEFORM 2: OUTPUT ENABLE AND DISABLE TIME** (f=1MHz; 50% duty cycle)

**Plastic DIP-20 (0.25) MECHANICAL DATA**

DIM.	mm			inch		
	MIN.	TYP.	MAX.	MIN.	TYP.	MAX.
a1	0.254			0.010		
B	1.39		1.65	0.055		0.065
b		0.45			0.018	
b1		0.25			0.010	
D			25.4			1.000
E		8.5			0.335	
e		2.54			0.100	
e3		22.86			0.900	
F			7.1			0.280
l			3.93			0.155
L		3.3			0.130	
Z			1.34			0.053

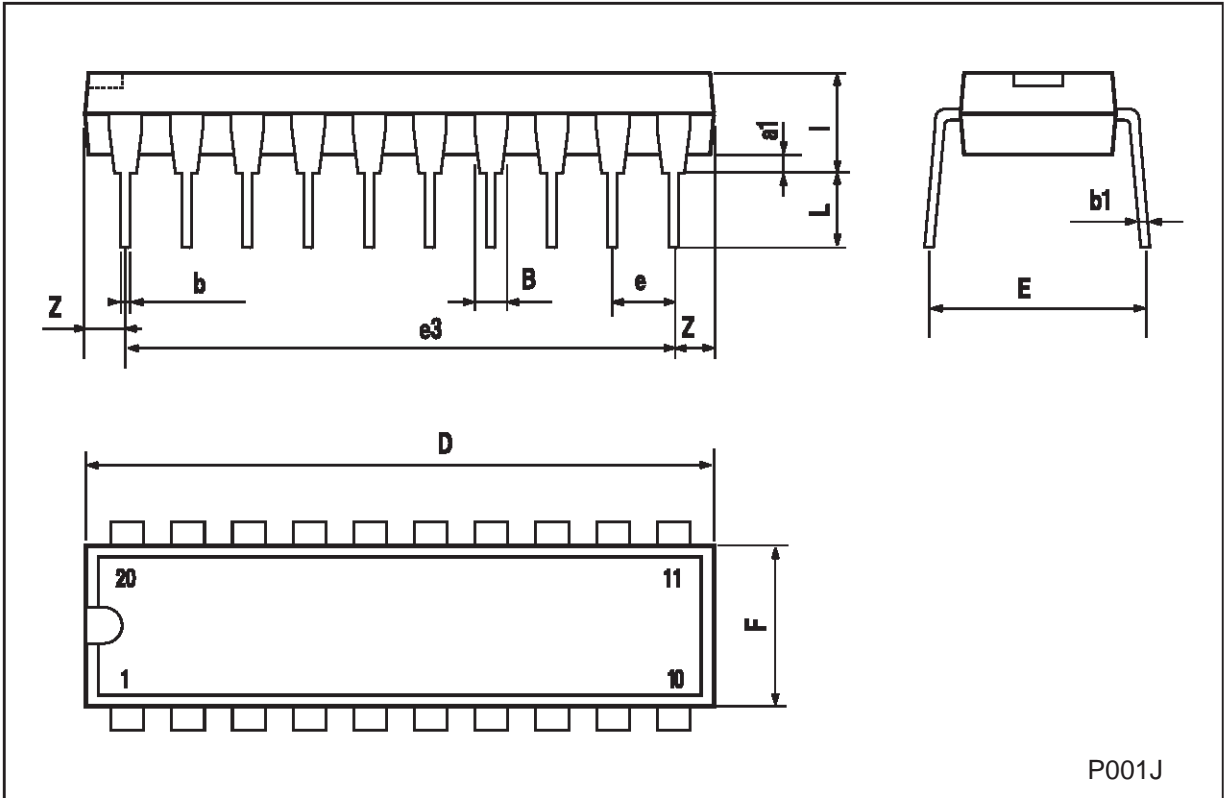

P001J



## SO-20 MECHANICAL DATA

DIM.	mm			inch		
	MIN.	TYP.	MAX.	MIN.	TYP.	MAX.
A			2.65			0.104
a1	0.10		0.20	0.004		0.007
a2			2.45			0.096
b	0.35		0.49	0.013		0.019
b1	0.23		0.32	0.009		0.012
C		0.50			0.020	
c1	45 (typ.)					
D	12.60		13.00	0.496		0.512
E	10.00		10.65	0.393		0.419
e		1.27			0.050	
e3		11.43			0.450	
F	7.40		7.60	0.291		0.299
L	0.50		1.27	0.19		0.050
M			0.75			0.029
S	8 (max.)					

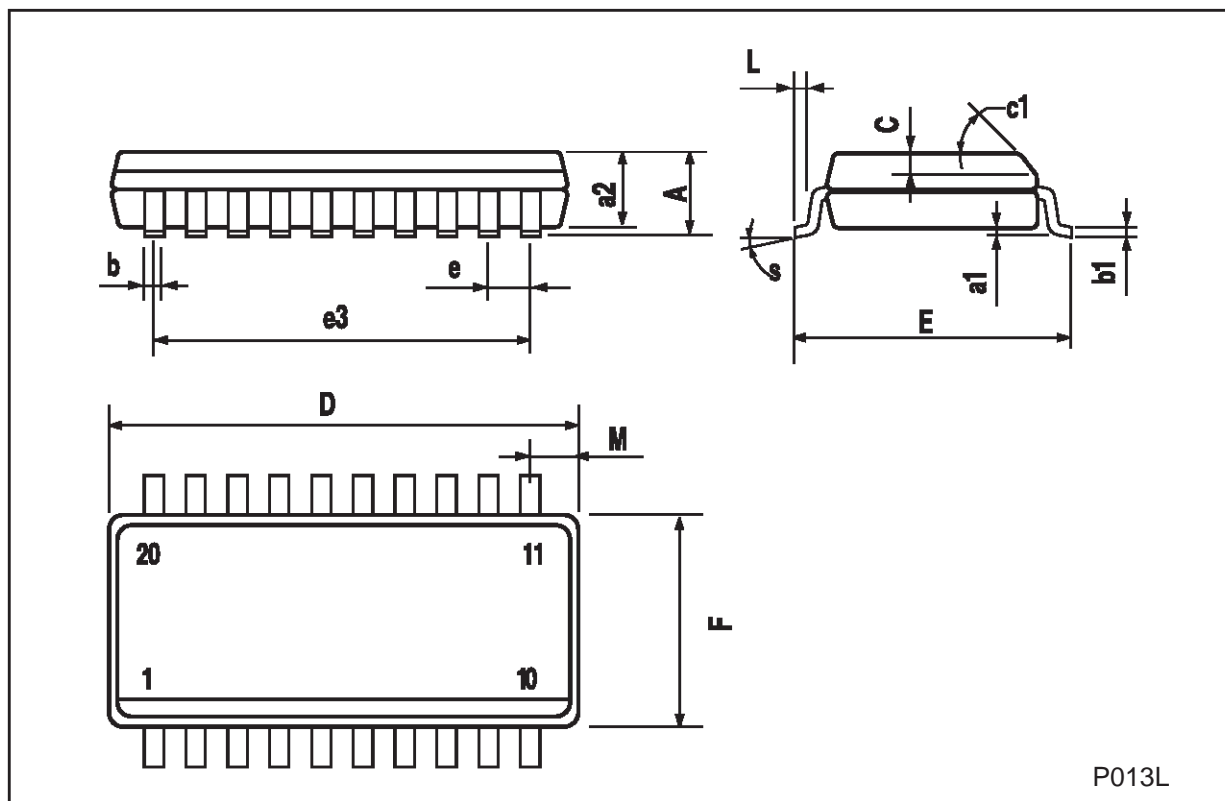

**TSSOP20 MECHANICAL DATA**

DIM.	mm			inch		
	MIN.	TYP.	MAX.	MIN.	TYP.	MAX.
A			1.1			0.433
A1	0.05	0.10	0.15	0.002	0.004	0.006
A2	0.85	0.9	0.95	0.335	0.354	0.374
b	0.19		0.30	0.0075		0.0118
c	0.09		0.2	0.0035		0.0079
D	6.4	6.5	6.6	0.252	0.256	0.260
E	6.25	6.4	6.5	0.246	0.252	0.256
E1	4.3	4.4	4.48	0.169	0.173	0.176
e		0.65 BSC			0.0256 BSC	
K	0°	4°	8°	0°	4°	8°
L	0.50	0.60	0.70	0.020	0.024	0.028

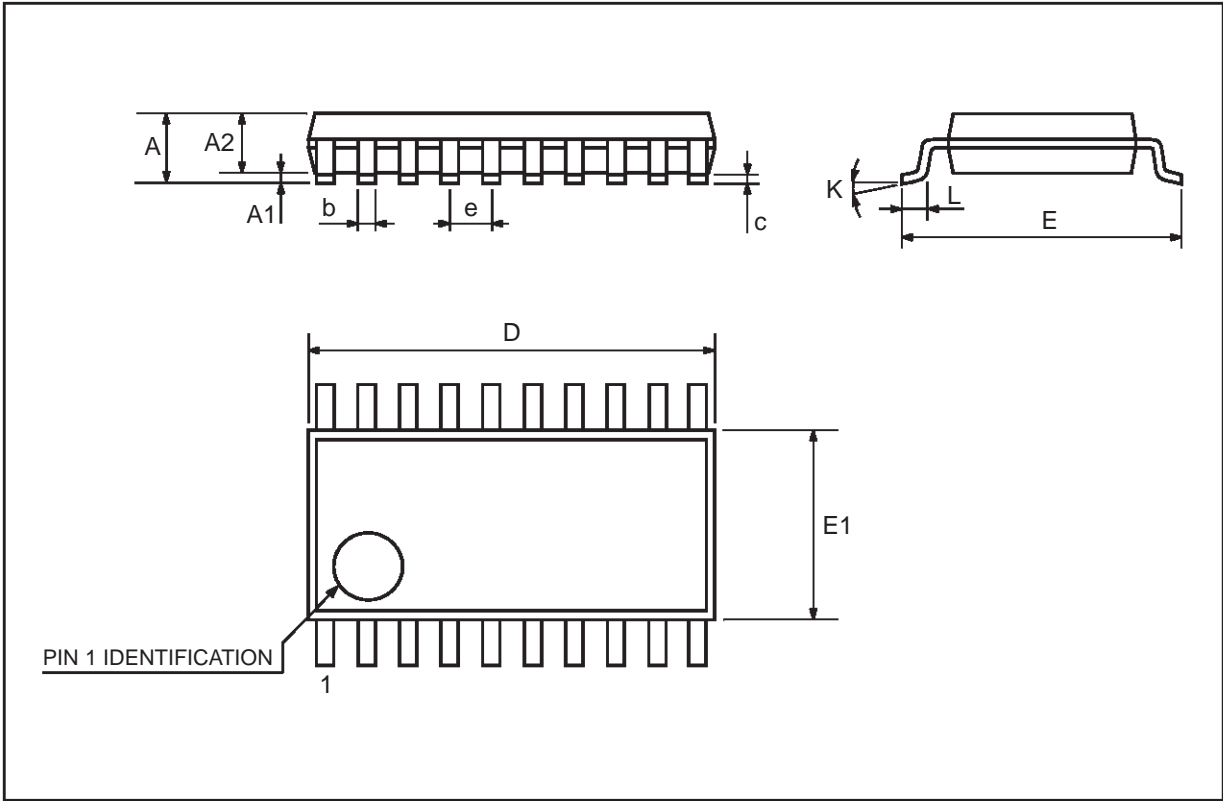

Information furnished is believed to be accurate and reliable. However, STMicroelectronics assumes no responsibility for the consequences of use of such information nor for any infringement of patents or other rights of third parties which may result from its use. No license is granted by implication or otherwise under any patent or patent rights of STMicroelectronics. Specification mentioned in this publication are subject to change without notice. This publication supersedes and replaces all information previously supplied. STMicroelectronics products are not authorized for use as critical components in life support devices or systems without express written approval of STMicroelectronics.

The ST logo is a trademark of STMicroelectronics

© 1999 STMicroelectronics – Printed in Italy – All Rights Reserved

STMicroelectronics GROUP OF COMPANIES

Australia - Brazil - Canada - China - France - Germany - Italy - Japan - Korea - Malaysia - Malta - Mexico - Morocco - The Netherlands - Singapore - Spain - Sweden - Switzerland - Taiwan - Thailand - United Kingdom - U.S.A.

<http://www.st.com>

This datasheet has been downloaded from:

[www.DatasheetCatalog.com](http://www.DatasheetCatalog.com)

Datasheets for electronic components.



LittleDiode supplies new, hard to find or obsolete electronic components and semiconductors all over the world.

With over two million different components listed you are sure to find the part you need.

Feel free to visit us today at our online store:

[LittleDiode.com](http://LittleDiode.com)

Looking forward to providing you with the best possible service.