

# FDP8880 / FDB8880

## N-Channel PowerTrench® MOSFET

30V, 54A, 11.6mΩ

### Features

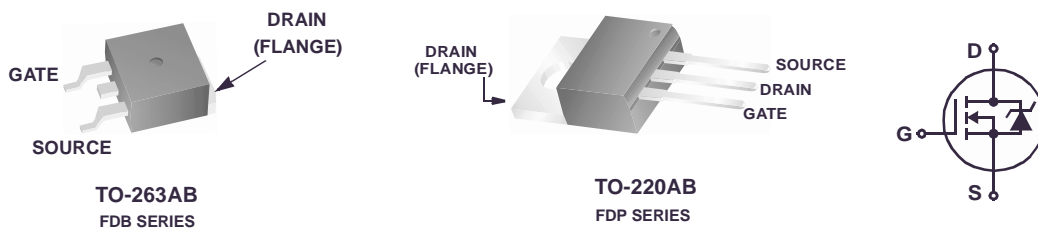
- $r_{DS(ON)} = 14.5m\Omega$ ,  $V_{GS} = 4.5V$ ,  $I_D = 40A$
- $r_{DS(ON)} = 11.6m\Omega$ ,  $V_{GS} = 10V$ ,  $I_D = 40A$
- High performance trench technology for extremely low  $r_{DS(ON)}$
- Low gate charge
- High power and current handling capability

### General Description

This N-Channel MOSFET has been designed specifically to improve the overall efficiency of DC/DC converters using either synchronous or conventional switching PWM controllers. It has been optimized for low gate charge, low  $r_{DS(ON)}$  and fast switching speed.

### Applications

- DC/DC converters



### MOSFET Maximum Ratings $T_C = 25^\circ\text{C}$ unless otherwise noted

Symbol	Parameter	Ratings	Units
$V_{DSS}$	Drain to Source Voltage	30	V
$V_{GS}$	Gate to Source Voltage	$\pm 20$	V
$I_D$	Drain Current		
	Continuous ( $T_C = 25^\circ\text{C}$ , $V_{GS} = 10\text{V}$ )	54	A
	Continuous ( $T_C = 25^\circ\text{C}$ , $V_{GS} = 4.5\text{V}$ )	48	A
	Continuous ( $T_{amb} = 25^\circ\text{C}$ , $V_{GS} = 10\text{V}$ , with $R_{\theta JA} = 43^\circ\text{C/W}$ )	11	A
	Pulsed	Figure 4	A
$E_{AS}$	Single Pulse Avalanche Energy (Note 1)	31	mJ
$P_D$	Power dissipation	55	W
	Derate above $25^\circ\text{C}$	0.37	W/ $^\circ\text{C}$
$T_J, T_{STG}$	Operating and Storage Temperature	-55 to 175	$^\circ\text{C}$

### Thermal Characteristics

$R_{\theta JC}$	Thermal Resistance Junction to Case TO-220, TO-263	2.73	$^\circ\text{C/W}$
$R_{\theta JA}$	Thermal Resistance Junction to Ambient TO-220, TO-262 ( Note 2)	62	$^\circ\text{C/W}$
$R_{\theta JA}$	Thermal Resistance Junction to Ambient TO-263, 1in <sup>2</sup> copper pad area	43	$^\circ\text{C/W}$

### Package Marking and Ordering Information

Device Marking	Device	Package	Reel Size	Tape Width	Quantity
FDP8880	FDP8880	TO-220AB	Tube	N/A	50 units
FDB8880	FDB8880	TO-263AB	330mm	24mm	800 units
FDP8880	FDP8880_NL (Note 3)	TO-220AB	Tube	N/A	50 units
FDB8880	FDB8880_NL (Note 3)	TO-263AB	330mm	24mm	800 units

### Electrical Characteristics $T_C = 25^\circ\text{C}$ unless otherwise noted

Symbol	Parameter	Test Conditions	Min	Typ	Max	Units
--------	-----------	-----------------	-----	-----	-----	-------

#### Off Characteristics

$B_{VDSS}$	Drain to Source Breakdown Voltage	$I_D = 250\mu\text{A}$ , $V_{GS} = 0\text{V}$	30	-	-	V
$I_{DSS}$	Zero Gate Voltage Drain Current	$V_{DS} = 24\text{V}$	-	-	1	$\mu\text{A}$
		$V_{GS} = 0\text{V}$ $T_C = 150^\circ\text{C}$	-	-	250	
$I_{GSS}$	Gate to Source Leakage Current	$V_{GS} = \pm 20\text{V}$	-	-	$\pm 100$	nA

#### On Characteristics

$V_{GS(TH)}$	Gate to Source Threshold Voltage	$V_{GS} = V_{DS}$ , $I_D = 250\mu\text{A}$	1.2	-	2.5	V
$r_{DS(ON)}$	Drain to Source On Resistance	$I_D = 40\text{A}$ , $V_{GS} = 10\text{V}$	-	0.0095	0.0116	$\Omega$
		$I_D = 40\text{A}$ , $V_{GS} = 4.5\text{V}$	-	0.012	0.0145	
		$I_D = 40\text{A}$ , $V_{GS} = 10\text{V}$ , $T_J = 175^\circ\text{C}$	-	0.015	0.019	

### Dynamic Characteristics

$C_{ISS}$	Input Capacitance	$V_{DS} = 15V, V_{GS} = 0V,$ $f = 1MHz$	-	1240	-	pF	
$C_{OSS}$	Output Capacitance		-	255	-	pF	
$C_{RSS}$	Reverse Transfer Capacitance		-	147	-	pF	
$R_G$	Gate Resistance	$V_{GS} = 0.5V, f = 1MHz$	-	2.7	-	$\Omega$	
$Q_{g(TOT)}$	Total Gate Charge at 10V	$V_{GS} = 0V$ to 10V	$V_{DD} = 15V$ $I_D = 40A$ $I_g = 1.0mA$	-	22	29	nC
$Q_{g(5)}$	Total Gate Charge at 5V	$V_{GS} = 0V$ to 5V		-	12	16	nC
$Q_{g(TH)}$	Threshold Gate Charge	$V_{GS} = 0V$ to 1V		-	1.6	2.1	nC
$Q_{gs}$	Gate to Source Gate Charge			-	3.2	-	nC
$Q_{gs2}$	Gate Charge Threshold to Plateau			-	2.0	-	nC
$Q_{gd}$	Gate to Drain "Miller" Charge			-	4.8	-	nC

### Switching Characteristics ( $V_{GS} = 10V$ )

$t_{ON}$	Turn-On Time	$V_{DD} = 15V, I_D = 40A$ $V_{GS} = 10V, R_{GS} = 13.6\Omega$	-	-	171	ns
$t_{d(ON)}$	Turn-On Delay Time		-	8	-	ns
$t_r$	Rise Time		-	107	-	ns
$t_{d(OFF)}$	Turn-Off Delay Time		-	47	-	ns
$t_f$	Fall Time		-	51	-	ns
$t_{OFF}$	Turn-Off Time		-	-	147	ns

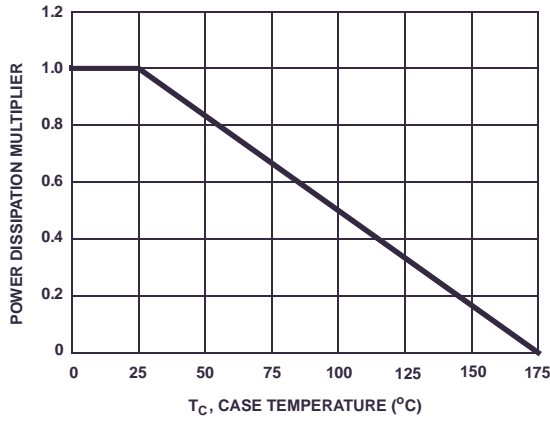
### Drain-Source Diode Characteristics

$V_{SD}$	Source to Drain Diode Voltage	$I_{SD} = 40A$	-	-	1.25	V
		$I_{SD} = 3.5A$	-	-	1.0	V
$t_{rr}$	Reverse Recovery Time	$I_{SD} = 40A, di_{SD}/dt = 100A/\mu s$	-	-	27	ns
$Q_{RR}$	Reverse Recovered Charge	$I_{SD} = 40A, di_{SD}/dt = 100A/\mu s$	-	-	18	nC

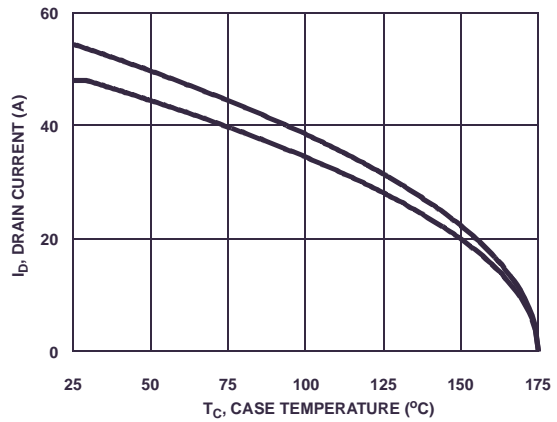
**Notes:**

- 1: Starting  $T_J = 25^\circ C, L = 34\mu H, I_{AS} = 43A, V_{dd} = 27V, V_{gs} = 10V.$
- 2: Pulse width = 100s.
- 3: FDP8880\_NL / FDB8880\_NL is lead free product.  
FDP8880\_NL / FDB8880\_NL marking will appear on the reel label.

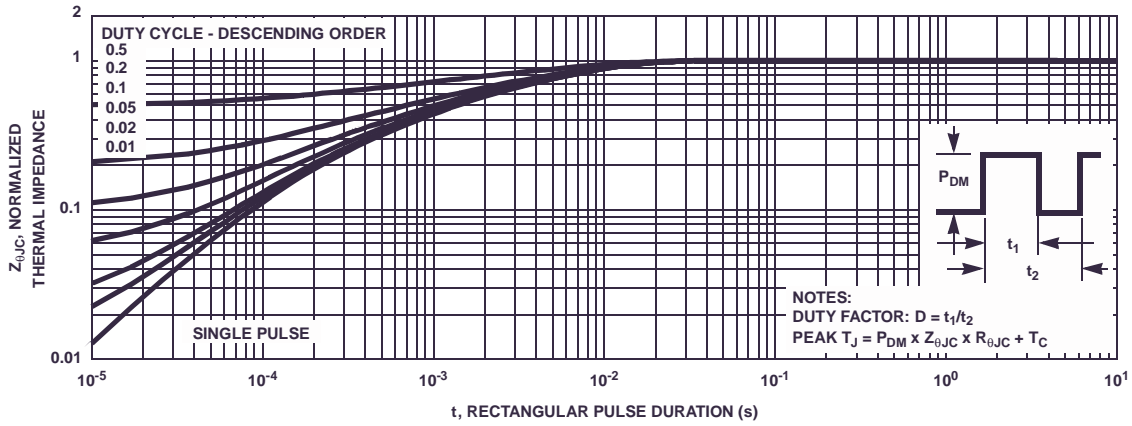
**Typical Characteristics**  $T_C = 25^\circ\text{C}$  unless otherwise noted



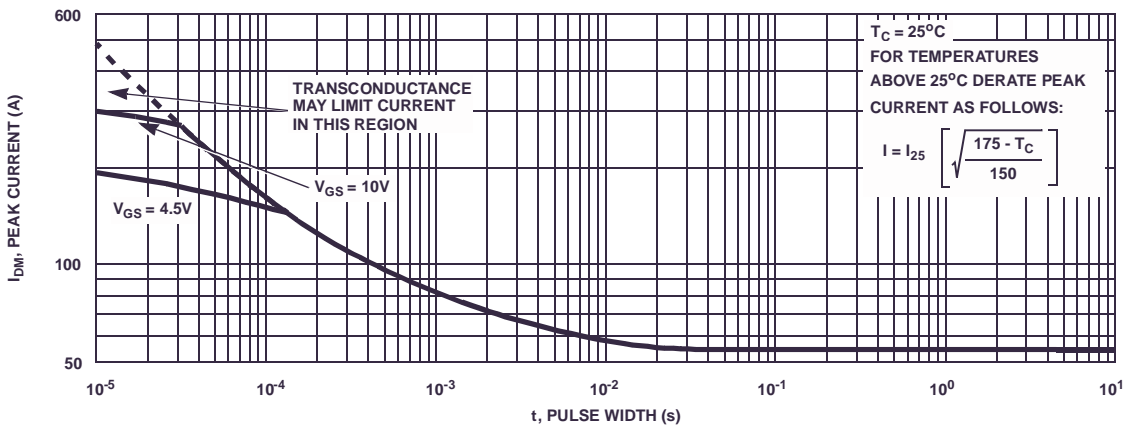
**Figure 1. Normalized Power Dissipation vs Case Temperature**



**Figure 2. Maximum Continuous Drain Current vs Case Temperature**

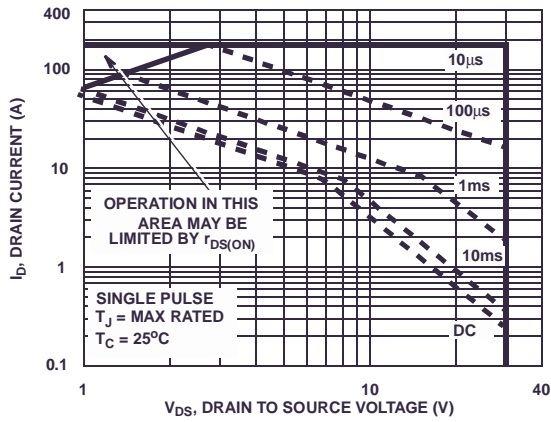


**Figure 3. Normalized Maximum Transient Thermal Impedance**

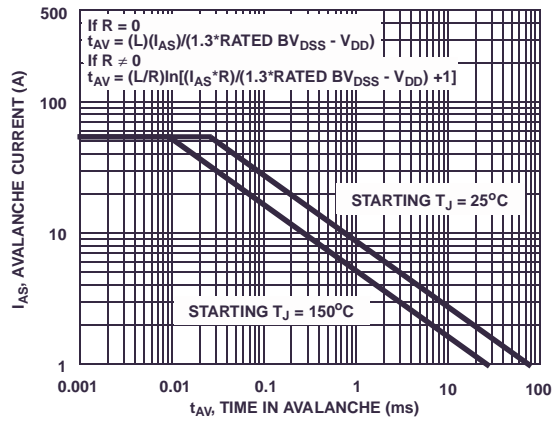


**Figure 4. Peak Current Capability**

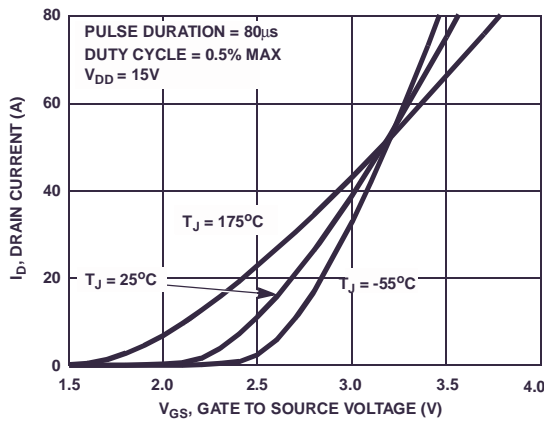
**Typical Characteristics**  $T_C = 25^\circ\text{C}$  unless otherwise noted



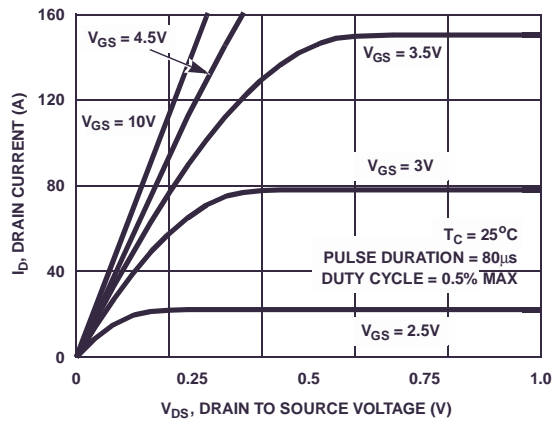
**Figure 5. Forward Bias Safe Operating Area**



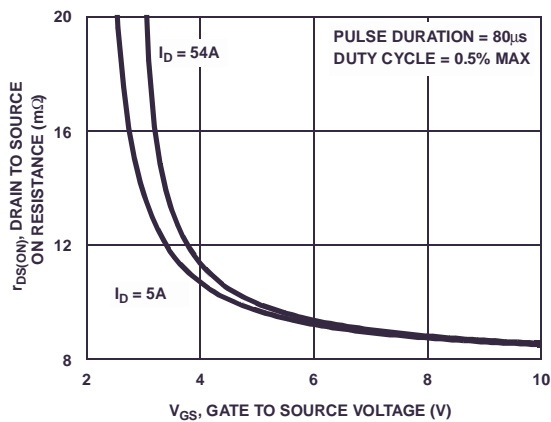
NOTE: Refer to Fairchild Application Notes AN7514 and AN7515  
**Figure 6. Unclamped Inductive Switching Capability**



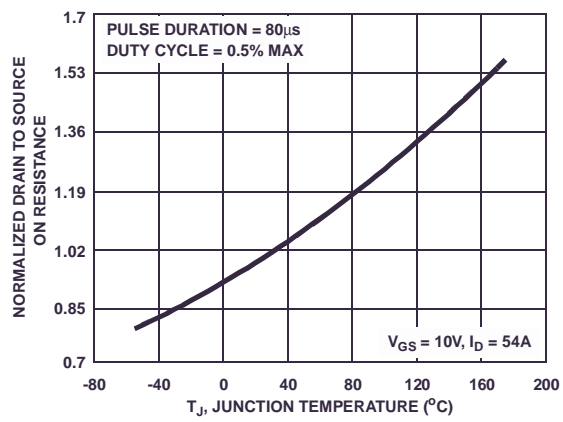
**Figure 7. Transfer Characteristics**



**Figure 8. Saturation Characteristics**

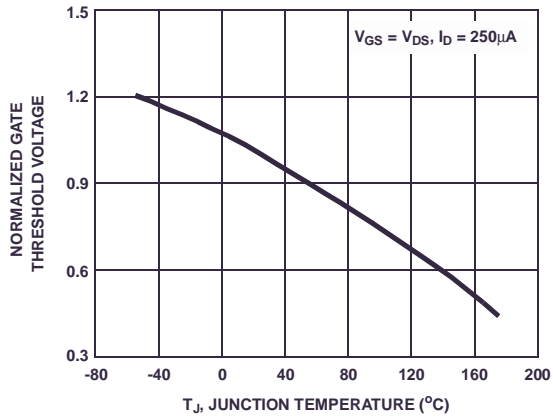


**Figure 9. Drain to Source On Resistance vs Gate Voltage and Drain Current**

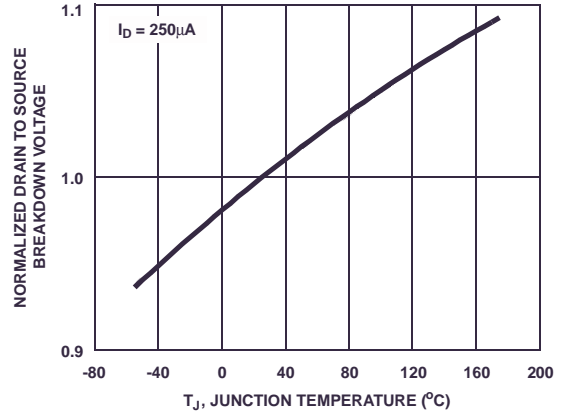


**Figure 10. Normalized Drain to Source On Resistance vs Junction Temperature**

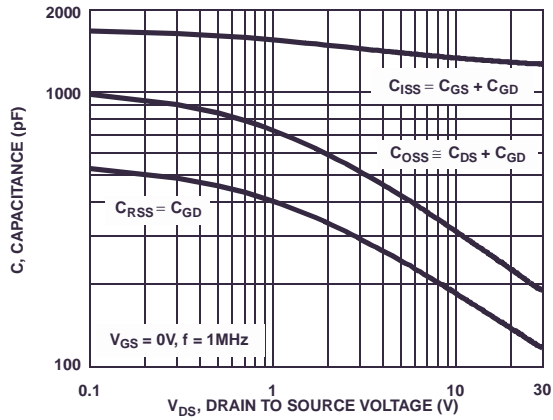
**Typical Characteristics**  $T_C = 25^\circ\text{C}$  unless otherwise noted



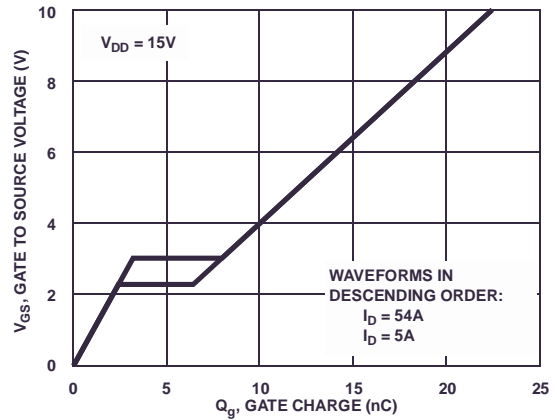
**Figure 11. Normalized Gate Threshold Voltage vs Junction Temperature**



**Figure 12. Normalized Drain to Source Breakdown Voltage vs Junction Temperature**



**Figure 13. Capacitance vs Drain to Source Voltage**



**Figure 14. Gate Charge Waveforms for Constant Gate Current**

Test Circuits and Waveforms

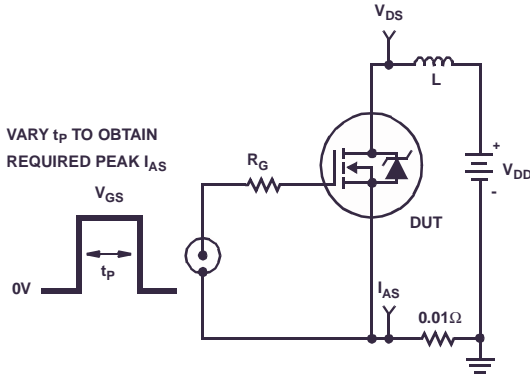


Figure 15. Unclamped Energy Test Circuit

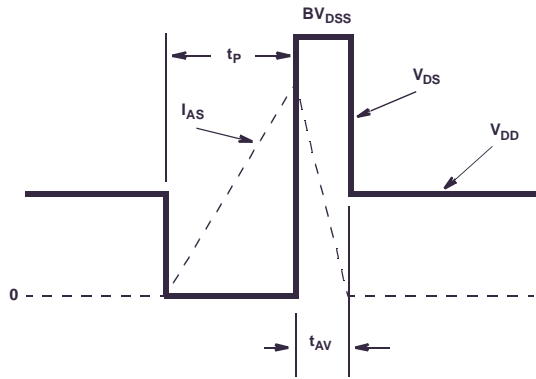


Figure 16. Unclamped Energy Waveforms

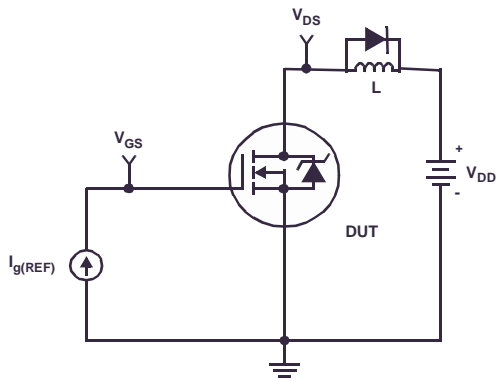


Figure 17. Gate Charge Test Circuit

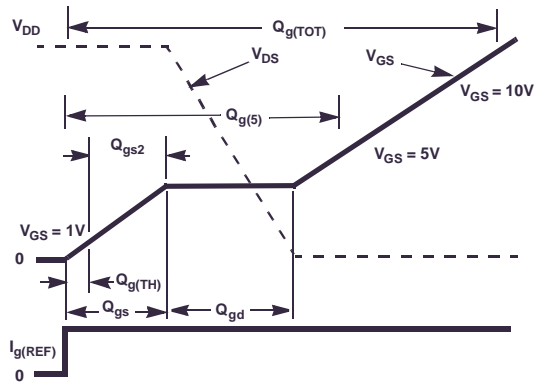


Figure 18. Gate Charge Waveforms

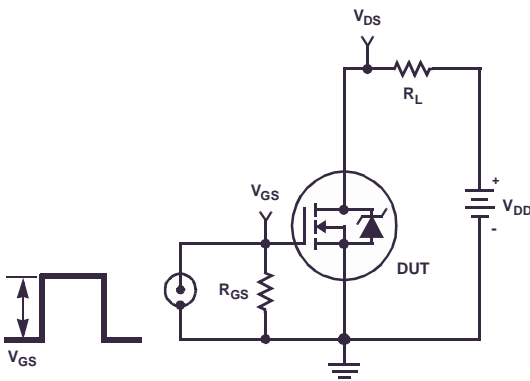


Figure 19. Switching Time Test Circuit

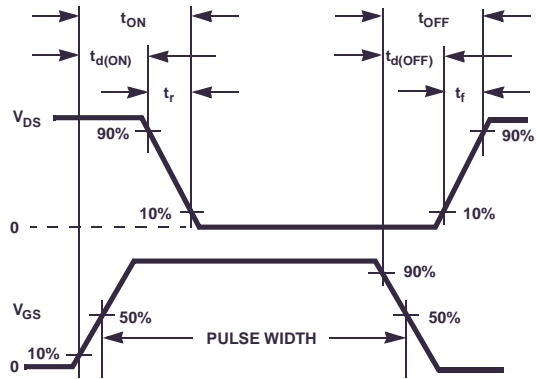


Figure 20. Switching Time Waveforms

### PSPICE Electrical Model

.SUBCKT FDP8880 2 1 3 ; rev October 2004  
 Ca 12 8 9.5e-10  
 Cb 15 14 9.5e-10  
 Cin 6 8 1.15e-9

Dbody 7 5 DbodyMOD  
 Dbreak 5 11 DbreakMOD  
 Dplcap 10 5 DplcapMOD

Ebreak 11 7 17 18 32.88  
 Eds 14 8 5 8 1  
 Egs 13 8 6 8 1  
 Esg 6 10 6 8 1  
 Evthres 6 21 19 8 1  
 Evtemp 20 6 18 22 1

It 8 17 1

Lgate 1 9 5.3e-9  
 Ldrain 2 5 1.0e-9  
 Lsource 3 7 1.7e-9

RLgate 1 9 53  
 RLdrain 2 5 10  
 RLsource 3 7 17

Mmed 16 6 8 8 MmedMOD  
 Mstro 16 6 8 8 MstroMOD  
 Mweak 16 21 8 8 MweakMOD

Rbreak 17 18 RbreakMOD 1  
 Rdrain 50 16 RdrainMOD 1.0e-3  
 Rgate 9 20 2.2  
 RSLC1 5 51 RSLCMOD 1e-6  
 RSLC2 5 50 1e3  
 Rsource 8 7 RsourceMOD 6.8e-3  
 Rvthres 22 8 RvthresMOD 1  
 Rvtemp 18 19 RvtempMOD 1  
 S1a 6 12 13 8 S1AMOD  
 S1b 13 12 13 8 S1BMOD  
 S2a 6 15 14 13 S2AMOD  
 S2b 13 15 14 13 S2BMOD

Vbat 22 19 DC 1

ESLC 51 50 VALUE={{(V(5,51)/ABS(V(5,51)))\*(PWR(V(5,51)/(1e-6\*170),5))}}

.MODEL DbodyMOD D (IS=3E-12 IKF=10 N=1.01 RS=5e-3 TRS1=8e-4 TRS2=2e-7  
 + CJO=4.8e-10 M=0.55 TT=1e-11 XT1=2)

.MODEL DbreakMOD D (RS=0.2 TRS1=1e-3 TRS2=-8.8e-6)

.MODEL DplcapMOD D (CJO=5.5e-10 IS=1e-30 N=10 M=0.45)

.MODEL MstroMOD NMOS (VTO=2.10 KP=170 IS=1e-30 N=10 TOX=1 L=1u W=1u)

.MODEL MmedMOD NMOS (VTO=1.75 KP=10 IS=1e-30 N=10 TOX=1 L=1u W=1u RG=2.2)

.MODEL MweakMOD NMOS (VTO=1.39 KP=0.05 IS=1e-30 N=10 TOX=1 L=1u W=1u RG=22 RS=0.1)

.MODEL RbreakMOD RES (TC1=8.0e-4 TC2=-8e-7)

.MODEL RdrainMOD RES (TC1=-12e-3 TC2=.35e-4)

.MODEL RSLCMOD RES (TC1=9e-4 TC2=1e-6)

.MODEL RsourceMOD RES (TC1=5e-3 TC2=1e-6)

.MODEL RvtempMOD RES (TC1=-2.78e-3 TC2=1.5e-6)

.MODEL RvthresMOD RES (TC1=-1e-3 TC2=-8.2e-6)

.MODEL S1AMOD VSWITCH (RON=1e-5 ROFF=0.1 VON=-4 VOFF=-3.5)

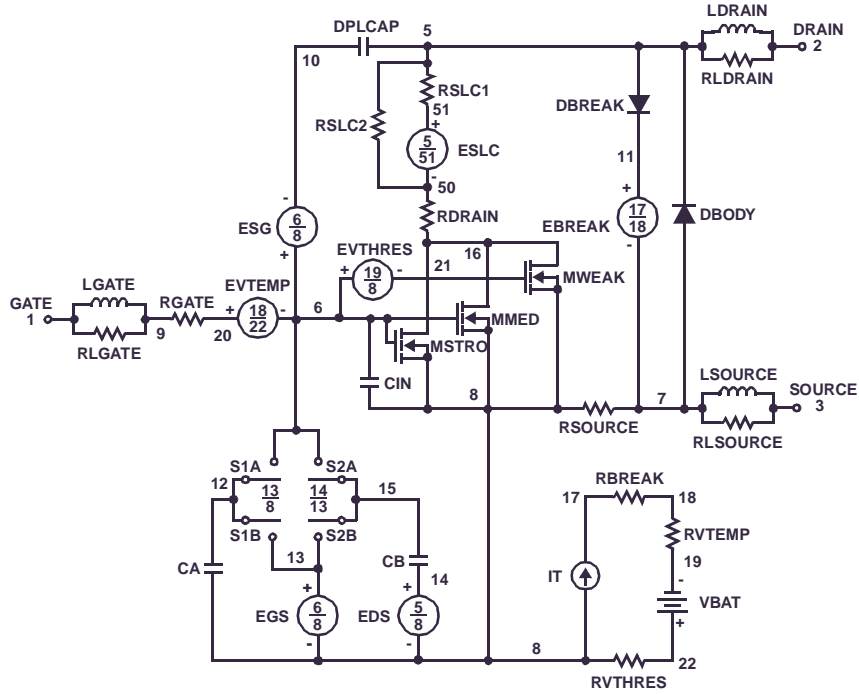
.MODEL S1BMOD VSWITCH (RON=1e-5 ROFF=0.1 VON=-3.5 VOFF=-4)

.MODEL S2AMOD VSWITCH (RON=1e-5 ROFF=0.1 VON=-1.3 VOFF=-0.8)

.MODEL S2BMOD VSWITCH (RON=1e-5 ROFF=0.1 VON=-0.8 VOFF=-1.3)

.ENDS

Note: For further discussion of the PSPICE model, consult **A New PSPICE Sub-Circuit for the Power MOSFET Featuring Global Temperature Options**; IEEE Power Electronics Specialist Conference Records, 1991, written by William J. Hepp and C. Frank Wheatley.



## SABER Electrical Model

rev October 2004

template FDP8880 n2,n1,n3

electrical n2,n1,n3

{

var i iscl

dp..model dbodymod = (isl=3e-12,ikf=10,nl=1.01,rs=5e-3,trs1=8e-4,trs2=2e-7,cjo=4.8e-10,m=0.55,tt=1e-11,xti=2)

dp..model dbreakmod = (rs=0.2,trs1=1e-3,trs2=-8.8e-6)

dp..model dplcapmod = (cjo=5.5e-10,isl=10e-30,nl=10,m=0.45)

m..model mstrongmod = (type=\_n,vto=2.10,kp=170,is=1e-30,tox=1)

m..model mmedmod = (type=\_n,vto=1.75,kp=10,is=1e-30,tox=1)

m..model mweakmod = (type=\_n,vto=1.39,kp=0.05,is=1e-30,tox=1,rs=0.1)

sw\_vcsp..model s1amod = (ron=1e-5,roff=0.1,von=-4,voff=-3.5)

sw\_vcsp..model s1bmod = (ron=1e-5,roff=0.1,von=-3.5,voff=-4)

sw\_vcsp..model s2amod = (ron=1e-5,roff=0.1,von=-1.3,voff=-0.8)

sw\_vcsp..model s2bmod = (ron=1e-5,roff=0.1,von=-0.8,voff=-1.3)

c.ca n12 n8 = 9.5e-10

c.cb n15 n14 = 9.5e-10

c.cin n6 n8 = 1.15e-9

dp.dbody n7 n5 = model=dbodymod

dp.dbreak n5 n11 = model=dbreakmod

dp.dplcap n10 n5 = model=dplcapmod

spe.ebreak n11 n7 n17 n18 = 32.88

spe.eds n14 n8 n5 n8 = 1

spe.egs n13 n8 n6 n8 = 1

spe.esg n6 n10 n6 n8 = 1

spe.evthres n6 n21 n19 n8 = 1

spe.evtemp n20 n6 n18 n22 = 1

i.it n8 n17 = 1

l.lgate n1 n9 = 5.3e-9

l.ldrain n2 n5 = 1.0e-9

l.lsource n3 n7 = 1.7e-9

res.rlgate n1 n9 = 53

res.rldrain n2 n5 = 10

res.rlsource n3 n7 = 17

m.mmed n16 n6 n8 n8 = model=mmedmod, l=1u, w=1u

m.mstrong n16 n6 n8 n8 = model=mstrongmod, l=1u, w=1u

m.mweak n16 n21 n8 n8 = model=mweakmod, l=1u, w=1u

res.rbreak n17 n18 = 1, tc1=8.0e-4,tc2=-8e-7

res.rdrain n50 n16 = 1.0e-3, tc1=-12e-3,tc2=.35e-4

res.rgate n9 n20 = 2.2

res.rslc1 n5 n51 = 1e-6, tc1=9e-4,tc2=1e-6

res.rslc2 n5 n50 = 1e3

res.rsource n8 n7 = 6.8e-3, tc1=5e-3,tc2=1e-6

res.rvthres n22 n8 = 1, tc1=-1e-3,tc2=-8.2e-6

res.rvtemp n18 n19 = 1, tc1=-2.78e-3,tc2=1.5e-6

sw\_vcsp.s1a n6 n12 n13 n8 = model=s1amod

sw\_vcsp.s1b n13 n12 n13 n8 = model=s1bmod

sw\_vcsp.s2a n6 n15 n14 n13 = model=s2amod

sw\_vcsp.s2b n13 n15 n14 n13 = model=s2bmod

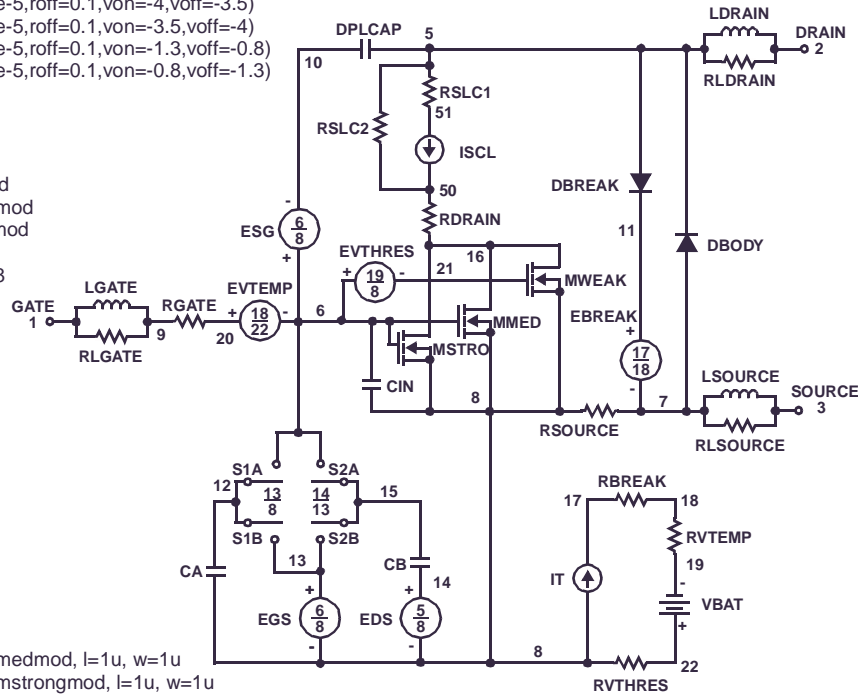
v.vbat n22 n19 = dc=1

equations {

i (n51->n50) +=iscl

iscl: v(n51,n50) = ((v(n5,n51))/(1e-9+abs(v(n5,n51))))\*((abs(v(n5,n51)\*1e6/170)\*\* 5))

}



### PSPICE Thermal Model

REV 23 December 2003

FDP8880T

CTHERM1 TH 6 8e-4  
 CTHERM2 6 5 1e-3  
 CTHERM3 5 4 2.5e-3  
 CTHERM4 4 3 2.6e-3  
 CTHERM5 3 2 8e-3  
 CTHERM6 2 TL 1.5e-2

RTHERM1 TH 6 1.44e-1  
 RTHERM2 6 5 1.9e-1  
 RTHERM3 5 4 3.0e-1  
 RTHERM4 4 3 4.0e-1  
 RTHERM5 3 2 5.7e-1  
 RTHERM6 2 TL 5.8e-1

### SABER Thermal Model

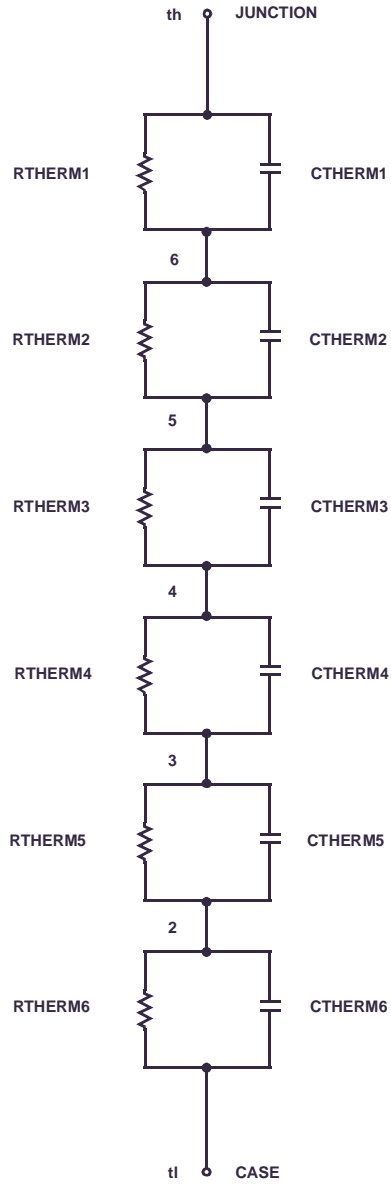
SABER thermal model FDP8880T

template thermal\_model th tl

thermal\_c th, tl

```
{
ctherm.ctherm1 th 6 =8e-4
ctherm.ctherm2 6 5 =1e-3
ctherm.ctherm3 5 4 =2.5e-3
ctherm.ctherm4 4 3 =2.6e-3
ctherm.ctherm5 3 2 =8e-3
ctherm.ctherm6 2 tl =1.5e-2
```

```
rtherm.rtherm1 th 6 =1.44e-1
rtherm.rtherm2 6 5 =1.9e-1
rtherm.rtherm3 5 4 =3.0e-1
rtherm.rtherm4 4 3 =4.0e-1
rtherm.rtherm5 3 2 =5.7e-1
rtherm.rtherm6 2 tl =5.8e-1
}
```



## TRADEMARKS

The following are registered and unregistered trademarks Fairchild Semiconductor owns or is authorized to use and is not intended to be an exhaustive list of all such trademarks.

ACEx™	FACT Quiet Series™	ImpliedDisconnect™	POP™	Stealth™
ActiveArray™	FAST®	IntelliMAX™	Power247™	SuperFET™
Bottomless™	FASTr™	ISOPLANAR™	PowerEdge™	SuperSOT™-3
CoolFET™	FPST™	LittleFET™	PowerSaver™	SuperSOT™-6
CROSSVOLT™	FRFET™	MICROCOUPLER™	PowerTrench®	SuperSOT™-8
DOME™	GlobalOptoisolator™	MicroFET™	QFET®	SyncFET™
EcoSPARK™	GTO™	MicroPak™	QS™	TinyLogic®
E <sup>2</sup> CMOS™	HiSeC™	MICROWIRE™	QT Optoelectronics™	TINYOPTO™
EnSigna™	I <sup>2</sup> C™	MSX™	Quiet Series™	TruTranslation™
FACT™	<i>i-Lo</i> ™	MSXPro™	RapidConfigure™	UHC™
		OCX™	RapidConnect™	UltraFET®
Across the board. Around the world.™		OCXPro™	µSerDes™	UniFET™
The Power Franchise®		OPTOLOGIC®	SILENT SWITCHER®	VCX™
Programmable Active Droop™		OPTOPLANAR™	SMART START™	
		PACMAN™	SPM™	

## DISCLAIMER

FAIRCHILD SEMICONDUCTOR RESERVES THE RIGHT TO MAKE CHANGES WITHOUT FURTHER NOTICE TO ANY PRODUCTS HEREIN TO IMPROVE RELIABILITY, FUNCTION OR DESIGN. FAIRCHILD DOES NOT ASSUME ANY LIABILITY ARISING OUT OF THE APPLICATION OR USE OF ANY PRODUCT OR CIRCUIT DESCRIBED HEREIN; NEITHER DOES IT CONVEY ANY LICENSE UNDER ITS PATENT RIGHTS, NOR THE RIGHTS OF OTHERS.

## LIFE SUPPORT POLICY

FAIRCHILD'S PRODUCTS ARE NOT AUTHORIZED FOR USE AS CRITICAL COMPONENTS IN LIFE SUPPORT DEVICES OR SYSTEMS WITHOUT THE EXPRESS WRITTEN APPROVAL OF FAIRCHILD SEMICONDUCTOR CORPORATION.

As used herein:

- Life support devices or systems are devices or systems which, (a) are intended for surgical implant into the body, or (b) support or sustain life, or (c) whose failure to perform when properly used in accordance with instructions for use provided in the labeling, can be reasonably expected to result in significant injury to the user.
- A critical component is any component of a life support device or system whose failure to perform can be reasonably expected to cause the failure of the life support device or system, or to affect its safety or effectiveness.

## PRODUCT STATUS DEFINITIONS

### Definition of Terms

Datasheet Identification	Product Status	Definition
Advance Information	Formative or In Design	This datasheet contains the design specifications for product development. Specifications may change in any manner without notice.
Preliminary	First Production	This datasheet contains preliminary data, and supplementary data will be published at a later date. Fairchild Semiconductor reserves the right to make changes at any time without notice in order to improve design.
No Identification Needed	Full Production	This datasheet contains final specifications. Fairchild Semiconductor reserves the right to make changes at any time without notice in order to improve design.
Obsolete	Not In Production	This datasheet contains specifications on a product that has been discontinued by Fairchild semiconductor. The datasheet is printed for reference information only.



LittleDiode supplies new, hard to find or obsolete electronic components and semiconductors all over the world.

With over two million different components listed you are sure to find the part you need.

Feel free to visit us today at our online store:

**[LittleDiode.com](http://LittleDiode.com)**

Looking forward to providing you with the best possible service.