

## Low voltage fast-switching PNP power bipolar transistor

### Features

- Very low collector-emitter saturation voltage
- High current gain characteristic
- Fast switching speed
- Surface mounting device in medium power SOT-223 package

### Applications

- Emergency lighting
- LED
- CCFL drivers (back lighting)
- Voltage regulation
- Relay driver

### Description

The device is a PNP transistor manufactured using new "PB-HCD" (Power Bipolar High Current Density) technology. The resulting transistor shows exceptional high gain performances coupled with very low saturation voltage.

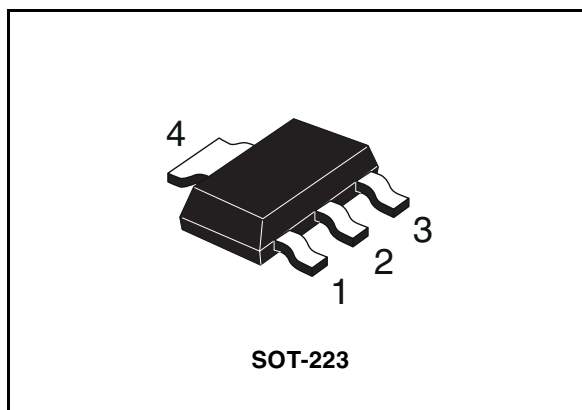

Figure 1. Internal schematic diagram

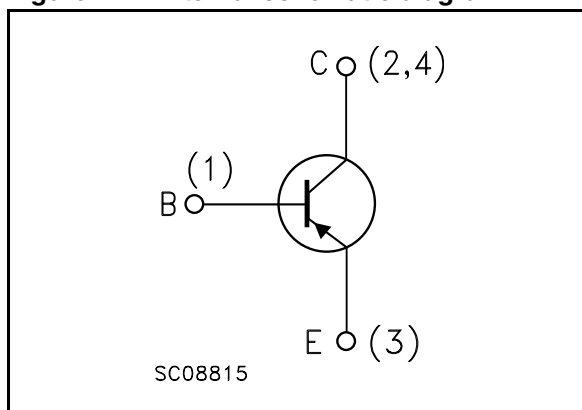

Table 1. Device summary

Order code	Marking	Package	Packaging
2STN2540	N2540	SOT-223	Tape and reel

# 1 Electrical ratings

**Table 2. Absolute maximum rating**

Symbol	Parameter	Value	Unit
$V_{CBO}$	Collector-base voltage ( $I_E = 0$ )	-40	V
$V_{CEO}$	Collector-emitter voltage ( $I_B = 0$ )	-40	V
$V_{EBO}$	Emitter-base voltage ( $I_C = 0$ )	-6	V
$I_C$	Collector current	-5	A
$I_{CM}$	Collector peak current ( $t_P < 5\text{ms}$ )	-10	A
$I_{BM}$	Base peak current ( $t_P < 5\text{ms}$ )	-2	A
$P_{tot}$	Total dissipation at $T_{amb} = 25\text{ °C}$	1.6	W
$T_{stg}$	Storage temperature	-65 to 150	°C
$T_J$	Max. operating junction temperature	150	°C

**Table 3. Thermal data**

Symbol	Parameter	Value	Unit
$R_{thj-amb}^{(1)}$	Thermal resistance junction-amb max	78	°C/W

1. Device mounted on PCB area of  $1\text{cm}^2$

## 2 Electrical characteristics

( $T_{\text{case}} = 25\text{ °C}$  unless otherwise specified)

**Table 4. Electrical characteristics**

Symbol	Parameter	Test conditions	Min.	Typ.	Max.	Unit
$I_{\text{CBO}}$	Collector cut-off current ( $I_{\text{E}} = 0$ )	$V_{\text{CB}} = -30\text{ V}$			-0.1	$\mu\text{A}$
$I_{\text{EBO}}$	Emitter cut-off current ( $I_{\text{C}} = 0$ )	$V_{\text{EB}} = -5\text{ V}$			-0.1	$\mu\text{A}$
$V_{\text{CE(sat)}}^{(1)}$	Collector-emitter saturation voltage	$I_{\text{C}} = -0.5\text{ A}$ $I_{\text{B}} = -5\text{ mA}$		-80	-120	mV
		$I_{\text{C}} = -1\text{ A}$ $I_{\text{B}} = -10\text{ mA}$		-120	-180	mV
		$I_{\text{C}} = -2\text{ A}$ $I_{\text{B}} = -200\text{ mA}$		-140	-200	mV
		$I_{\text{C}} = -5\text{ A}$ $I_{\text{B}} = -500\text{ mA}$		-350	-450	mV
$V_{\text{BE(sat)}}^{(1)}$	Base-emitter saturation voltage	$I_{\text{C}} = -5\text{ A}$ $I_{\text{B}} = -500\text{ mA}$			-1.3	V
$V_{\text{BE(on)}}^{(1)}$	Base-emitter on voltage	$V_{\text{CE}} = -2\text{ V}$ $I_{\text{C}} = -2\text{ A}$			-1.25	V
$h_{\text{FE}}^{(1)}$	DC current gain	$I_{\text{C}} = -0.5\text{ A}$ $V_{\text{CE}} = -2\text{ V}$	250			
		$I_{\text{C}} = -1\text{ A}$ $V_{\text{CE}} = -2\text{ V}$	200			
		$I_{\text{C}} = -2\text{ A}$ $V_{\text{CE}} = -2\text{ V}$	150			
		$I_{\text{C}} = -5\text{ A}$ $V_{\text{CE}} = -2\text{ V}$	50			
$C_{\text{CBO}}$	Collector-base capacitance	$I_{\text{E}} = 0$ $V_{\text{CB}} = -10\text{ V}$ $f = 1\text{ MHz}$		80		pF
$t_{\text{on}}$ $t_{\text{s}}$ $t_{\text{f}}$	Resistive load Turn-on time	$I_{\text{C}} = -1\text{ A}$ $V_{\text{CC}} = -10\text{ V}$ $-I_{\text{B1}} = I_{\text{B2}} = -0.1\text{ A}$		75		ns
	Storage time	$T_{\text{p}} = 30\text{ }\mu\text{s}$		426		ns
	Fall time			62		ns

1. Pulsed duration = 300  $\mu\text{s}$ , duty cycle  $\leq 5\%$

## 2.1 Electrical characteristics (curves)

Figure 2. Output characteristics

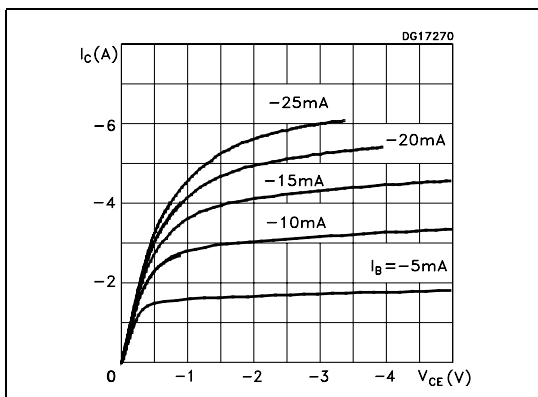

Figure 3. DC current gain

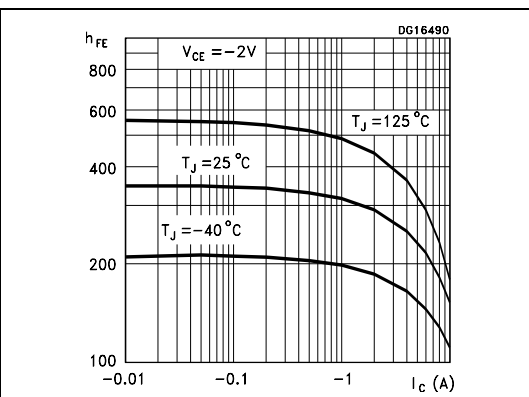

Figure 4. Collector-emitter saturation voltage

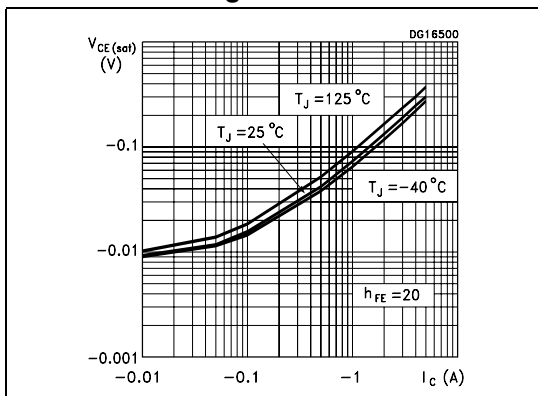

Figure 5. Base-emitter saturation voltage

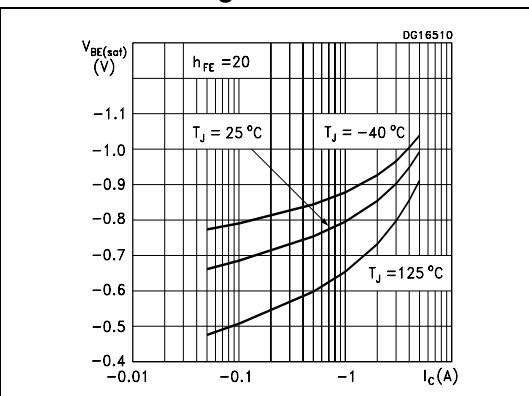

Figure 6. Base-emitter on voltage

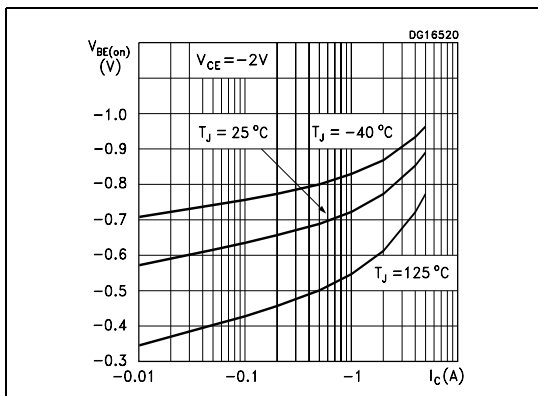

Figure 7. Resistive load switching times

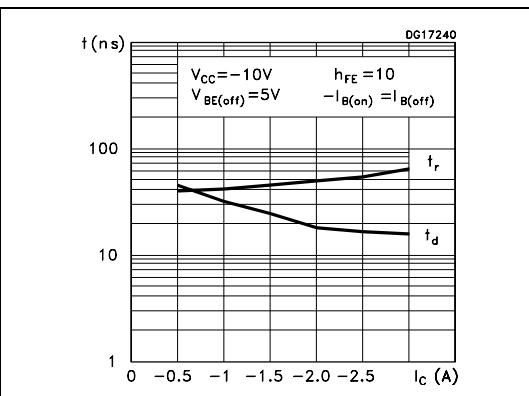

Figure 8. Resistive load switching times

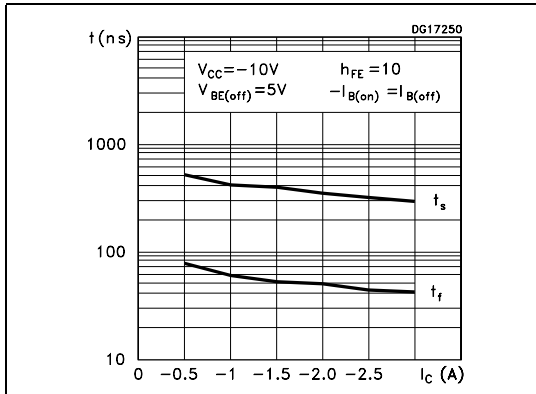
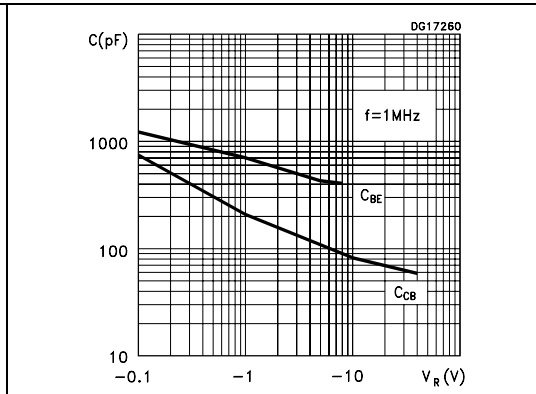
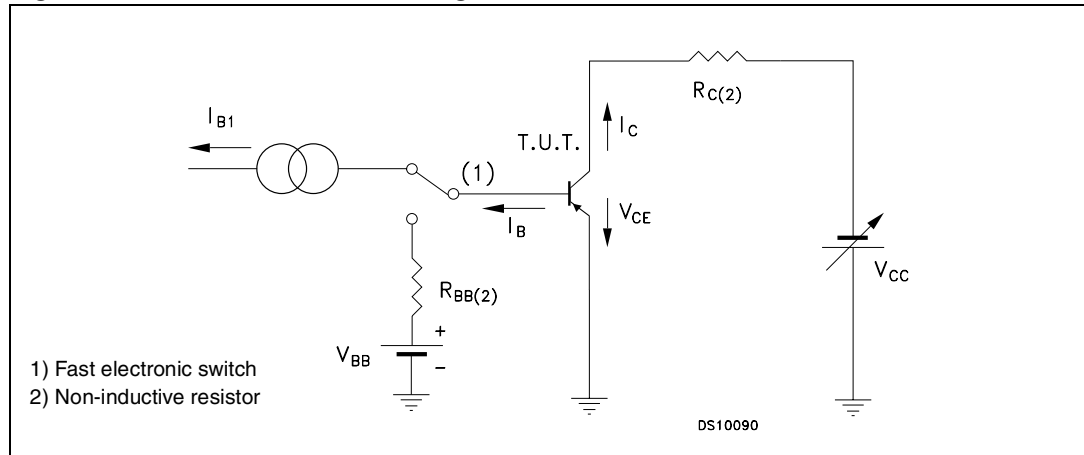

Figure 9. Capacitance



## 2.2 Test circuit

Figure 10. Resistive load switching test circuit



### 3 Package mechanical data

In order to meet environmental requirements, ST offers these devices in ECOPACK® packages. These packages have a Lead-free second level interconnect. The category of second level interconnect is marked on the package and on the inner box label, in compliance with JEDEC Standard JESD97. The maximum ratings related to soldering conditions are also marked on the inner box label. ECOPACK is an ST trademark. ECOPACK specifications are available at: [www.st.com](http://www.st.com)

## SOT-223 mechanical data

DIM.	mm.		
	min.	typ	max.
A			1.80
A1	0.02		0.1
B	0.60	0.70	0.85
B1	2.90	3.00	3.15
c	0.24	0.26	0.35
D	6.30	6.50	6.70
e		2.30	
e1		4.60	
E	3.30	3.50	3.70
H	6.70	7.00	7.30
V			10°

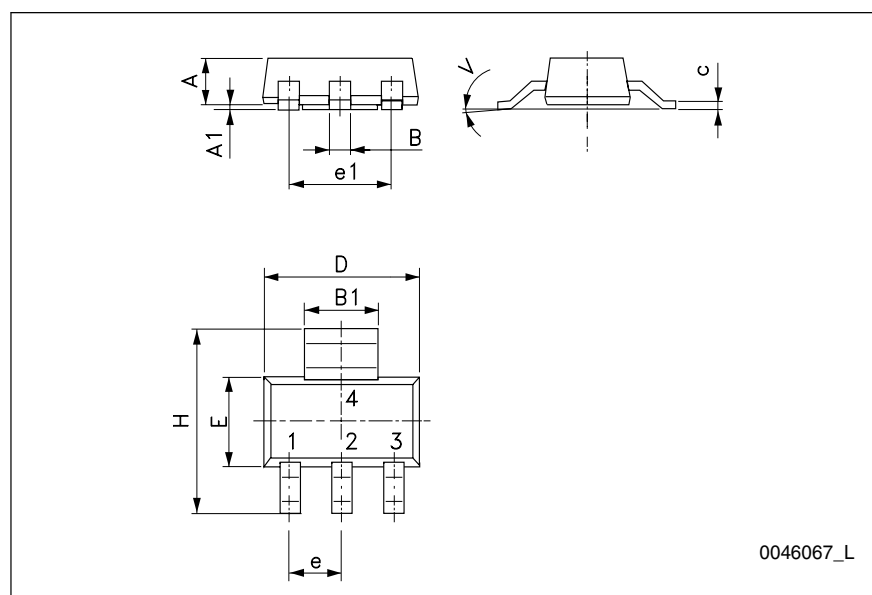

## 4 Revision history

**Table 5. Document revision history**

<b>Date</b>	<b>Revision</b>	<b>Changes</b>
23-Oct-2003	1	Initial release
03-Nov-2006	2	Added new graphics: fig.2, fig. 7, fig.8, fig.9.
14-Jan-2008	3	Document status promoted from preliminary data to datasheet.

**Please Read Carefully:**

Information in this document is provided solely in connection with ST products. STMicroelectronics NV and its subsidiaries ("ST") reserve the right to make changes, corrections, modifications or improvements, to this document, and the products and services described herein at any time, without notice.

All ST products are sold pursuant to ST's terms and conditions of sale.

Purchasers are solely responsible for the choice, selection and use of the ST products and services described herein, and ST assumes no liability whatsoever relating to the choice, selection or use of the ST products and services described herein.

No license, express or implied, by estoppel or otherwise, to any intellectual property rights is granted under this document. If any part of this document refers to any third party products or services it shall not be deemed a license grant by ST for the use of such third party products or services, or any intellectual property contained therein or considered as a warranty covering the use in any manner whatsoever of such third party products or services or any intellectual property contained therein.

**UNLESS OTHERWISE SET FORTH IN ST'S TERMS AND CONDITIONS OF SALE ST DISCLAIMS ANY EXPRESS OR IMPLIED WARRANTY WITH RESPECT TO THE USE AND/OR SALE OF ST PRODUCTS INCLUDING WITHOUT LIMITATION IMPLIED WARRANTIES OF MERCHANTABILITY, FITNESS FOR A PARTICULAR PURPOSE (AND THEIR EQUIVALENTS UNDER THE LAWS OF ANY JURISDICTION), OR INFRINGEMENT OF ANY PATENT, COPYRIGHT OR OTHER INTELLECTUAL PROPERTY RIGHT.**

**UNLESS EXPRESSLY APPROVED IN WRITING BY AN AUTHORIZED REPRESENTATIVE OF ST, ST PRODUCTS ARE NOT RECOMMENDED, AUTHORIZED OR WARRANTED FOR USE IN MILITARY, AIR CRAFT, SPACE, LIFE SAVING, OR LIFE SUSTAINING APPLICATIONS, NOR IN PRODUCTS OR SYSTEMS, WHERE FAILURE OR MALFUNCTION MAY RESULT IN PERSONAL INJURY, DEATH, OR SEVERE PROPERTY OR ENVIRONMENTAL DAMAGE. ST PRODUCTS WHICH ARE NOT SPECIFIED AS "AUTOMOTIVE GRADE" MAY ONLY BE USED IN AUTOMOTIVE APPLICATIONS AT USER'S OWN RISK.**

Resale of ST products with provisions different from the statements and/or technical features set forth in this document shall immediately void any warranty granted by ST for the ST product or service described herein and shall not create or extend in any manner whatsoever, any liability of ST.

ST and the ST logo are trademarks or registered trademarks of ST in various countries.

Information in this document supersedes and replaces all information previously supplied.

The ST logo is a registered trademark of STMicroelectronics. All other names are the property of their respective owners.

© 2008 STMicroelectronics - All rights reserved

STMicroelectronics group of companies

Australia - Belgium - Brazil - Canada - China - Czech Republic - Finland - France - Germany - Hong Kong - India - Israel - Italy - Japan - Malaysia - Malta - Morocco - Singapore - Spain - Sweden - Switzerland - United Kingdom - United States of America

[www.st.com](http://www.st.com)





LittleDiode supplies new, hard to find or obsolete electronic components and semiconductors all over the world.

With over two million different components listed you are sure to find the part you need.

Feel free to visit us today at our online store:

[LittleDiode.com](http://LittleDiode.com)

Looking forward to providing you with the best possible service.