

Hi-Rel PNP bipolar transistor 80 V - 5 A

Datasheet - production data

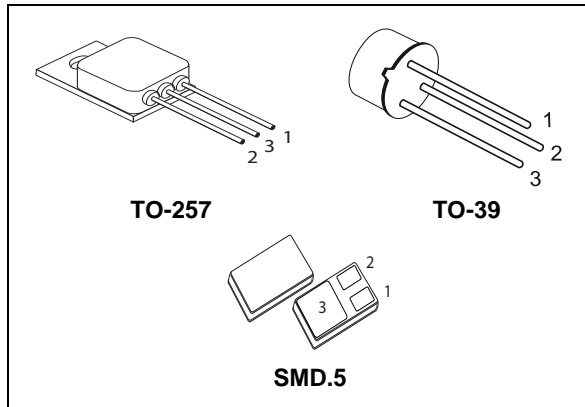
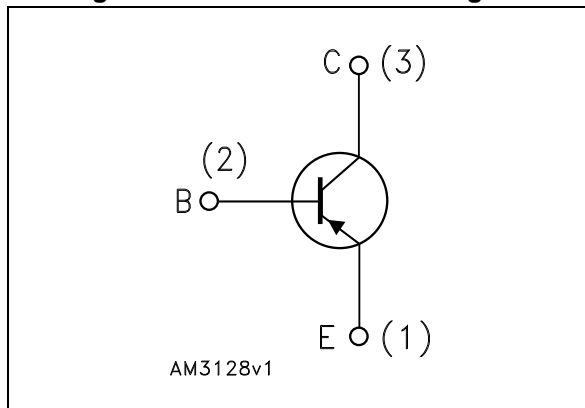

Figure 1. Internal schematic diagram



Features

V_{CE0}	80 V
I_C (max)	5 A
H_{FE} at 10 V - 150 mA	> 70
Operating temperature range	-65°C to +200°C

- Hi-Rel PNP bipolar transistor
- Linear gain characteristics
- ESCC qualified
- European preferred part list - EPPL
- Radiation level: lot specific total dose contact marketing for specified level

Description

The 2N5153HR is a silicon planar epitaxial PNP transistor in TO-39, TO-257 and SMD.5 packages. It is specifically designed for aerospace Hi-Rel applications and ESCC qualified according to the 5204-002 specification. In case of conflict between this datasheet and ESCC detailed specification, the latter prevails.

Table 1. Device summary

Device	Qualification system	Agency specification	Package	Other features	EPPL
2N5153RSHRG	ESCC	5204/002	SMD.5	Emitter on Pin 1 - 100 krad: ESCC LDR	Yes
2N5153SHRG	ESCC	5204/002	SMD.5	Emitter on Pin 1	Yes
2N5153RHRx	ESCC	5204/002	TO-39	100 krad: ESCC LDR	-
2N5153HRx	ESCC	5204/002	TO-39	-	-
2N5153RESYHRx	ESCC	5204/002	TO-257	100 krad : ESCC LDR	-
2N5153ESYHRx	ESCC	5204/002	TO-257	-	-

Contents

1	Electrical ratings	3
2	Electrical characteristics	4
2.1	Electrical characteristics (curves)	5
2.2	Test circuit	6
3	Radiation hardness assurance	7
4	Package mechanical data	9
4.1	TO-257	9
4.2	TO-39	11
4.3	SMD.5	12
5	Order codes	14
6	Shipping details	15
6.1	Date code	15
6.2	Documentation	15
7	Revision history	16

1 Electrical ratings

Table 2. Absolute maximum ratings

Symbol	Parameter	Value	Unit
V_{CBO}	Collector-base voltage ($I_E = 0$)	-100	V
V_{CEO}	Collector-emitter voltage ($I_B = 0$)	-80	V
V_{EBO}	Emitter-base voltage ($I_C = 0$)	-5.5	V
I_C	Collector current	-5	A
P_{TOT}	Total dissipation at $T_{amb} \leq 25\text{ °C}$ for TO-39	1	W
	for TO-257	3.3	W
	$T_C \leq 25\text{ °C}$ for TO-39	10	W
	for TO-257	35	W
	for SMD.5	35	W
T_{STG}	Storage temperature	-65 to 200	°C
T_J	Max. operating junction temperature	200	°C

Table 3. Thermal data for through-hole packages

Symbol	Parameter	TO-39	TO-257	Unit
R_{thJC}	Thermal resistance junction-case max	17.5	5	°C/W
R_{thJA}	Thermal resistance junction-ambient max	175	53	°C/W

Table 4. Thermal data for SMD package

Symbol	Parameter	SMD.5	Unit
R_{thJC}	Thermal resistance junction-case max	5	°C/W

2 Electrical characteristics

$T_{\text{case}} = 25\text{ °C}$ unless otherwise specified

Table 5. Electrical characteristics

Symbol	Parameter	Test conditions	Min.	Typ.	Max.	Unit
I_{CES}	Collector cut-off current ($I_{\text{E}} = 0$)	$V_{\text{CB}} = -60\text{ V}$ $V_{\text{CB}} = -60\text{ V}$ $T_{\text{amb}} = 150\text{ °C}$			-1 -10	μA μA
I_{EBO}	Emitter cut-off current ($I_{\text{C}} = 0$)	$V_{\text{EB}} = -4\text{ V}$ $V_{\text{EB}} = -5.5\text{ V}$			-1 -1	μA mA
I_{CEO}	Collector cut-off current ($I_{\text{B}} = 0$)	$V_{\text{CE}} = -40\text{ V}$			-50	μA
$V_{(\text{BR})\text{CEO}}^{(1)}$	Collector-emitter breakdown voltage ($I_{\text{B}} = 0$)	$I_{\text{C}} = -100\text{ mA}$	-80			V
$V_{\text{CE}(\text{sat})}^{(1)}$	Collector-emitter saturation voltage	$I_{\text{C}} = -5\text{ A}$ $I_{\text{B}} = -0.5\text{ A}$			-1.5	V
$V_{\text{BE}(\text{sat})}^{(1)}$	Base-emitter saturation voltage	$I_{\text{C}} = -2.5\text{ A}$ $I_{\text{B}} = -0.25\text{ A}$ $I_{\text{C}} = -5\text{ A}$ $I_{\text{B}} = -0.5\text{ A}$			-1.45 -2.2	V V
$h_{\text{FE}}^{(1)}$	DC current gain	$I_{\text{C}} = -50\text{ mA}$ $V_{\text{CE}} = -5\text{ V}$ $I_{\text{C}} = -2.5\text{ A}$ $V_{\text{CE}} = -5\text{ V}$ $I_{\text{C}} = -5\text{ A}$ $V_{\text{CE}} = -5\text{ V}$ $I_{\text{C}} = -2.5\text{ A}$ $V_{\text{CE}} = -5\text{ V}$ $T_{\text{amb}} = -55\text{ °C}$	50 70 40 35		200	
h_{fe}	AC forward current transfer ratio	$V_{\text{CE}} = -5\text{ V}$ $I_{\text{C}} = -500\text{ mA}$ $f = 20\text{ MHz}$	3.5			
C_{OBO}	Output capacitance	$I_{\text{E}} = 0$ $V_{\text{CB}} = -10\text{ V}$ $f = 1\text{ MHz}$			250	pF
t_{on}	Turn-on time	$V_{\text{CC}} = -30\text{ V}$ $V_{\text{BB}} = -4\text{ V}$ $V_{\text{in}} \approx -51\text{ V}$ $I_{\text{C}} = 5\text{ A}$ $I_{\text{B1}} = -I_{\text{B2}} = -0.5\text{ A}$			0.5	μs
t_{off}	Turn-off time	$V_{\text{CC}} = -30\text{ V}$ $V_{\text{BB}} = -4\text{ V}$ $V_{\text{in}} \approx -51\text{ V}$ $I_{\text{C}} = -5\text{ A}$ $I_{\text{B1}} = -I_{\text{B2}} = -0.5\text{ A}$			1.3	μs

1. Pulsed duration = 300 μs , duty cycle \leq 1.5%

2.1 Electrical characteristics (curves)

Figure 2. h_{FE} @ $V_{CE} = 5\text{ V}$

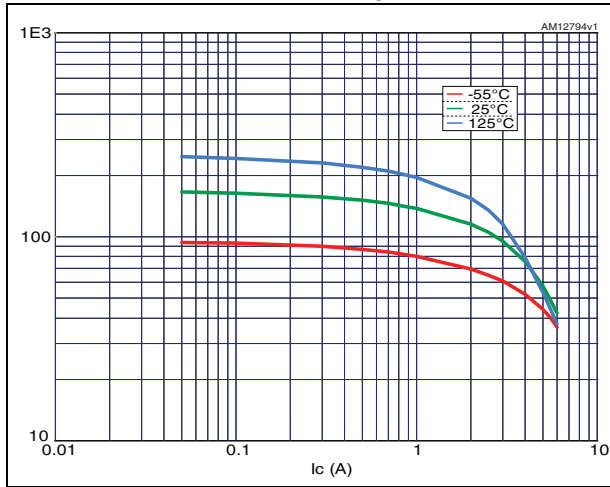

Figure 3. V_{CEsat} @ $h_{FE} = 10$

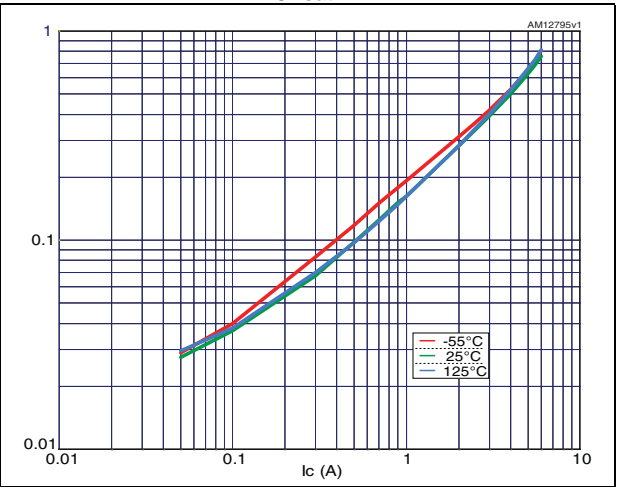

Figure 4. V_{BEsat} @ $h_{FE} = 10$

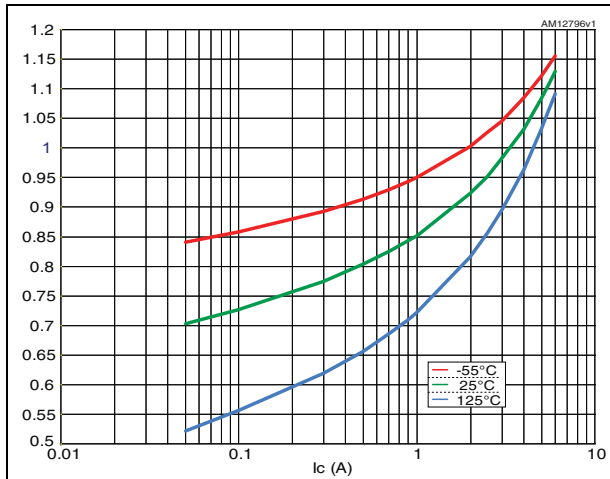
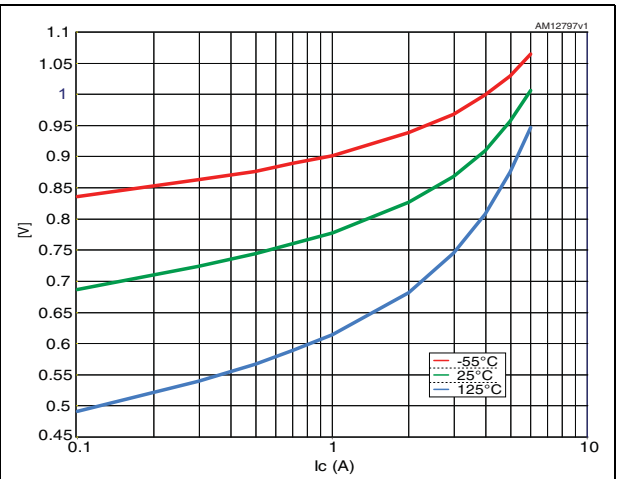
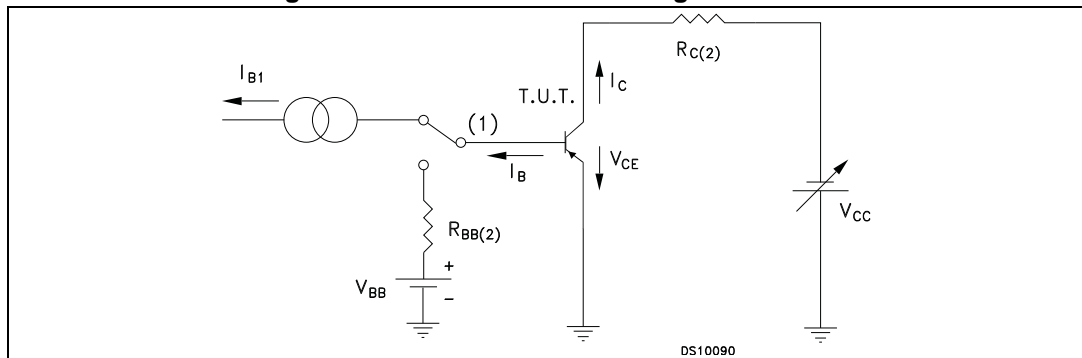

Figure 5. V_{BEON} @ $V_{CE} = 5\text{ V}$



2.2 Test circuit

Figure 6. Resistive load switching test circuit



1. Fast electronic switch
2. Non-inductive resistor

3 Radiation hardness assurance

The products guaranteed in radiation within the ESCC system fully comply with the ESCC 5201/002 and ESCC 22900 specifications.

ESCC radiation assurance

Each product lot is tested according to the ESCC basic specification 22900, with a minimum of 11 samples per diffusion lot and 5 samples per wafer, one sample being kept as unirradiated sample, all of them being fully compliant with the applicable ESCC generic and/or detailed specification.

ST goes beyond the ESCC specification by performing the following procedure:

- Test of 11 pieces by wafer, 5 biased at least 80% of $V_{(BR)CEO}$, 5 unbiased and 1 kept for reference
- Irradiation at 0.1 rad (Si)/s
- Acceptance criteria of each individual wafer if as 100 krad guaranteed if all 10 samples comply with the post radiation electrical characteristics provided in [Table 6](#)
- Delivery together with the parts of the radiation verification test (RVT) report of the particular wafer used to manufacture the products. This RVT includes the value of each parameter at 30, 50, 70 and 100 krad (Si) and after 24 hour annealing at room temperature and after an additional 168 hour annealing at 100°C.

Table 6. ESCC 5201/002 post radiation electrical characteristics

Symbol	Parameter	Test conditions	Min.	Typ.	Max.	Unit
I_{CES}	Collector cut-off current ($I_E = 0$)	$V_{CB} = -60\text{ V}$			-1	μA
I_{EBO}	Emitter cut-off current ($I_C = 0$)	$V_{EB} = -4\text{ V}$ $V_{EB} = -5.5\text{ V}$			-1 -1	μA mA
I_{CEO}	Collector cut-off current ($I_B = 0$)	$V_{CE} = -40\text{ V}$			-50	μA
$V_{(BR)CEO}^{(1)}$	Collector-emitter breakdown voltage ($I_B = 0$)	$I_C = -100\text{ mA}$	-80			V
$V_{CE(sat)}^{(1)}$	Collector-emitter saturation voltage	$I_C = -5\text{ A}$ $I_B = -0.5\text{ A}$			-1.5	V
$V_{BE(sat)}^{(1)}$	Base-emitter saturation voltage	$I_C = -2.5\text{ A}$ $I_B = -0.25\text{ A}$ $I_C = -5\text{ A}$ $I_B = -0.5\text{ A}$			-1.45 -2.2	V V
$[h_{FE}]^{(1)}$	Post irradiation gain calculation ⁽²⁾	$I_C = -50\text{ mA}$ $V_{CE} = -5\text{ V}$ $I_C = -2.5\text{ A}$ $V_{CE} = -5\text{ V}$ $I_C = -5\text{ A}$ $V_{CE} = -5\text{ V}$	[25] [35] [20]		200	

1. Pulsed duration = 300 μs , duty cycle $\leq 1.5\%$
2. The post-irradiation gain calculation of $[h_{FE}]$, made using h_{FE} measurements from prior to and on completion of irradiation testing and after each annealing step if any, shall be as specified in MILSTD-750 method 1019

4 Package mechanical data

In order to meet environmental requirements, ST offers these devices in different grades of ECOPACK® packages, depending on their level of environmental compliance. ECOPACK® specifications, grade definitions and product status are available at: www.st.com. ECOPACK® is an ST trademark.

4.1 TO-257

Figure 7. TO-257 mechanical drawing

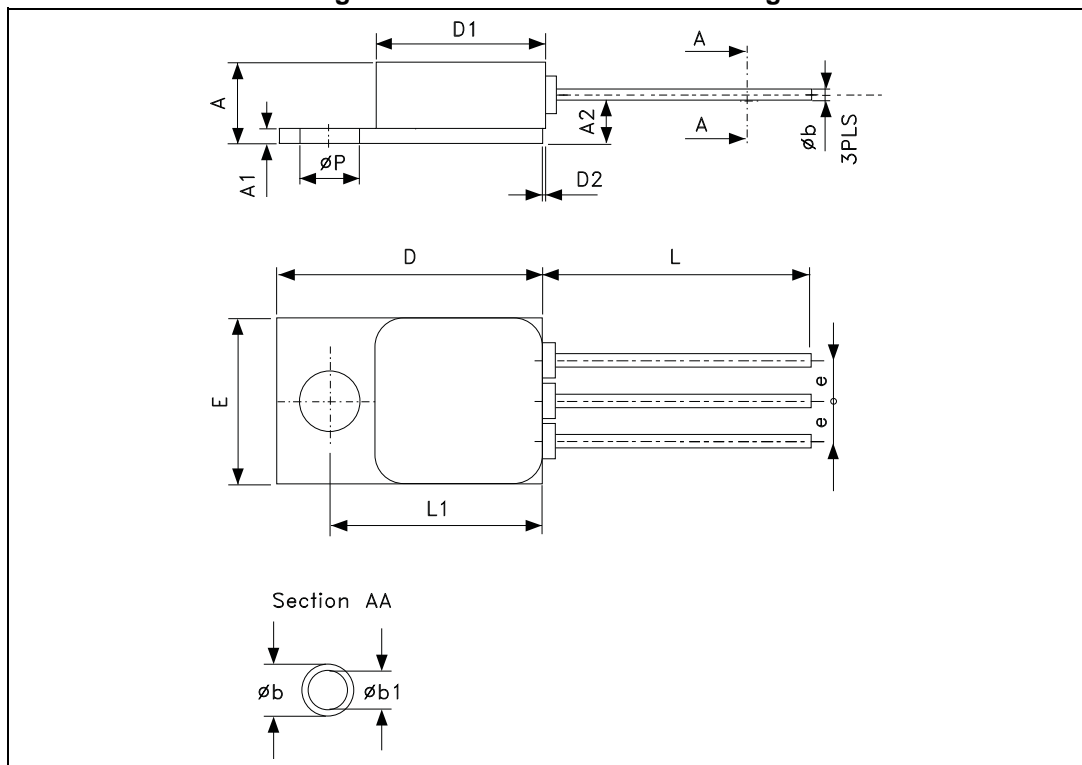

Figure 8. TO-257 mechanical data

Dim.	mm		
	Min.	Typ.	Max.
A	4.83		5.08
A1	0.89		1.14
A2		3.05	
b	0.64		1.02
b1	0.64	0.76	0.89
D	16.38		16.89
D1	10.41		10.92
D2			0.97
e		2.54	
E	10.41		10.67
L	12.70		19.05
L1	13.39		13.64
P	3.56		3.81

4.2 TO-39

Figure 9. TO-39 drawing

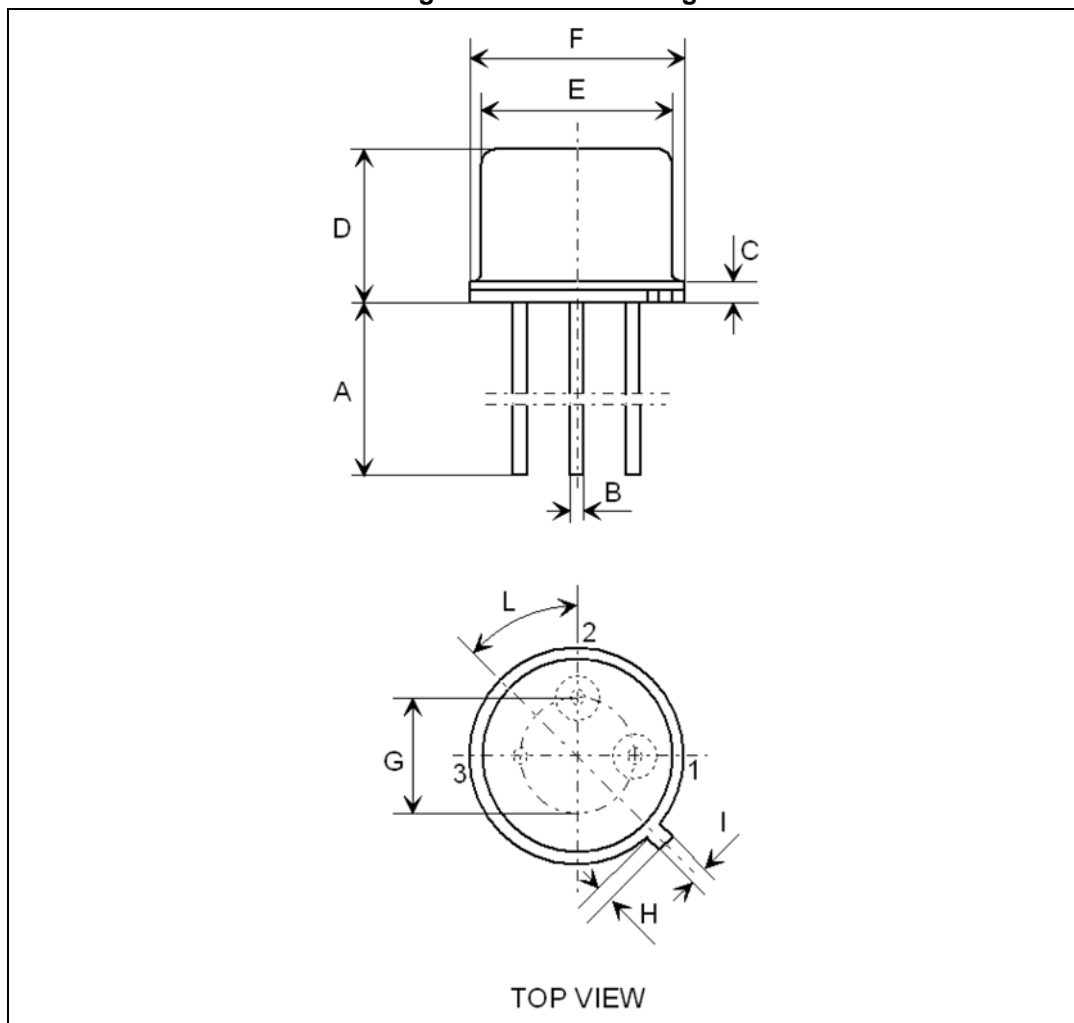

Table 7. TO-39 mechanical data

Dim.	mm		
	Min.	Typ.	Max.
A	-	12.70	14.20
B		0.40	0.49
C		0.58	0.74
D		6.00	6.40
E		8.15	8.25
F		9.10	9.20
G		4.93	5.23
H		0.85	0.95
I		0.75	0.85
L		42°	48°

4.3 SMD.5

Figure 10. TSMD.5 drawing

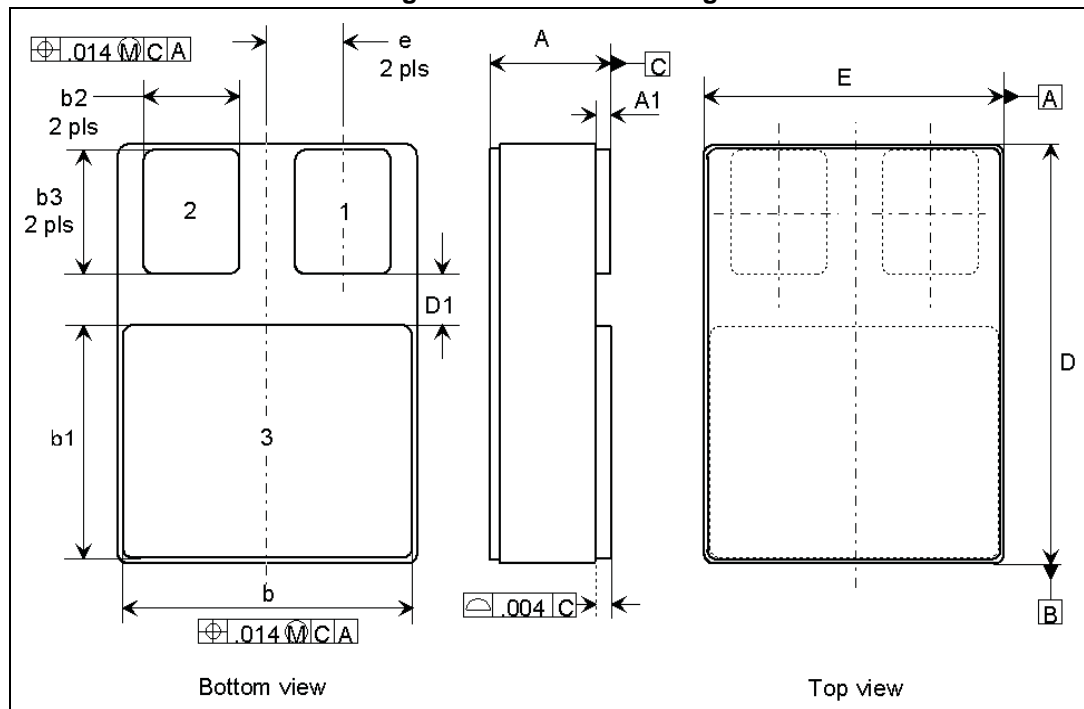

Table 8. SMD.5 mechanical data

Dim.	mm			Inch		
	Min.	Typ.	Max.	Min.	Typ.	Max.
A	2.84	3.00	3.15	0.112	0.118	0.124
A1	0.25	0.38	0.51	0.010	0.015	0.020
b	7.13	7.26	7.39	0.281	0.286	0.291
b1	5.58	5.72	5.84	0.220	0.225	0.230
b2	2.28	2.41	2.54	0.090	0.095	0.100
	2.92	3.05	3.18	0.115	0.120	0.125
D	10.03	10.16	10.28	0.935	0.400	0.405
D1	0.76			0.030		0.685
E	7.39	7.52	7.64	0.291	0.296	0.301
e		1.91			0.075	

5 Order codes

Table 9. Order codes

CPN	Agency specification	EPPL	Quality level	Other features	Package	Lead finish	Marking ⁽¹⁾	Packing
2N5153S1	-	-	Engineering model ESCC	Emitter on Pin 1	SMD.5	Gold	2N5153S1	Strip Pack
2N5153ESY1	-	-	Engineering model ESCC	-	TO-257	Gold	2N5153ESY1 + BeO	Strip Pack
2N5153RSHRG	5204/002/06R	Yes	ESCC	Emitter on Pin 1 - 100 krad : ESCC LDR	SMD.5	Gold	520400206R	Strip Pack
2N5153SHRG	5204/002/06	Yes	ESCC	Emitter on Pin 1	SMD.5	Gold	520400206	Strip Pack
2N5153RHRG	5204/002/01R	-	ESCC	100 krad : ESCC LDR	TO-39	Gold	520400201R	Strip Pack
2N5153RHRT	5204/002/02R	-	ESCC	100 krad : ESCC LDR	TO-39	Solder Dip	520400202R	Strip Pack
2N5153HRG	5204/002/01	-	ESCC	-	TO-39	Gold	520400201	Strip Pack
2N5153HRT	5204/002/02	-	ESCC	-	TO-39	Solder Dip	520400202	Strip Pack
2N5153RESYHRG	5204/002/04R	-	ESCC	100 krad : ESCC LDR	TO-257	Gold	520400204R + BeO	Strip Pack
2N5153RESYHRT	5204/002/05R	-	ESCC	100 krad : ESCC LDR	TO-257	Solder Dip	520400205R + BeO	Strip Pack
2N5153ESYHRG	5204/002/04	-	ESCC	-	TO-257	Gold	520400204 + BeO	Strip Pack
2N5153ESYHRT	5204/002/05	-	ESCC	-	TO-257	Solder Dip	520400205 + BeO	Strip Pack

1. Specific marking only. The full marking includes in addition: For the Engineering Models: ST logo, date code; country of origin (FR). For ESCC flight parts: ST logo, date code, country of origin (FR), ESA logo, serial number of the part within the assembly lot.

Contact ST sales office for information about the specific conditions for:

- Products in die form
- Tape and reel packing

6 Shipping details

6.1 Date code

Date code xyywwz is structured as below table:

Table 10. Date code

	x	yy	ww	z
EM (ESCC)	3	last two digits of the year	week digits	lot index in the week
ESCC FLIGHT	-			

6.2 Documentation

Table 11. Documentation provided for each type of product

Quality level	Radiation level	Documentation
Engineering model	-	-
ESCC Flight	-	Certificate of conformance
	100 krad	Certificate of conformance
		0.1 rad/s radiation verification test report

7 Revision history

Table 12. Document revision history

Date	Revision	Changes
10-Dec-2008	1	Initial release
08-Jan-2010	2	Modified Table 1: Device summary
12-Sep-2012	3	Added: Section 2.1: Electrical characteristics (curves) on page 5
12-Dec-2013	4	Updated Table 1: Device summary and Section 4: Package mechanical data . Added Section 3: Radiation hardness assurance , Section 5: Order codes and Section 6: Shipping details .
28-Mar-2014	5	Updated Table 1: Device summary and Table 9: Order codes . Minor text changes.

Please Read Carefully:

Information in this document is provided solely in connection with ST products. STMicroelectronics NV and its subsidiaries ("ST") reserve the right to make changes, corrections, modifications or improvements, to this document, and the products and services described herein at any time, without notice.

All ST products are sold pursuant to ST's terms and conditions of sale.

Purchasers are solely responsible for the choice, selection and use of the ST products and services described herein, and ST assumes no liability whatsoever relating to the choice, selection or use of the ST products and services described herein.

No license, express or implied, by estoppel or otherwise, to any intellectual property rights is granted under this document. If any part of this document refers to any third party products or services it shall not be deemed a license grant by ST for the use of such third party products or services, or any intellectual property contained therein or considered as a warranty covering the use in any manner whatsoever of such third party products or services or any intellectual property contained therein.

UNLESS OTHERWISE SET FORTH IN ST'S TERMS AND CONDITIONS OF SALE ST DISCLAIMS ANY EXPRESS OR IMPLIED WARRANTY WITH RESPECT TO THE USE AND/OR SALE OF ST PRODUCTS INCLUDING WITHOUT LIMITATION IMPLIED WARRANTIES OF MERCHANTABILITY, FITNESS FOR A PARTICULAR PURPOSE (AND THEIR EQUIVALENTS UNDER THE LAWS OF ANY JURISDICTION), OR INFRINGEMENT OF ANY PATENT, COPYRIGHT OR OTHER INTELLECTUAL PROPERTY RIGHT.

ST PRODUCTS ARE NOT DESIGNED OR AUTHORIZED FOR USE IN: (A) SAFETY CRITICAL APPLICATIONS SUCH AS LIFE SUPPORTING, ACTIVE IMPLANTED DEVICES OR SYSTEMS WITH PRODUCT FUNCTIONAL SAFETY REQUIREMENTS; (B) AERONAUTIC APPLICATIONS; (C) AUTOMOTIVE APPLICATIONS OR ENVIRONMENTS, AND/OR (D) AEROSPACE APPLICATIONS OR ENVIRONMENTS. WHERE ST PRODUCTS ARE NOT DESIGNED FOR SUCH USE, THE PURCHASER SHALL USE PRODUCTS AT PURCHASER'S SOLE RISK, EVEN IF ST HAS BEEN INFORMED IN WRITING OF SUCH USAGE, UNLESS A PRODUCT IS EXPRESSLY DESIGNATED BY ST AS BEING INTENDED FOR "AUTOMOTIVE, AUTOMOTIVE SAFETY OR MEDICAL" INDUSTRY DOMAINS ACCORDING TO ST PRODUCT DESIGN SPECIFICATIONS. PRODUCTS FORMALLY ESCC, QML OR JAN QUALIFIED ARE DEEMED SUITABLE FOR USE IN AEROSPACE BY THE CORRESPONDING GOVERNMENTAL AGENCY.

Resale of ST products with provisions different from the statements and/or technical features set forth in this document shall immediately void any warranty granted by ST for the ST product or service described herein and shall not create or extend in any manner whatsoever, any liability of ST.

ST and the ST logo are trademarks or registered trademarks of ST in various countries.

Information in this document supersedes and replaces all information previously supplied.

The ST logo is a registered trademark of STMicroelectronics. All other names are the property of their respective owners.

© 2014 STMicroelectronics - All rights reserved

STMicroelectronics group of companies

Australia - Belgium - Brazil - Canada - China - Czech Republic - Finland - France - Germany - Hong Kong - India - Israel - Italy - Japan - Malaysia - Malta - Morocco - Philippines - Singapore - Spain - Sweden - Switzerland - United Kingdom - United States of America

www.st.com





LittleDiode supplies new, hard to find or obsolete electronic components and semiconductors all over the world.

With over two million different components listed you are sure to find the part you need.

Feel free to visit us today at our online store:

LittleDiode.com

Looking forward to providing you with the best possible service.