



# ESDA25B1

Application Specific Discretes  
A.S.D.<sup>TM</sup>

TRANSIL<sup>TM</sup> ARRAY  
FOR ESD PROTECTION

## APPLICATIONS

Where transient overvoltage protection in ESD sensitive equipment is required, such as :

- COMPUTER
- PRINTERS
- COMMUNICATION SYSTEMS

It is particularly recommended for RS232 I/O port protection where the line interface withstands only 2 kV ESD surges.

## FEATURES

- 6 BIDIRECTIONAL TRANSIL<sup>TM</sup> FUNCTIONS
- VERY LOW CAPACITANCE :  $C = 20 \text{ pF} @ V_{RM}$
- 150 W peak pulse power (8/20  $\mu\text{s}$ )

## DESCRIPTION

The ESDA25B1 is a monolithic voltage suppressor designed to protect components which are connected to data and transmission lines against EDS.

## BENEFITS

High ESD protection level : up to 25 kV  
High integration  
Suitable for high density boards

## COMPLIES WITH THE FOLLOWING STANDARDS :

IEC 1000-4-2 : level 4

MIL STD 883C-Method 3015-6 : class 3  
(human body model)

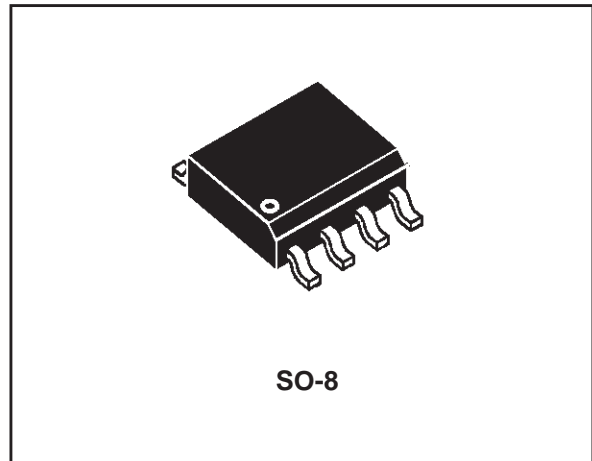

## FUNCTIONAL DIAGRAM

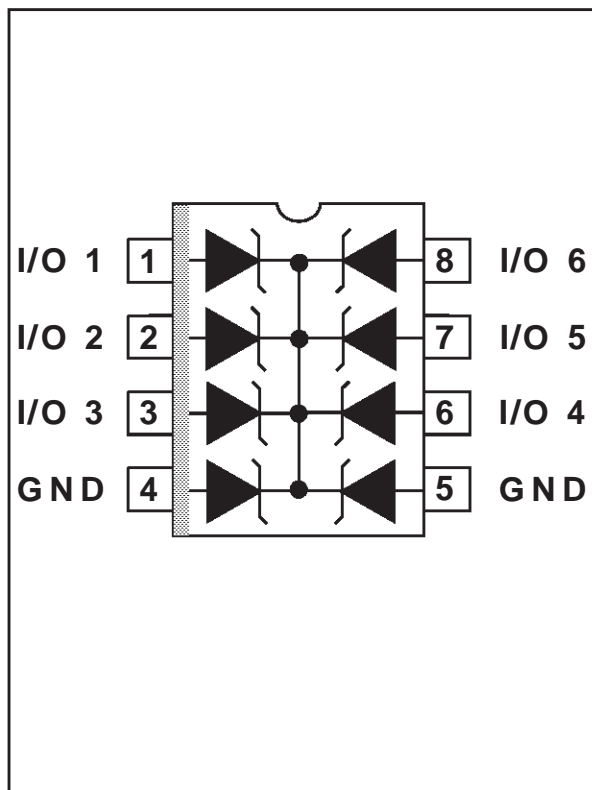

## ESDA25B1

### ABSOLUTE MAXIMUM RATINGS ( $T_{amb} = 25^{\circ}\text{C}$ )

Symbol	Parameter	Value	Unit
$V_{PP}$	Electrostatic discharge MIL STD 883C - Method 3015-6	25	kV
$P_{PP}$	Peak pulse power (8/20 $\mu\text{s}$ )	150	W
$T_{stg}$ $T_j$	Storage temperature range Maximum junction temperature	- 55 to + 150 125	$^{\circ}\text{C}$ $^{\circ}\text{C}$
$T_L$	Maximum lead temperature for soldering during 10s	260	$^{\circ}\text{C}$

### ELECTRICAL CHARACTERISTICS ( $T_{amb} = 25^{\circ}\text{C}$ )

Symbol	Parameter
$V_{RM}$	Stand-off voltage
$V_{BR}$	Breakdown voltage
$V_{CL}$	Clamping voltage
$I_{RM}$	Leakage current
$I_{PP}$	Peak pulse current
$\alpha T$	Voltage temperature coefficient
C	Capacitance
$R_d$	Dynamic resistance

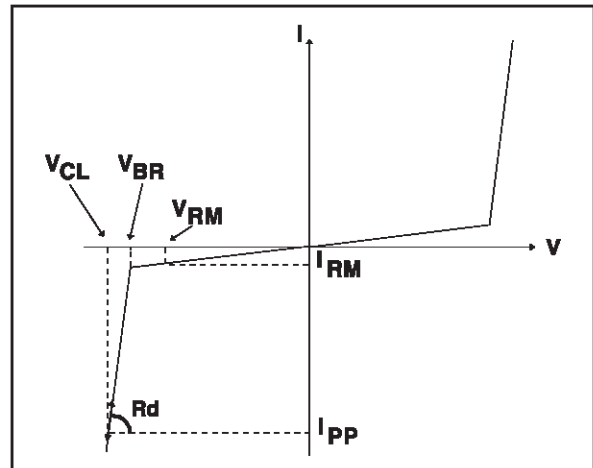

Types	$V_{BR}$ @		$I_r$	$I_{RM}$ @ $V_{RM}$		$R_d$ typ. note 2	$\alpha T$ max. note 3	C typ. 0V bias
	min.	max.		max.				
	note 1			note 1				
	V	V	mA	$\mu\text{A}$	V	$\Omega$	$10^{-4}/^{\circ}\text{C}$	pF
ESDA25B1	25	30	1	2	24	1.5	9.7	15

note 1 : Between any I/O pin and Ground

note 2 : Square pulse,  $I_{pp} = 25\text{A}$ ,  $t_p = 2.5\mu\text{s}$ .

note 3 :  $\Delta V_{BR} = \alpha T * (T_{amb} - 25^{\circ}\text{C}) * V_{BR}(25^{\circ}\text{C})$

## CALCULATION OF THE CLAMPING VOLTAGE

### USE OF THE DYNAMIC RESISTANCE

The ESDA family has been designed to clamp fast spikes like ESD. Generally the PCB designers need to calculate easily the clamping voltage  $V_{CL}$ . This is why we give the dynamic resistance in addition to the classical parameters. The voltage across the protection cell can be calculated with the following formula:

$$V_{CL} = V_{BR} + R_d I_{PP}$$

Where  $I_{PP}$  is the peak current through the ESDA cell.

### DYNAMIC RESISTANCE MEASUREMENT

The short duration of the ESD has led us to prefer a more adapted test wave, as below defined, to the classical 8/20 $\mu$ s and 10/1000 $\mu$ s surges.

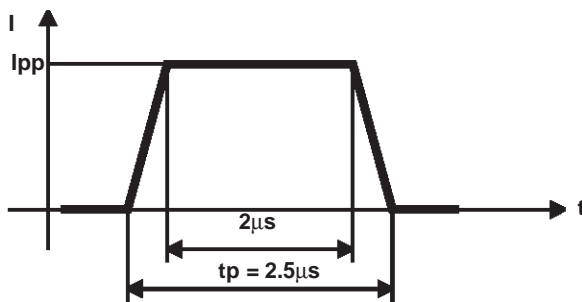

2.5 $\mu$ s duration measurement wave.

As the value of the dynamic resistance remains stable for a surge duration lower than 20 $\mu$ s, the 2.5 $\mu$ s rectangular surge is well adapted. In addition both rise and fall times are optimized to avoid any parasitic phenomenon during the measurement of  $R_d$ .

# ESDA25B1

**Fig. 1 :** Peak power dissipation versus initial junction temperature.

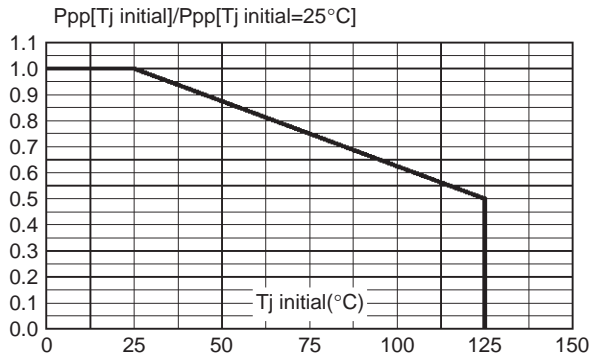

**Fig. 2 :** Peak pulse power versus exponential pulse duration ( $T_j \text{ initial} = 25^\circ\text{C}$ ).

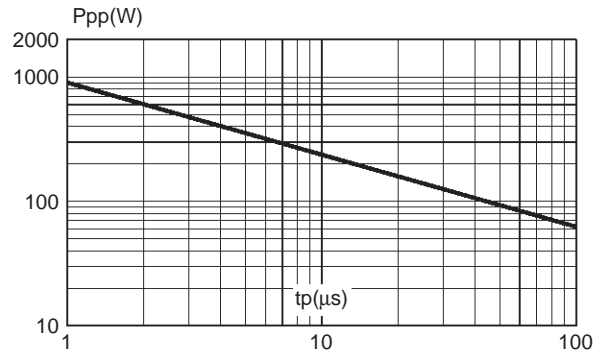

**Fig. 3 :** Clamping voltage versus peak pulse current ( $T_j \text{ initial} = 25^\circ\text{C}$ ).  
Rectangular waveform  $t_p = 2.5 \mu\text{s}$ .

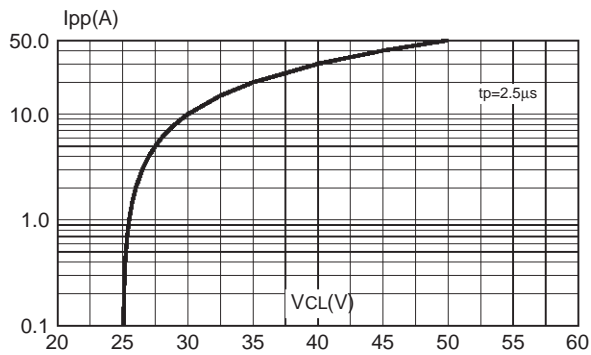

**Fig. 4 :** Capacitance versus reverse applied voltage (typical values).

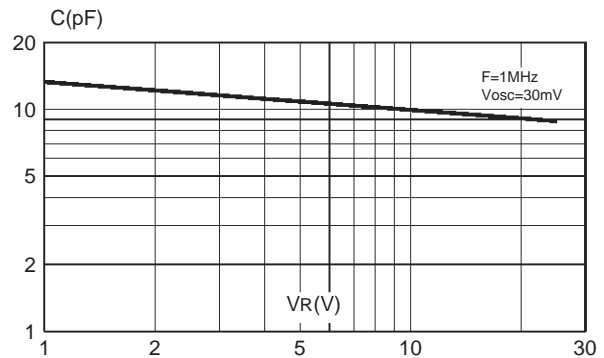

**Fig. 5 :** Relative variation of leakage current versus junction temperature (typical values).

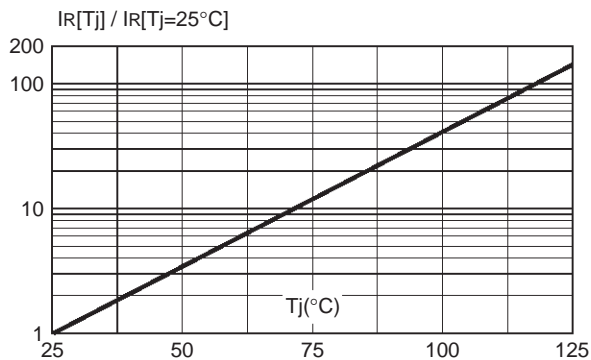

ORDER CODE

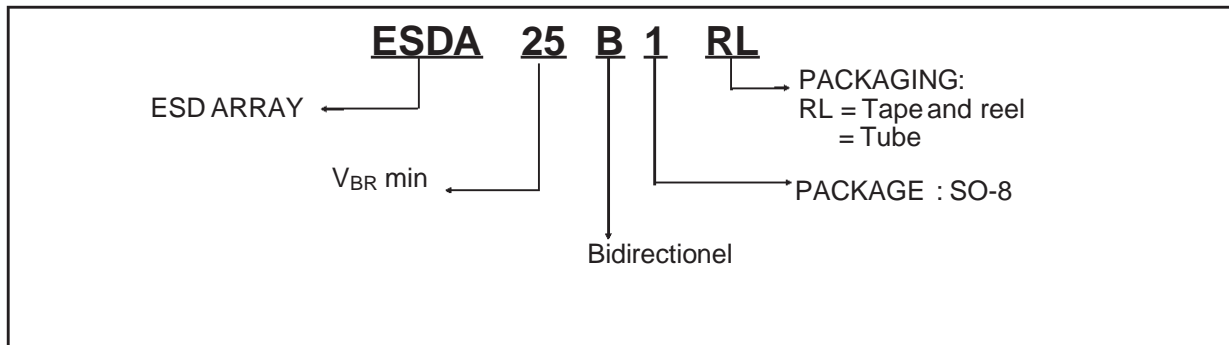

MARKING : Logo, Date Code, E25B1

PACKAGE MECHANICAL DATA

SO-8 Plastic

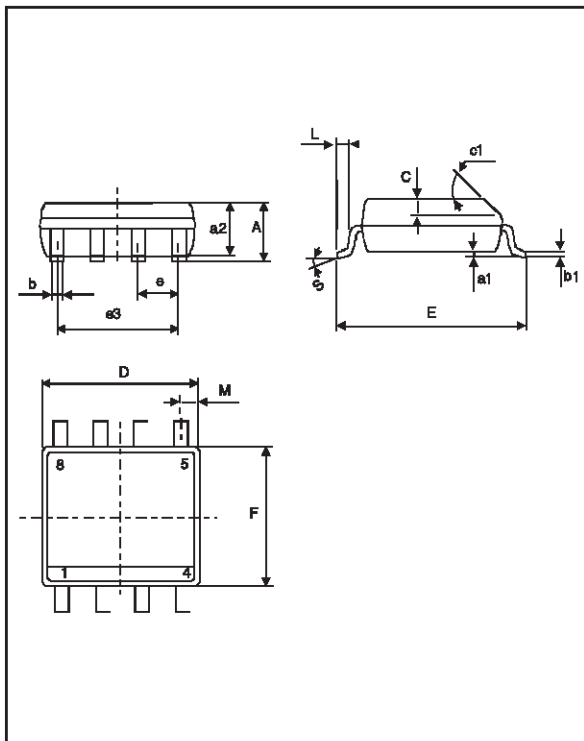

REF.	DIMENSIONS					
	Millimeters			Inches		
	Min.	Typ.	Max.	Min.	Typ.	Max.
A			1.75			0.069
a1	0.1		0.25	0.004		0.010
a2			1.65			0.065
a3	0.65		0.85	0.026		0.033
b	0.35		0.48	0.014		0.019
b1	0.19		0.25	0.007		0.010
C	0.25		0.5	0.010		0.020
c1	45° (typ)					
D	4.8		5.0	0.189		0.197
E	5.8		6.2	0.228		0.244
e		1.27			0.050	
e3		3.81			0.150	
F	3.8		4.0	0.15		0.157
L	0.4		1.27	0.016		0.050
M			0.6			0.024
S	8° (max)					

Packaging : Preferred packaging is tape and reel.

Weight : 0.08g.

Information furnished is believed to be accurate and reliable. However, STMicroelectronics assumes no responsibility for the consequences of use of such information nor for any infringement of patents or other rights of third parties which may result from its use. No license is granted by implication or otherwise under any patent or patent rights of STMicroelectronics. Specifications mentioned in this publication are subject to change without notice. This publication supersedes and replaces all information previously supplied. STMicroelectronics products are not authorized for use as critical components in life support devices or systems without express written approval of STMicroelectronics.

The ST logo is a registered trademark of STMicroelectronics

© 1999 STMicroelectronics - Printed in Italy - All rights reserved.

STMicroelectronics GROUP OF COMPANIES

Australia - Brazil - China - Finland - France - Germany - Hong Kong - India - Italy - Japan - Malaysia  
Malta - Morocco - Singapore - Spain - Sweden - Switzerland - United Kingdom - U.S.A.

<http://www.st.com>





LittleDiode supplies new, hard to find or obsolete electronic components and semiconductors all over the world.

With over two million different components listed you are sure to find the part you need.

Feel free to visit us today at our online store:

[LittleDiode.com](http://LittleDiode.com)

Looking forward to providing you with the best possible service.