

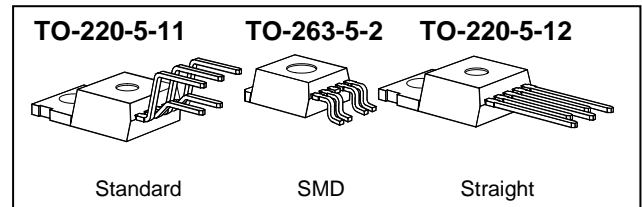
# Smart Highside Power Switch

## One Channel: 20mΩ

### Product Summary

On-state Resistance	RON	20mΩ
Operating Voltage	V <sub>bb(on)</sub>	4.75 ... 41V
Nominal load current	I <sub>L(ISO)</sub>	21A
Current limitation	I <sub>L(lim)</sub>	65A

### Package



### General Description

- N channel vertical power FET with charge pump, ground referenced CMOS compatible input, monolithically integrated in Smart SIPMOS® technology.
- Providing embedded protective functions.

### Application

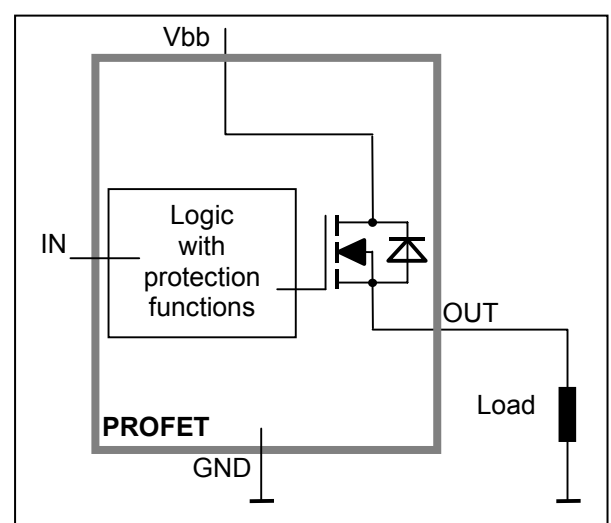
- μC compatible power switch for 5V, 12 V and 24 V DC applications
- All types of resistive, inductive and capacitive loads
- Most suitable for loads with high inrush currents, so as lamps
- Replaces electromechanical relays, fuses and discrete circuits

### Basic Functions

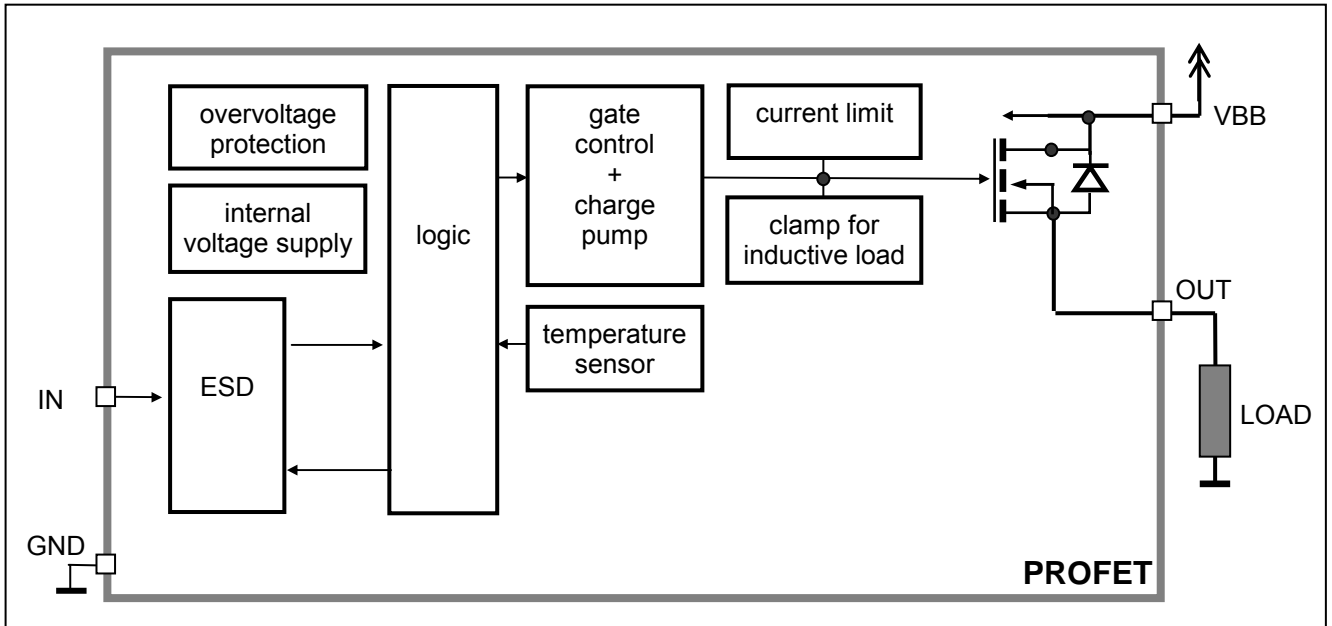
- Very low standby current
- Optimized static electromagnetic compatibility (EMC)
- μC and CMOS compatible
- Fast demagnetization of inductive loads
- Stable behaviour at undervoltage

### Protection Functions

- Short circuit protection
- Current limitation
- Overload protection
- Thermal shutdown
- Overvoltage protection (including load dump) with external GND-resistor
- Reverse battery protection with external GND-resistor
- Loss of ground and loss of V<sub>bb</sub> protection
- Electrostatic discharge (ESD) protection



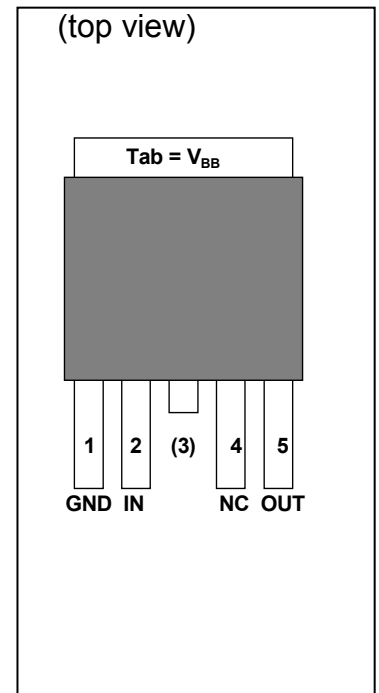
Functional diagram



Pin Definitions and Functions

Pin	Symbol	Function
1	GND	<b>Logic ground</b>
2	IN	<b>Input</b> , activates the power switch in case of logical high signal
3	V <sub>bb</sub>	<b>Positive power supply voltage</b> The tab is shorted to pin 3
4	N.C.	<b>Not connected</b>
5	OUT	<b>Output to the load</b>
Tab	V <sub>bb</sub>	<b>Positive power supply voltage</b> The tab is shorted to pin 3

Pin configuration



**Maximum Ratings** at  $T_j = 25\text{ °C}$  unless otherwise specified

Parameter	Symbol	Values	Unit	
Supply voltage (overvoltage protection see page 4)	$V_{bb}$	43	V	
Supply voltage for full short circuit protection $T_{j\text{ start}} = -40 \dots +150\text{ °C}$	$V_{bb}$	34	V	
Load dump protection <sup>1)</sup> $V_{\text{LoadDump}} = V_A + V_S$ , $V_A = 13.5\text{ V}$ $R_1^2 = 2\ \Omega$ , $R_L = 0,5\ \Omega$ , $t_d = 200\text{ ms}$ , IN= low or high	$V_{\text{Load dump}}^3)$	60	V	
Load current (Short-circuit current, see page 5)	$I_L$	self-limited	A	
Operating temperature range	$T_j$	-40 ... +150	°C	
Storage temperature range	$T_{\text{stg}}$	-55 ... +150		
Power dissipation (DC) ; $T_C \leq 25\text{ °C}$	$P_{\text{tot}}$	125	W	
Maximal switchable inductance, single pulse $V_{bb} = 12\text{ V}$ , $T_{j,\text{start}} = 150\text{ °C}$ , $T_C = 150\text{ °C}$ const. (see diagram, p.8) $I_{L(\text{ISO})} = 21\text{ A}$ , $R_L = 0\ \Omega$ : $E_{\text{AS}} = 0.7\text{ J}$ :	$Z_L$	2.1	mH	
Electrostatic discharge capability (ESD) IN: (Human Body Model) Out to all other pins shorted: acc. MIL-STD883D, method 3015.7 and ESD assn. std. S5.1-1993; $R = 1.5\text{ k}\Omega$ ; $C = 100\text{ pF}$	$V_{\text{ESD}}$	1.0 8.0	kV	
Input voltage (DC)	$V_{\text{IN}}$	-10 ... +16	V	
Current through input pin (DC) see internal circuit diagrams page 7	$I_{\text{IN}}$	$\pm 2.0$	mA	
Thermal resistance	chip - case: junction - ambient (free air): SMD version, device on pcb <sup>5)</sup> :	$R_{\text{thJC}}$ $R_{\text{thJA}}$	$\leq 1$ $\leq 75$ $\leq 33$	K/W

1) Supply voltages higher than  $V_{bb(\text{AZ})}$  require an external current limit for the GND pin, e.g. with a  $150\ \Omega$  resistor in the GND connection. A resistor for the protection of the input is integrated.

2)  $R_1$  = internal resistance of the load dump test pulse generator

3)  $V_{\text{Load dump}}$  is setup without the DUT connected to the generator per ISO 7637-1 and DIN 40839

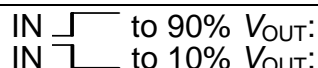
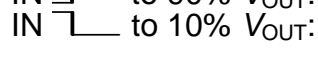
4)  $E_{\text{AS}}$  is the maximum inductive switch off energy

5) Device on  $50\text{ mm} \times 50\text{ mm} \times 1.5\text{ mm}$  epoxy PCB FR4 with  $6\text{ cm}^2$  (one layer,  $70\ \mu\text{m}$  thick) copper area for  $V_{bb}$  connection. PCB is vertical without blown air.

## Electrical Characteristics

Parameter and Conditions at $T_j = -40...+150^\circ\text{C}$ , $V_{bb} = 12\text{ V}$ unless otherwise specified	Symbol	Values			Unit
		min	typ	max	

### Load Switching Capabilities and Characteristics

On-state resistance ( $V_{bb}$ (pin3) to OUT (pin5)); $I_L = 2\text{ A}$ , $V_{bb} \geq 7\text{ V}$ ; $T_j = 25^\circ\text{C}$ : $T_j = 150^\circ\text{C}$ : see diagram page 9	$R_{ON}$	--	15 28	20 37	$\text{m}\Omega$	
Nominal load current (pin 3 to 5) 'ISO 10483-1, 6.7: $V_{ON} = 0.5\text{ V}$ , $T_c = 85^\circ\text{C}$	$I_L(\text{ISO})$	17	21	--	A	
Output current (pin 5) while GND disconnected or GND pulled up <sup>6)</sup> , $V_{bb} = 30\text{ V}$ , $V_{IN} = 0$ , see diagram page 7	$I_L(\text{GNDhigh})$	--	--	2	mA	
Turn-on time Turn-off time $R_L = 12\ \Omega$ ,	IN  IN 	$t_{on}$ $t_{off}$	40 40	90 110	200 250	$\mu\text{s}$
Slew rate on 10 to 30% $V_{OUT}$ , $R_L = 12\ \Omega$ ,	$dV/dt_{on}$	0.1	--	1	$\text{V}/\mu\text{s}$	
Slew rate off 70 to 40% $V_{OUT}$ , $R_L = 12\ \Omega$ ,	$-dV/dt_{off}$	0.1	--	1	$\text{V}/\mu\text{s}$	

### Operating Parameters

Operating voltage	$T_j = -40^\circ\text{C}$ $T_j = +25^\circ\text{C}$ $T_j = +105^\circ\text{C}$ <sup>6)</sup> $T_j = +150^\circ\text{C}$	$V_{bb(\text{on})}$	4.75 4.75 4.75 5.0	-- -- -- --	41 43 43 43	V
Oversvoltage protection <sup>7)</sup> $I_{bb} = 40\text{ mA}$	$T_j = -40^\circ\text{C}$ : $T_j = +25...+150^\circ\text{C}$ :	$V_{bb(\text{AZ})}$	41 43	-- 47	-- 52	V
Standby current (pin 3) <sup>8)</sup> $V_{IN} = 0$ see diagram page 9	$T_j = -40...+25^\circ\text{C}$ : $T_j = +105^\circ\text{C}$ <sup>6)</sup> : $T_j = +150^\circ\text{C}$ :	$I_{bb(\text{off})}$	-- -- --	5 -- --	10 10 25	$\mu\text{A}$
Off-State output current (included in $I_{bb(\text{off})}$ ) $V_{IN} = 0$		$I_L(\text{off})$	--	1.5	10	$\mu\text{A}$
Operating current (Pin 1) <sup>9)</sup> , $V_{IN} = 5\text{ V}$ ,		$I_{GND}$	--	2	4	mA

6) not subject to production test, specified by design

7) see also  $V_{ON(\text{CL})}$  in table of protection functions and circuit diagram page 7

8) Measured with load, typ. 40  $\mu\text{A}$  without load.

9) Add  $I_{IN}$ , if  $V_{IN} > 5.5\text{ V}$



Parameter and Conditions at $T_j = -40...+150^\circ\text{C}$ , $V_{bb} = 12\text{ V}$ unless otherwise specified	Symbol	Values			Unit
		min	typ	max	
<b>Protection Functions<sup>10)</sup></b>					
Current limit (pin 3 to 5) (see timing diagrams, page 9)	$I_{L(\text{lim})}$				
	$T_j = -40^\circ\text{C}$ :	--	--	85	A
	$T_j = 25^\circ\text{C}$ :	--	65	--	
	$T_j = +150^\circ\text{C}$ :	40	--	--	
Repetitive short circuit current limit $T_j = T_{jt}$ (see timing diagrams, page 10)	$I_{L(\text{SCR})}$	--	55	--	A
Thermal shutdown time <sup>11)12)</sup> (see timing diagram on page 10)	$T_{j,\text{start}} = 25^\circ\text{C}$ : $T_{\text{off}(\text{SC})}$	--	14	--	ms
Output clamp (inductive load switch off) at $V_{\text{OUT}} = V_{bb} - V_{\text{ON}(\text{CL})}$ , $I_L = 40\text{ mA}$	$V_{\text{ON}(\text{CL})}$				V
	$T_j = -40^\circ\text{C}$ :	41	--	--	
	$T_j = 25...150^\circ\text{C}$ :	43	47	52	
Thermal overload trip temperature	$T_{jt}$	150	--	--	$^\circ\text{C}$
Thermal hysteresis	$\Delta T_{jt}$	--	10	--	K
Reverse battery (pin 3 to 1) <sup>13)</sup>	$-V_{bb}$	--	--	32	V
Reverse battery voltage drop ( $V_{\text{OUT}} > V_{bb}$ ) $I_L = -2\text{A}$	$-V_{\text{ON}(\text{rev})}$				
	$T_j = +150^\circ\text{C}$ :	--	540	--	mV

<sup>10)</sup> Integrated protection functions are designed to prevent IC destruction under fault conditions described in the data sheet. Fault conditions are considered as "outside" normal operating range. Protection functions are not designed for continuous repetitive operation.

<sup>11)</sup> not subject to production test, specified by design

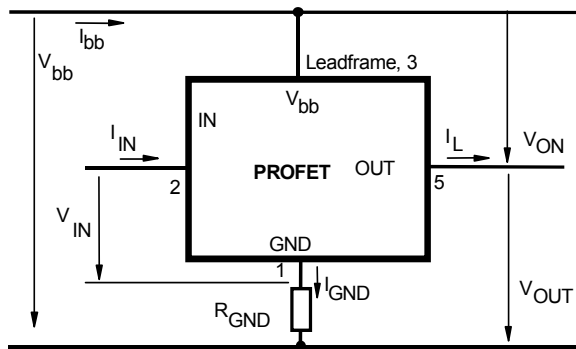
<sup>12)</sup> Device on 50mm\*50mm\*1.5mm epoxy PCB FR4 with 6cm<sup>2</sup> (one layer, 70μm thick) copper area for  $V_{bb}$  connection. PCB is vertical without blown air.

<sup>13)</sup> Requires 150 Ω resistor in GND connection. The reverse load current through the intrinsic drain-source diode has to be limited by the connected load. Note that the power dissipation is higher compared to normal operating conditions due to the voltage drop across the intrinsic drain-source diode. The temperature protection is not active during reverse current operation! Input and Status currents have to be limited (see max. ratings page 1 and circuit page 7).

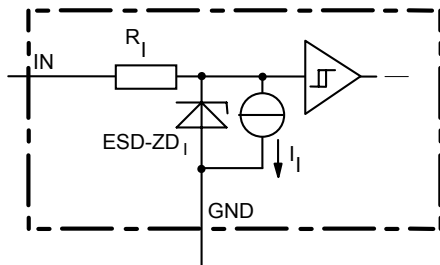
Parameter and Conditions at $T_j = -40...+150^\circ\text{C}$ , $V_{bb} = 12\text{ V}$ unless otherwise specified	Symbol	Values			Unit
		min	typ	max	
<b>Input<sup>14)</sup></b>					
Input resistance <span style="float: right;">see circuit page 7</span>	$R_I$	2.5	3.8	6.5	k $\Omega$
Input turn-on threshold voltage 	$V_{IN(T+)}$	1.2	--	2.2	V
Input turn-off threshold voltage 	$V_{IN(T-)}$	0.8	--	--	V
Input threshold hysteresis	$\Delta V_{IN(T)}$	--	0.3	--	V
Off state input current (pin 2) <span style="float: right;"><math>V_{IN} = 0.4\text{ V}</math>:</span>	$I_{IN(off)}$	1	--	15	$\mu\text{A}$
On state input current (pin 2) <span style="float: right;"><math>V_{IN} = 5\text{ V}</math>:</span>	$I_{IN(on)}$	4.5	12	24	$\mu\text{A}$

<sup>14)</sup> If a ground resistor  $R_{GND}$  is used, add the voltage drop across this resistor.

**Terms**

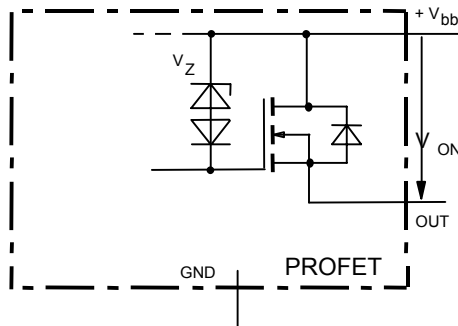


**Input circuit (ESD protection)**



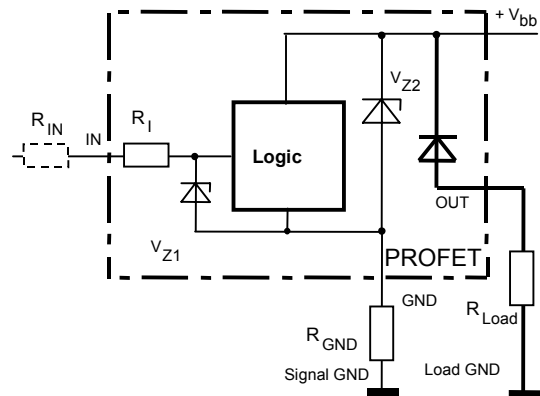
The use of ESD zener diodes as voltage clamp at DC conditions is not recommended.

**Inductive and overvoltage output clamp**



$V_{ON}$  clamped to 47 V typ.

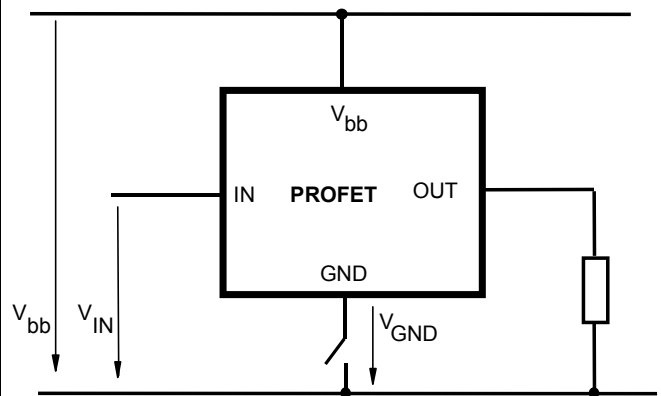
**Overvolt. and reverse batt. protection**



$V_{Z1} = 6.1 \text{ V typ.}$ ,  $V_{Z2} = 47 \text{ V typ.}$ ,  $R_{GND} = 150 \Omega$ ,  $R_I = 3.5 \text{ k}\Omega \text{ typ.}$

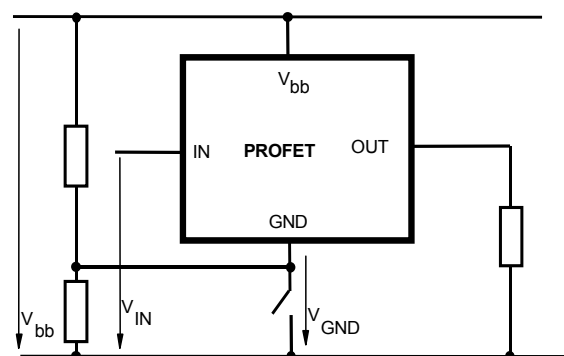
In case of reverse battery the load current has to be limited by the load. Temperature protection is not active

**GND disconnect**



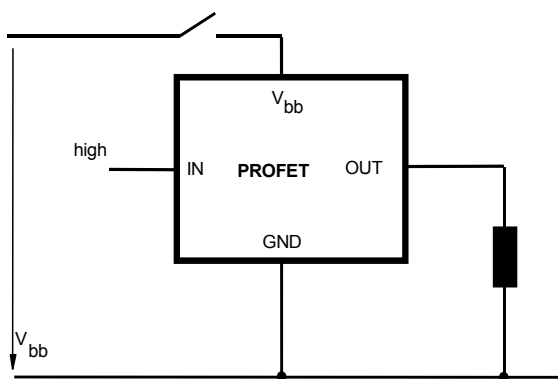
Any kind of load. In case of Input=high is  $V_{OUT} \approx V_{IN} - V_{IN(T+)}$ .

**GND disconnect with GND pull up**



Any kind of load. If  $V_{GND} > V_{IN} - V_{IN(T+)}$  device stays off

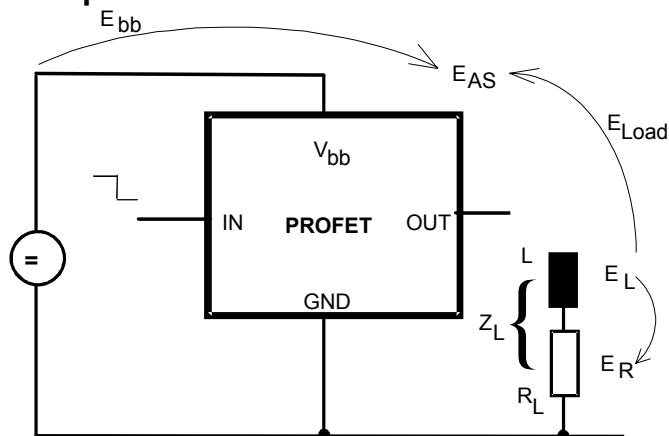
### V<sub>bb</sub> disconnect with charged inductive load



For inductive load currents up to the limits defined by  $Z_L$  (max. ratings and diagram on page 8) each switch is protected against loss of  $V_{bb}$ .

Consider at your PCB layout that in the case of  $V_{bb}$  disconnection with energized inductive load all the load current flows through the GND connection.

### Inductive load switch-off energy dissipation



Energy stored in load inductance:

$$E_L = \frac{1}{2} \cdot L \cdot I_L^2$$

While demagnetizing load inductance, the energy dissipated in PROFET is

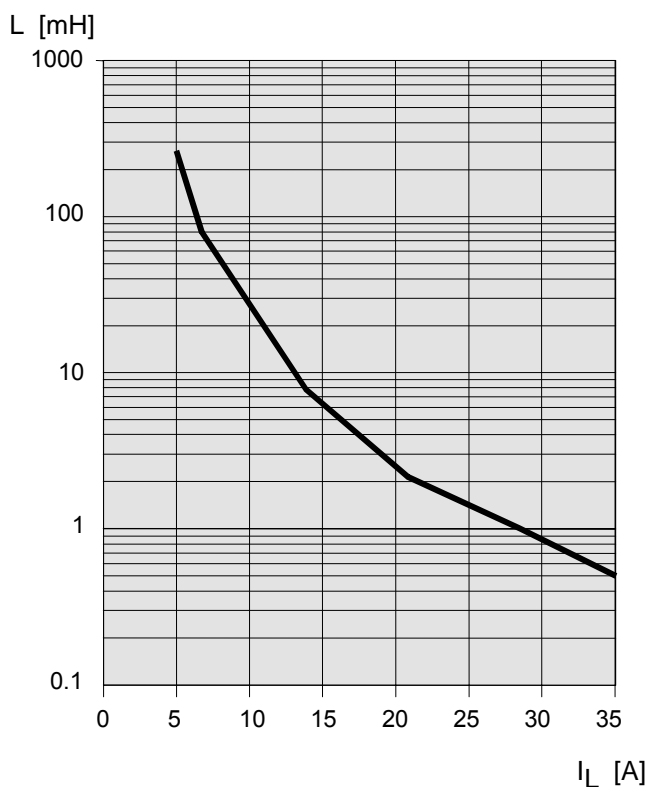
$$E_{AS} = E_{bb} + E_L - E_R = \int V_{ON(CL)} \cdot i_L(t) dt,$$

with an approximate solution for  $R_L > 0 \Omega$ :

$$E_{AS} = \frac{I_L \cdot L}{2 \cdot R_L} (V_{bb} + |V_{OUT(CL)}|) \ln \left( 1 + \frac{I_L \cdot R_L}{|V_{OUT(CL)}|} \right)$$

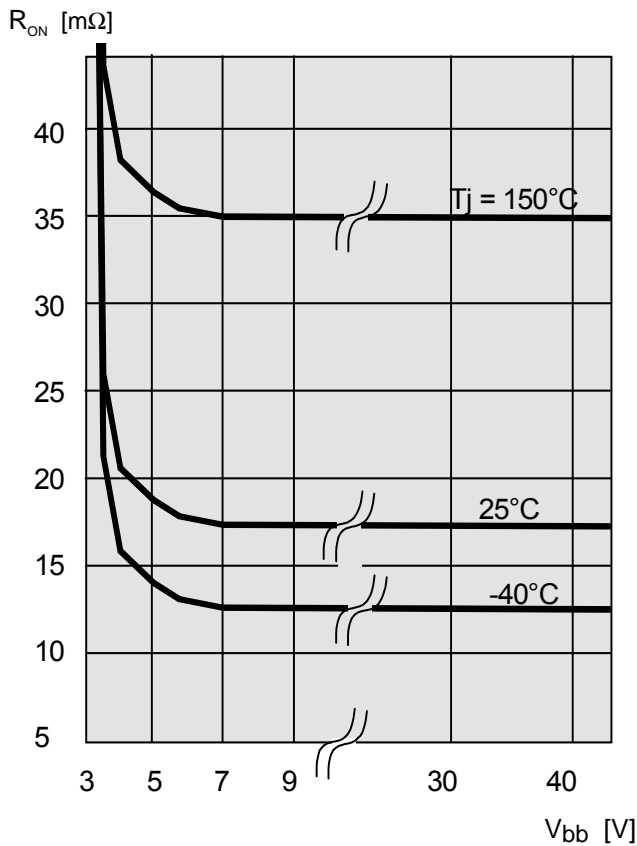
### Maximum allowable load inductance for a single switch off

$$L = f(I_L); T_{j,start} = 150^\circ\text{C}, V_{bb} = 12\text{ V}, R_L = 0 \Omega$$



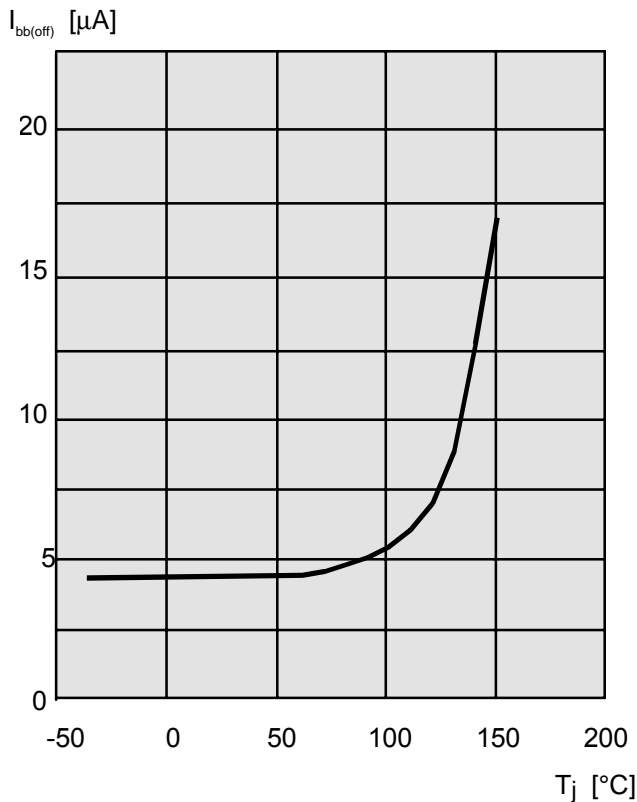
**Typ. on-state resistance**

$R_{ON} = f(V_{bb}, T_j); I_L = 2\text{ A}, I_N = \text{high}$



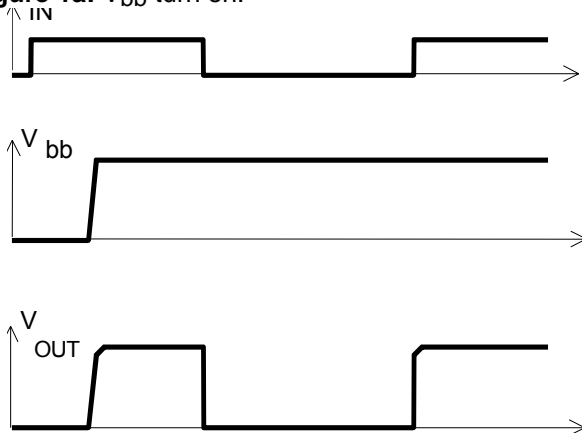
**Typ. standby current**

$I_{bb(off)} = f(T_j); V_{bb} = 9 \dots 34\text{ V}, I_{N1,2} = \text{low}$



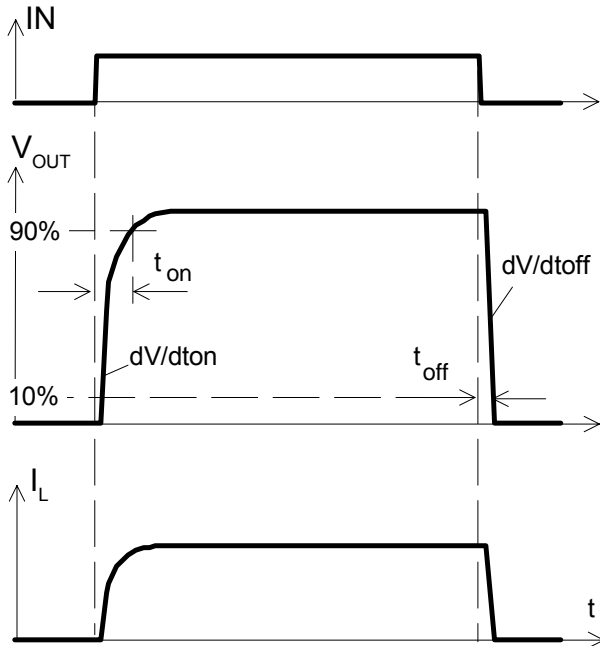
**Timing diagrams**

**Figure 1a:**  $V_{bb}$  turn on:

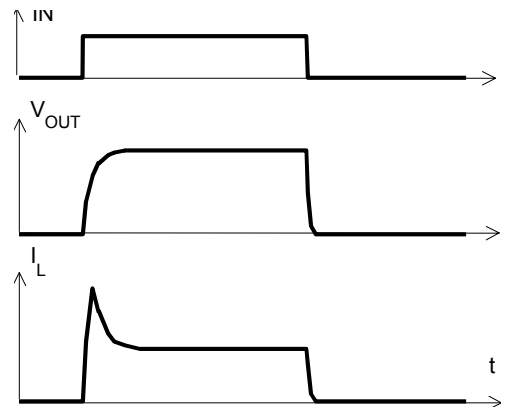


proper turn on under all conditions

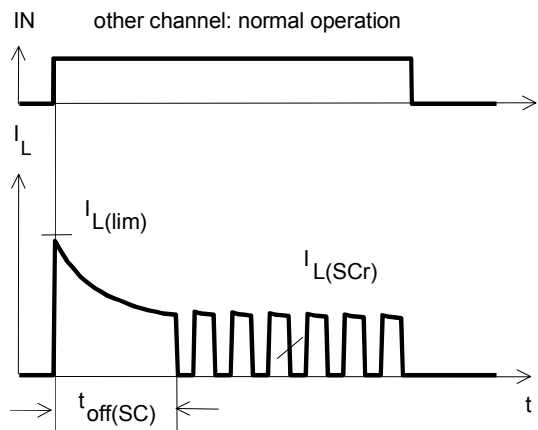
**Figure 2a:** Switching a resistive load, turn-on/off time and slew rate definition:



**Figure 2b:** Switching a lamp,

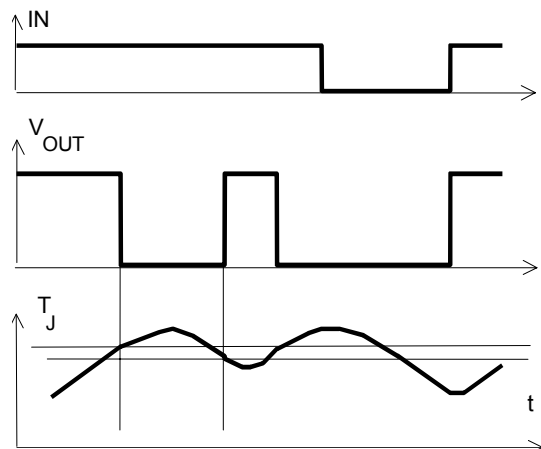


**Figure 3a:** Short circuit shut down by overtemperature, reset by cooling



Heating up may require several milliseconds, depending on external conditions

**Figure 4a:** Overtemperature: Reset if  $T_j < T_{jt}$





This datasheet has been downloaded from:

[www.DatasheetCatalog.com](http://www.DatasheetCatalog.com)

Datasheets for electronic components.



LittleDiode supplies new, hard to find or obsolete electronic components and semiconductors all over the world.

With over two million different components listed you are sure to find the part you need.

Feel free to visit us today at our online store:

[LittleDiode.com](http://LittleDiode.com)

Looking forward to providing you with the best possible service.