

# ADD3701 3<sup>3</sup>/<sub>4</sub> Digit DVM with Multiplexed 7-Segment Output

## General Description

The ADD3701 (MM74C936-1) monolithic DVM circuit is manufactured using standard complementary MOS (CMOS) technology. A pulse modulation analog-to-digital conversion technique is used and requires no external precision components. In addition, this technique allows the use of a reference voltage that is the same polarity as the input voltage.

One 5V (TTL) power supply is required. Operating with an isolated supply allows the conversion of positive as well as negative voltages. The sign of the input voltage is automatically determined and output on the sign pin. If the power supply is not isolated, only one polarity of voltage may be converted.

The conversion rate is set by an internal oscillator. The frequency of the oscillator can be set by an external RC network or the oscillator can be driven from an external frequency source. When using the external RC network, a square wave output is available. It is important to note that great care has been taken to synchronize digit multiplexing with the A/D conversion timing to eliminate noise due to power supply transients.

The ADD3701 has been designed to drive 7-segment multiplexed LED displays directly with the aid of external digit buffers and segment resistors. Under condition of over-range, the overflow output will go high and the display will read +OFL or -OFL, depending on whether the input voltage is positive or negative. In addition to this, the most significant digit is blanked when zero.

A start conversion input and a conversion complete output are included.

## Features

- Operates from single 5V supply
- Converts 0 to ±3999 counts
- Multiplexed 7-segment
- Drives segments directly
- No external precision components necessary
- Accuracy specified over temperature
- Medium speed — 400 ms/conversion
- Internal clock set with RC network or driven externally
- Overrange indicated by +OFL or -OFL display reading and OFLO output
- Analog inputs in applications shown can withstand ±200 Volts
- ADD3701 equivalent to MM74C936-1

## Applications

- Low cost digital power supply readouts
- Low cost digital multimeters
- Low cost digital panel meters
- Eliminate analog multiplexing by using remote A/D converters
- Convert analog transducers (temperature, pressure, displacement, etc.) to digital transducers
- Indicators and displays requiring readout up to 3999 counts

## Connection Diagram

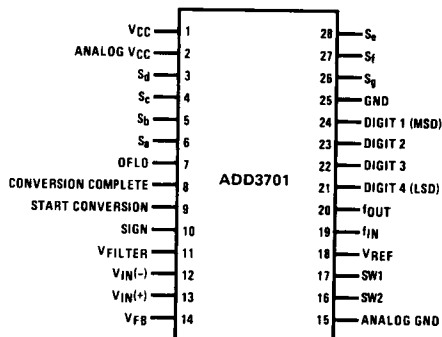

Order Number ADD3701CCN  
See NS Package Number N28B

TL/H/5682-1

## Absolute Maximum Ratings (Note 1)

If Military/Aerospace specified devices are required, please contact the National Semiconductor Sales Office/Distributors for availability and specifications.

Voltage at Any Pin except Start Conversion	-0.3V to $V_{CC} + 0.3V$
Voltage at Start Conversion	-0.3V to +15.0V
ESD Susceptibility (Note 5)	TBDV

Operating Temperature Range ( $T_A$ )	-40°C to +85°C
Package Dissipation at $T_A = 25^\circ C$	800mW
Operating $V_{CC}$ Range	4.5V to 6.0V
Absolute Maximum $V_{CC}$	6.5V
Lead Temp. (Soldering, 10 seconds)	260°C
Storage Temperature Range	-65°C to +150°C

## Electrical Characteristics

4.75V  $\leq V_{CC} \leq 5.25V$ ,  $-40^\circ C \leq T_A \leq +85^\circ C$ , unless otherwise specified.

Parameter	Conditions	Min	Typ <sup>2</sup>	Max	Units
$V_{IN(1)}$	Logical "1" Input Voltage	$V_{CC} - 1.5$			V
$V_{IN(0)}$	Logical "0" Input Voltage			1.5	V
$V_{OUT(0)}$	Logical "0" Output Voltage (All Digital Outputs Except Digital Outputs)	$I_O = 1.1 \text{ mA}$		0.4	V
$V_{OUT(0)}$	Logical "0" Output Voltage (Digit Outputs)	$I_O = 0.7 \text{ mA}$		0.4	V
$V_{OUT(1)}$	Logical "1" Output Voltage (All Segment Outputs)	$I_O = 50 \text{ mA} @ T_J = 25^\circ C$ $I_O = 30 \text{ mA} @ T_J = 100^\circ C$ $V_{CC} = 5V$	$V_{CC} - 1.6$ $V_{CC} - 1.6$	$V_{CC} - 1.3$ $V_{CC} - 1.3$	V V
$V_{OUT(1)}$	Logical "1" Output Voltage (All Digital Outputs Except Segment Outputs)	$I_O = 500 \mu A$ (Digit Outputs) $I_O = 360 \mu A$ (Conv. Complete, + / -, OFLO Outputs)	$V_{CC} - 0.4$		V
$I_{SOURCE}$	Output Source Current (Digital Outputs)	$V_{OUT} = 1.0 \text{ V}$	2.0		mA
$I_{IN(1)}$	Logical "1" Input Current (Start Conversion)	$V_{IN} = 15V$		1.0	$\mu A$
$I_{IN(0)}$	Logical "0" Input Current (Start Conversion)	$V_{IN} = 0V$	-1.0		$\mu A$
$I_{CC}$	Supply Current	Segments and Digits Open		0.5	10 mA
$f_{OSC}$	Oscillator Frequency		0.6/RC		kHz
$f_{IN}$	Clock Frequency		100	640	kHz
$f_C$	Conversion Rate			$f_{IN}/129,024$	conv./sec
$f_{MUX}$	Digit Mux Rate			$f_{IN}/512$	Hz
$t_{BLANK}$	Inter Digit Blanking Time			$1/(32f_{MUX})$	seconds
$t_{SCPW}$	Start Conversion Pulse Width		200	DC	ns

**Note 1:** Absolute Maximum Ratings indicate limits beyond which damage to the device may occur. DC and AC electrical specifications do not apply when operating the device beyond its specified operating conditions.

**Note 2:** All typicals given for  $T_A = 25^\circ C$ .

**Note 3:** Full scale = 4000 counts; therefore 0.025% of full scale = 1 count and 0.05% of full scale = 2 counts.

**Note 4:** For 2.000 Volts full scale, 1 mV = 2 counts.

**Note 5:** Human body model, 100 pF discharged through a 1.5 k $\Omega$  resistor.

# Electrical Characteristics (Continued)

$t_C = 2.5$  conversions/second,  $0^\circ C \leq T_A \leq +70^\circ C$ , unless otherwise specified.

Parameter	Conditions	Min	Typ <sup>2</sup>	Max	Units
Non-Linearity of Output Reading	$V_{IN} = 0 - 2V$ Full Scale $V_{IN} = 0 - 200$ mV Full Scale	-0.05 -0.05	$\pm 0.025$ $\pm 0.025$	$\pm 0.05$ $\pm 0.05$	% full scale (Note 3)
Quantization Error		-1		+0	counts
Offset Error, $V_{IN} = 0V$		-0.5	+1.5	+3	mV (Note 4)
Rollover Error		-0		+0	counts
Analog Input Current ( $V_{IN+}$ , $V_{IN-}$ )	$T_A = 25^\circ C$	-5	$\pm 1$	+5	nA

## Block Diagram

ADD3701 3<sup>3</sup>/<sub>4</sub>-Digit DVM

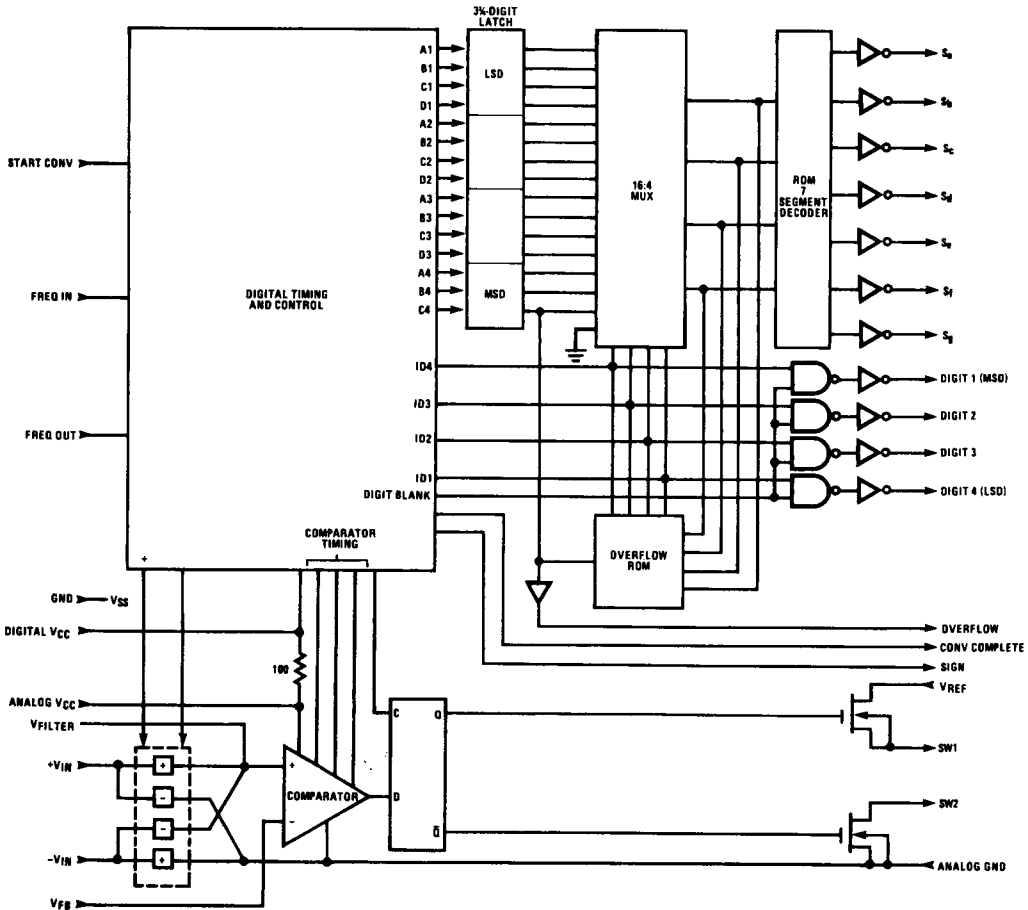

## Theory of Operation

A schematic for the analog loop is shown in *Figure 1*. The output of SW1 is either at  $V_{REF}$  or zero volts, depending on the state of the D flip-flop. If Q is at a high level,  $V_{OUT} = V_{REF}$  and if Q is at a low level  $V_{OUT} = 0V$ . This voltage is then applied to the low pass filter comprised of R1 and C1. The output of this filter,  $V_{FB}$ , is connected to the negative input of the comparator, where it is compared to the analog input voltage,  $V_{IN}$ . The output of the comparator is connected to the D input of the D flip-flop. Information is then transferred from the D input to the Q and Q outputs on the positive edge of clock. This loop forms an oscillator whose duty cycle is precisely related to the analog input voltage,  $V_{IN}$ .

An example will demonstrate this relationship. Assume the input voltage is equal to 0.500 V. If the Q output of the D flip-flop is high then  $V_{OUT}$  will equal  $V_{REF}$  (2.000 V) and  $V_{FB}$  will charge toward 2 V with a time constant equal to  $R_1C_1$ . At some time  $V_{FB}$  will exceed 0.500 V and the comparator output will switch to 0V. At the next clock rising edge the Q output of the D flip-flop will switch to ground, causing  $V_{OUT}$  to switch to 0V. At this time  $V_{FB}$  will start discharging toward 0V with a time constant  $R_1C_1$ . When  $V_{FB}$  is less than 0.5 V the comparator output will switch high. On the rising edge of the next clock the Q output of the D flip-flop will switch high and the process will repeat. There exists at the output of SW1 a square wave pulse train with positive amplitude  $V_{REF}$  and negative amplitude 0V.

The DC value of this pulse train is:

$$V_{OUT} = V_{REF} \frac{t_{ON}}{t_{ON} + t_{OFF}} = V_{REF} (\text{duty cycle})$$

The lowpass filter will pass the DC value and then:

$$V_{FB} = V_{REF} (\text{duty cycle})$$

Since the closed loop system will always force  $V_{FB}$  to equal  $V_{IN}$ , we can then say that:

$$V_{IN} = V_{FB} = V_{REF} (\text{duty cycle})$$

or

$$\frac{V_{IN}}{V_{REF}} = (\text{duty cycle})$$

The duty cycle is logically ANDed with the input frequency  $f_{IN}$ . The resultant frequency  $f$  equals:

$$f = (\text{duty cycle}) \times (\text{clock})$$

Frequency  $f$  is accumulated by counter no. 1 for a time determined by counter no. 2. The count contained in counter no. 1 is then:

$$\begin{aligned} (\text{count}) &= \frac{f}{(\text{clock})/N} = \frac{(\text{duty cycle}) \times (\text{clock})}{(\text{clock})/N} \\ &= \frac{V_{IN}}{V_{REF}} \times N \end{aligned}$$

For the ADD3701  $N = 4000$ .

## Schematic Diagram

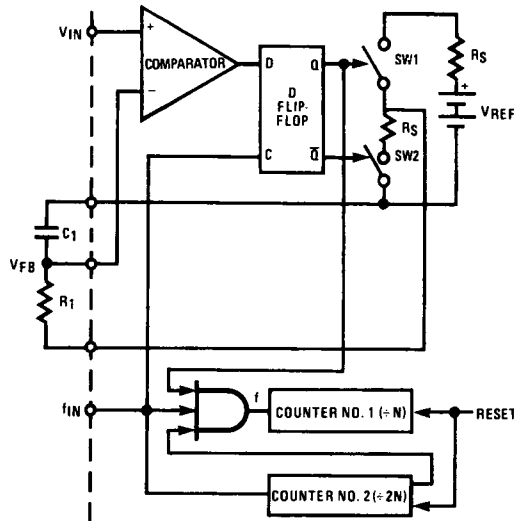

$$V_{IN} = V_{FB} = V_{REF} \times (\text{duty cycle})$$

$$f = (\text{duty cycle}) \times f_{IN}$$

$$\text{Count in Counter No. 1} = \frac{f}{f_{IN}/N} = \frac{(\text{duty cycle}) \times f_{IN}}{f_{IN}/N} = \frac{V_{IN}}{V_{REF}} \times N$$

TL/H/5682-3

FIGURE 1. Analog Loop Schematic Pulse Modulation A/D Converter

## General Information

The timing diagram, shown in *Figure 2*, gives operation for the free running mode. Free running operation is obtained by connecting the Start Conversion input to logic "1" ( $V_{CC}$ ). In this mode the analog input is continuously converted and the display is updated at a rate equal to  $129,024 \times 1/f_{IN}$ .

The rising edge of the Conversion Complete output indicates that new information has been transferred from the internal counter to the display latch. This information will remain in the display latch until the next low-to-high transition of the Conversion Complete output. A logic "1" will be maintained on the Conversion Complete output for a time equal to  $128 \times 1/f_{IN}$ .

*Figure 3* gives the operation using the Start Conversion input. It is important to note that the Start Conversion input and Conversion Complete output do not influence the actual analog-to-digital conversion in any way.

Internally the ADD3701 is always continuously converting the analog voltage present at its input. The Start Conversion input is used to control the transfer of information from the internal counter to the display latch.

An RS latch on the Start Conversion input allows a broad range of input pulse widths to be used on this signal. As shown in *Figure 3*, the Conversion Complete output goes to a logic "0" on the rising edge of the Start Conversion pulse and goes to a logic "1" some time later when the new conversion is transferred from the internal counter to the display latch. Since the Start Conversion pulse can occur at any time during the conversion cycle, the amount of time from Start Conversion to Conversion Complete will vary. The maximum time is  $129,024 \times 1/f_{IN}$  and the minimum time is  $512 \times 1/f_{IN}$ .

## Timing Waveforms

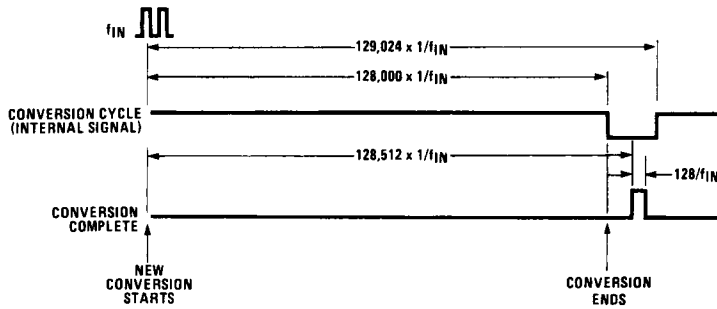

TL/H/5682-4

FIGURE 2. Conversion Cycle Timing Diagram for Free Running Operation

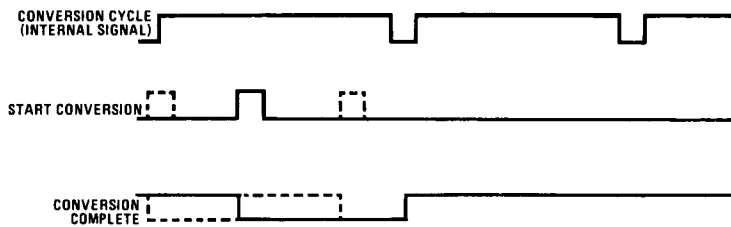

TL/H/5682-5

FIGURE 3. Conversion Cycle Timing Diagram Operating with Start Conversion Input

## Applications

### SYSTEM DESIGN CONSIDERATIONS

Perhaps the most important thing to consider when designing a system using the ADD3701 is power supply noise on the  $V_{CC}$  and ground lines. Because a single power supply is used and currents in the 300 mA range are being switched, good circuit layout techniques cannot be overemphasized. Great care has been exercised in the design of the ADD3701 to minimize these problems but poor printed circuit layout can negate these features.

*Figures 4, 5, and 6* show schematics of DVM systems. An attempt has been made to show, on these schematics, the proper distribution for ground and  $V_{CC}$ . To help isolate digital and analog portions of the circuit, the analog  $V_{CC}$  and ground have been separated from the digital  $V_{CC}$  and ground. Care must be taken to eliminate high current from flowing in the analog  $V_{CC}$  and ground wires. The most effective method of accomplishing this is to use a single ground point and a single  $V_{CC}$  point where all wires are brought together. In addition to this the conductors must be of sufficient size to prevent significant voltage drops.

To prevent switching noise from causing jitter problems, a voltage regulator with good high frequency response is necessary. The LM309 and the LM340-5 voltage regulators all function well and are shown in *Figures 4, 5, and 6*. Adding more filtering than is shown will in general increase the jitter rather than decrease it.

The most important characteristics of transients on the  $V_{CC}$  line is the duration of the transient and not its amplitude.

*Figure 4* shows a DPM system which converts 0 to +3.999 counts operating from a non-isolated power supply. In this configuration the sign output could be + (logic "1") or - (logic "0") and it should be ignored. Higher voltages could be converted by placing a fixed divider on the input; lower voltages could be converted by placing a fixed divider on the feedback, as shown in *Figure 5*.

*Figures 5 and 6* show systems operating with an isolated supply that will convert positive and negative inputs. 60 Hz common mode input becomes a problem in this configuration and a transformer with an electrostatic shield between primary and secondary windings is shown. The necessity for using a shielded transformer depends on the performance requirements and the actual application.

The filter capacitors connected to  $V_{FB}$  (pin 14) and  $V_{FLT}$  (pin 11) should be low leakage. In the application examples shown every 1.0 nA of leakage current will cause 0.1 mV error ( $1.0 \times 10^{-9} \text{A} \times 100 \text{k}\Omega = 0.1 \text{mV}$ ). If the leakage current in both capacitors is exactly the same no error will result since the source impedances driving them are matched.





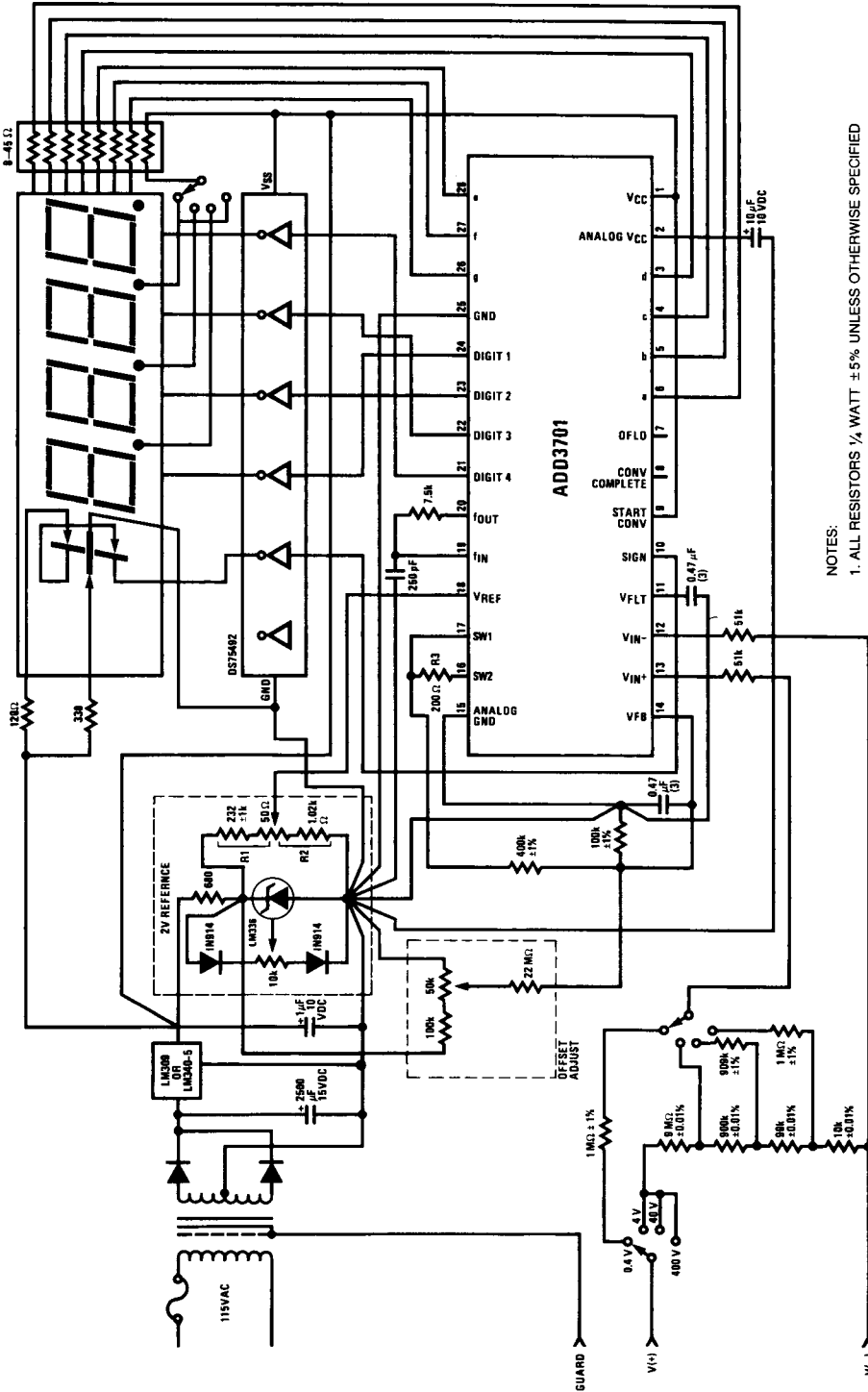

- NOTES:
1. ALL RESISTORS 1/4 WATT ± 5% UNLESS OTHERWISE SPECIFIED
  2. ALL CAPACITORS ± 10%.
  3. LOW LEAKAGE CAPACITOR REQUIRED.
  4.  $R_1R_2 = R_3 \pm 25\Omega$ .

TL/H/5862-8

Figure 6. 3 3/4-Digit DVM, Four Decade, ± 0.4V, ± 40V, ± 400V Full Scale

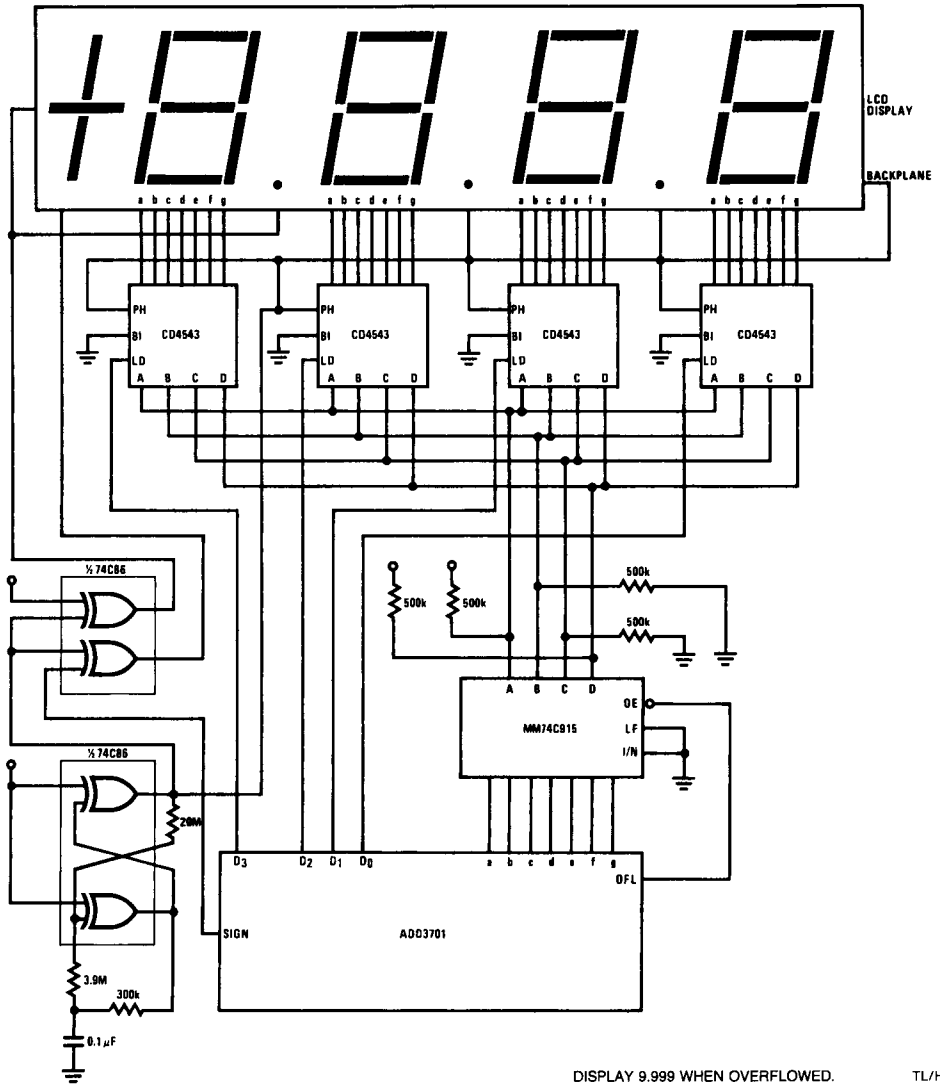

DISPLAY 9.999 WHEN OVERFLOWED.  
 ALL DIGITS CAN ALSO BE BLANKED AT  
 OVERFLOW BY TYING OFL TO B1 ON THE  
 CD4543s.

TL/H/5682-9

Figure 7. ADD3701 Driving Liquid Crystal Display

This datasheet has been downloaded from:

[www.DatasheetCatalog.com](http://www.DatasheetCatalog.com)

Datasheets for electronic components.

# National Semiconductor was acquired by Texas Instruments.

[http://www.ti.com/corp/docs/investor\\_relations/pr\\_09\\_23\\_2011\\_national\\_semiconductor.html](http://www.ti.com/corp/docs/investor_relations/pr_09_23_2011_national_semiconductor.html)

This file is the datasheet for the following electronic components:

ADD3701 - <http://www.ti.com/product/add3701?HQS=TI-null-null-dscatalog-df-pf-null-ww>



LittleDiode supplies new, hard to find or obsolete electronic components and semiconductors all over the world.

With over two million different components listed you are sure to find the part you need.

Feel free to visit us today at our online store:

[LittleDiode.com](http://LittleDiode.com)

Looking forward to providing you with the best possible service.