

MITSUBISHI RF POWER MOS FET
2SK2975

DESCRIPTION

2SK2975 is a MOS FET type transistor specifically designed for VHF/UHF power amplifiers applications.

FEATURES

- High power gain: G_{pe} 8.4dB
@ $V_{DD}=9.6V, f=450MHz, P_{in}=30dBm$
- High efficiency: 55% typ.
- Source case type seramic package
(connected internally to source)

APPLICATION

For drive stage and output stage of power amplifiers in VHF/UHF band portable radio sets.

OUTLINE DRAWING

Dimensions in mm

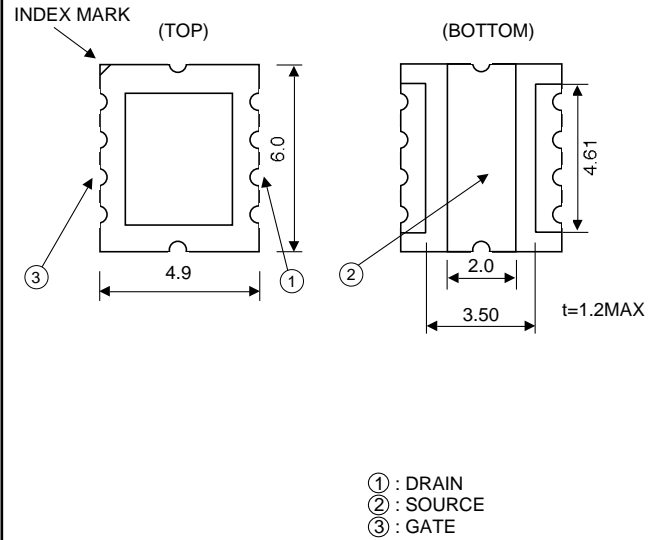

MARKING

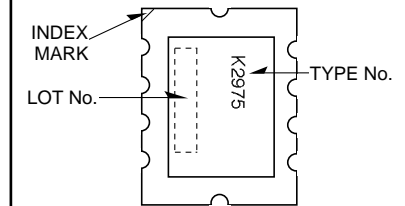

ABSOLUTE MAXIMUM RATINGS ($T_c=25^\circ C$, unless otherwise noted)

Symbol	Parameter	Conditions	Ratings	Unit
V_{DSS}	Drain to source voltage		30	V
V_{GSS}	Gate to source voltage		± 20	V
P_{ch}	Channel dissipation	$T_c=25^\circ C$ (Note2)	10	W
T_j	Junction temperature		175	$^\circ C$
T_{stg}	Storage temperature		-40 to +110	$^\circ C$

Note1: Above parameters are guaranteed independently.
2: Solder source pad on Copper Block(14×2.8×2mm)

ELECTRICAL CHARACTERISTICS ($T_c=25^\circ C$, unless otherwise noted)

Symbol	Parameter	Test conditions	Limits			Unit
			Min	Typ	Max	
I_{DSS}		$V_{DS}=17V, V_{GS}=0V$	—	—	10	μA
I_{GSS}		$V_{GS}=10V, V_{DS}=0V$	—	—	1	μA
V_{TH}	Threshold voltage	$V_{DS}=7V, I_{DS}=1mA$	1.0		1.7	V
C_{iss}		$V_{GS}=10V, V_{DS}=0V, f=1MHz$		45		pF
C_{oss}		$V_{DS}=10V, V_{GS}=0V, f=1MHz$		80		pF
P_{out}		$V_{DS}=9.6V, P_{in}=1W, f=450MHz$	7	8		W
hD			50	55		%

Note: Above parameters, ratings, limits and conditions are subject to change.

TYPICAL PERFORMANCE DATA

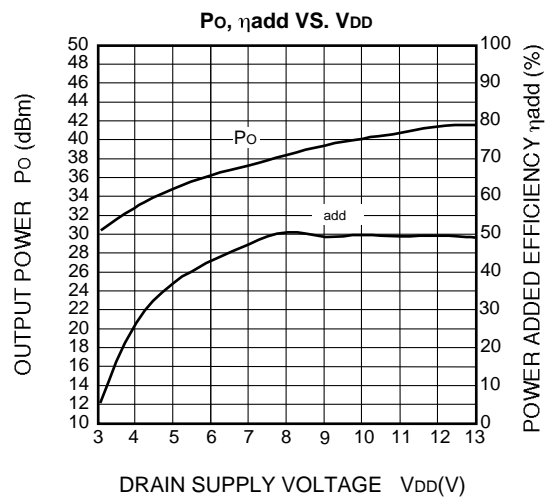
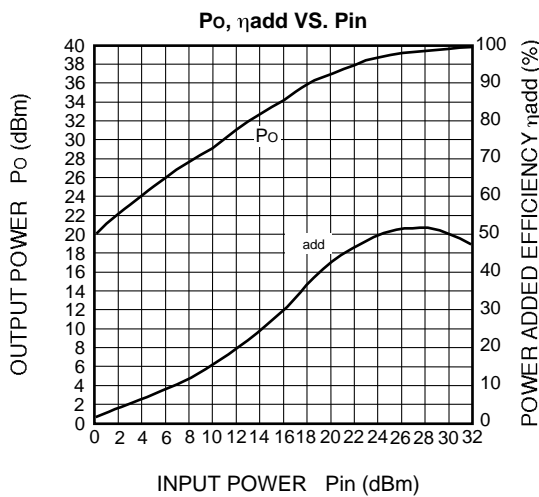
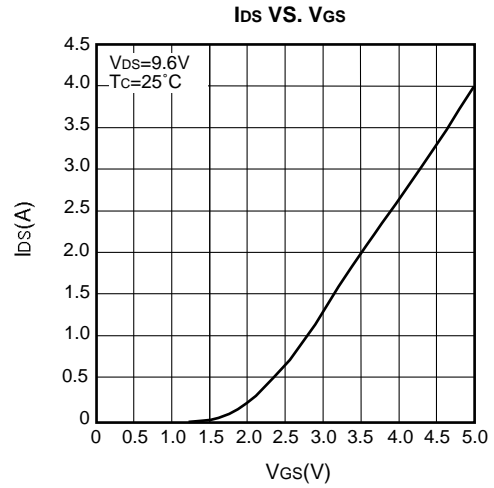
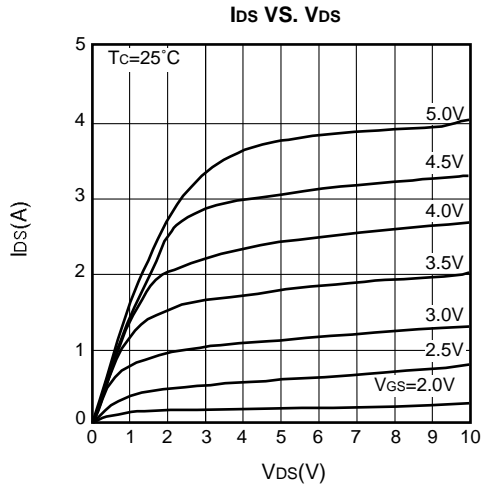

EQUIVALENT CIRCUIT

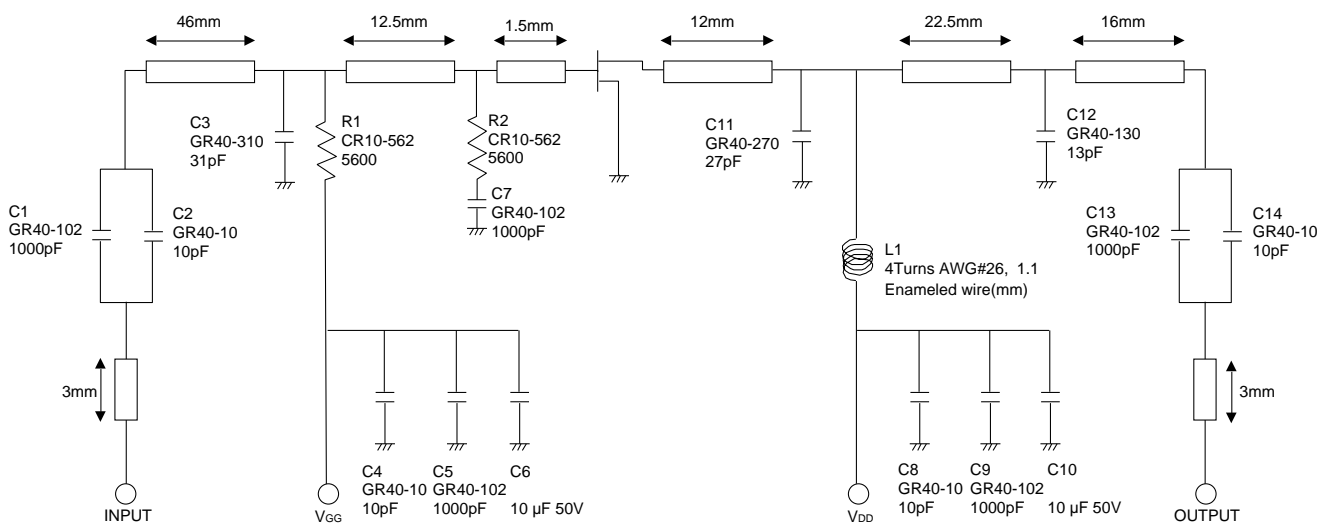

Note: Board material-glass epoxy substrate
 micro strip line width=2.8mm, $r:4.8, t=1.6\text{mm}$

mitsubishi rf power mos fet
2SK2975

S-PARAMETER DATA(TYPICAL)

V_D=9.6V, *P_{in}*=10dBm

FREQ. (MHz)	S ₁₁		S ₁₂		S ₂₁		S ₂₂	
	Mag	Phase	Mag	Phase	Mag	Phase	Mag	Phase
50	0.836	-115.463	0.021	11.967	19.136	97.418	0.559	-143.723
100	0.807	-141.825	0.021	-16.870	10.141	65.065	0.636	-154.490
150	0.819	-151.724	0.020	-37.649	6.556	40.799	0.680	-158.082
200	0.835	-156.464	0.018	-50.731	4.625	20.767	0.720	-159.659
250	0.858	-159.472	0.016	-62.227	3.475	2.085	0.759	-160.702
300	0.872	-161.678	0.014	-72.477	2.709	-14.865	0.778	-161.884
350	0.886	-163.630	0.012	-77.156	2.175	-30.984	0.807	-163.331
400	0.899	-165.272	0.010	-82.951	1.788	-46.429	0.830	-164.014
450	0.909	-166.371	0.010	-79.763	1.501	-61.362	0.839	-164.860
500	0.915	-167.628	0.010	-77.947	1.279	-75.599	0.858	-165.663
550	0.924	-168.601	0.010	-77.893	1.107	-89.665	0.869	-166.475
600	0.930	-169.541	0.011	-76.571	0.969	-103.303	0.874	-166.923
650	0.933	-170.535	0.013	-82.268	0.855	-116.569	0.885	-167.633
700	0.935	-171.602	0.015	-88.668	0.759	-130.173	0.891	-168.317
750	0.944	-172.164	0.017	-93.156	0.690	-143.380	0.893	-168.904
800	0.946	-173.164	0.019	-103.513	0.625	-156.123	0.905	-169.826
850	0.948	-173.673	0.021	-113.867	0.570	-169.394	0.908	-170.437
900	0.949	-174.773	0.024	-124.065	0.525	-177.293	0.909	-171.046
950	0.951	-175.444	0.026	-134.453	0.487	-165.298	0.915	-171.892
1000	0.956	-175.951	0.028	-144.025	0.446	-152.305	0.915	-172.318
1050	0.957	-177.019	0.031	-157.299	0.411	-139.706	0.915	-173.122
1100	0.954	-177.922	0.033	-169.332	0.386	-127.148	0.924	-174.349
1150	0.953	-178.800	0.035	-179.717	0.368	-115.532	0.926	-174.354
1200	0.954	-179.511	0.038	-167.673	0.337	-102.465	0.925	-174.989
1250	0.956	-179.625	0.040	-155.999	0.323	-90.520	0.930	-175.742
1300	0.954	-178.904	0.042	-144.195	0.303	-78.449	0.927	-176.300
1350	0.954	-177.726	0.045	-132.079	0.287	-66.533	0.929	-177.658
1400	0.950	-176.753	0.046	-119.508	0.270	-53.720	0.927	-178.157
1450	0.950	-175.847	0.049	-107.540	0.260	-41.671	0.931	-178.520
1500	0.950	-174.793	0.051	-95.929	0.244	-29.932	0.927	-179.724



LittleDiode supplies new, hard to find or obsolete electronic components and semiconductors all over the world.

With over two million different components listed you are sure to find the part you need.

Feel free to visit us today at our online store:

LittleDiode.com

Looking forward to providing you with the best possible service.