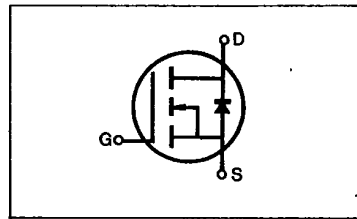
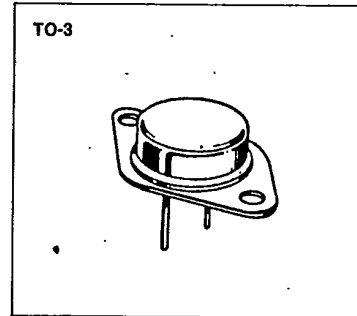

IRF440/441/442/443**N-CHANNEL
POWER MOSFETS****FEATURES**

- Low $R_{DS(on)}$ at high voltage
- Improved inductive ruggedness
- Excellent high voltage stability
- Fast switching times
- Rugged polysilicon gate cell structure
- Low input capacitance
- Extended safe operating area
- Improved high temperature reliability
- TO-3 package (High voltage)

**PRODUCT SUMMARY**

Part Number	V_{DS}	$R_{DS(on)}$	I_D
IRF440	500V	0.85 Ω	8.0A
IRF441	450V	0.85 Ω	8.0A
IRF442	500V	1.10 Ω	7.0A
IRF443	450V	1.10 Ω	7.0A

MAXIMUM RATINGS

Characteristic	Symbol	IRF440	IRF441	IRF442	IRF443	Unit
Drain-Source Voltage (1)	V_{DS}	500	450	500	450	Vdc
Drain-Gate Voltage ($R_{GS}=1.0M\Omega$) (1)	V_{DGR}	500	450	500	450	Vdc
Gate-Source Voltage	V_{GS}	± 20				Vdc
Continuous Drain Current $T_C=25^\circ C$	I_D	8.0	8.0	7.0	7.0	Adc
Continuous Drain Current $T_C=100^\circ C$	I_D	5.0	5.0	4.0	4.0	Adc
Drain Current—Pulsed (3)	I_{DM}	32	32	28	28	Adc
Gate Current—Pulsed	I_{GM}	± 1.5				Adc
Total Power Dissipation @ $T_C=25^\circ C$ Derate above $25^\circ C$	P_D	125 1.0				Watts W/ $^\circ C$
Operating and Storage Junction Temperature Range	T_J, T_{stg}	-55 to 150				$^\circ C$
Maximum Lead Temp. for Soldering Purposes, 1/8" from case for 5 seconds	T_L	300				$^\circ C$

Notes: (1) $T_J=25^\circ C$ to $150^\circ C$

(2) Pulse test: Pulse width $\leq 300\mu s$, Duty Cycle $\leq 2\%$

(3) Repetitive rating: Pulse width limited by max. junction temperature

IRF440/441/442/443**N-CHANNEL
POWER MOSFETS****ELECTRICAL CHARACTERISTICS** ($T_C=25^\circ\text{C}$ unless otherwise specified)

Characteristic	Symbol	Type	Min	Typ	Max	Units	Test Conditions
Drain-Source Breakdown Voltage	BV_{DSS}	IRF440 IRF442	500	—	—	V	$V_{GS}=0V$
		IRF441 IRF443	450	—	—	V	$I_D=250\mu A$
Gate Threshold Voltage	$V_{GS(th)}$	ALL	2.0	—	4.0	V	$V_{DS}=V_{GS}$, $I_D=250\mu A$
Gate-Source Leakage Forward	I_{GSS}	ALL	—	—	100	nA	$V_{GS}=20V$
Gate-Source Leakage Reverse	I_{GSS}	ALL	—	—	-100	nA	$V_{GS}=-20V$
Zero Gate Voltage Drain Current	I_{DSS}	ALL	—	—	250	μA	$V_{DS}=\text{Max. Rating}$, $V_{GS}=0V$
		ALL	—	—	1000	μA	$V_{DS}=\text{Max. Rating} \times 0.8$, $V_{GS}=0V$, $T_C=125^\circ\text{C}$
On-State Drain-Source Current (2)	$I_{D(on)}$	IRF440 IRF441	8.0	—	—	A	$V_{DS} > I_{D(on)} \times R_{DS(on) \text{ max.}}$, $V_{GS}=10V$
		IRF442 IRF443	7.0	—	—	A	
Static Drain-Source On-State Resistance (2)	$R_{DS(on)}$	IRF440 IRF441	—	0.6	0.85	Ω	$V_{GS}=10V$, $I_D=4.0A$
		IRF442 IRF443	—	1.0	1.1	Ω	
Forward Transconductance (2)	g_{fs}	ALL	4.0	6.5	—	Ω	$V_{DS} > I_{D(on)} \times R_{DS(on) \text{ max.}}$, $I_D=4.0A$
Input Capacitance	C_{iss}	ALL	—	1200	1600	pF	$V_{GS}=0V$, $V_{DS}=25V$, $f=1.0\text{MHz}$
Output Capacitance	C_{oss}	ALL	—	230	350	pF	
Reverse Transfer Capacitance	C_{rss}	ALL	—	65	150	pF	
Turn-On Delay Time	$t_{d(on)}$	ALL	—	—	35	ns	
Rise Time	t_r	ALL	—	—	15	ns	$V_{DD}=0.5BV_{DSS}$, $I_D=4.0A$, $Z_\theta=4.7\Omega$ (MOSFET switching times are essentially independent of operating temperature.)
Turn-Off Delay Time	$t_{d(off)}$	ALL	—	—	90	ns	
Fall Time	t_f	ALL	—	—	30	ns	
Total Gate Charge (Gate-Source Plus Gate-Drain)	Q_g	ALL	—	34	60	nC	$V_{GS}=10V$, $I_D=10A$, $V_{DS}=0.8 \text{ Max. Rating}$ (Gate charge is essentially independent of operating temperature.)
Gate-Source Charge	Q_{gs}	ALL	—	6.0	—	nC	
Gate-Drain ("Miller") Charge	Q_{gd}	ALL	—	28	—	nC	

THERMAL RESISTANCE

Junction to Case	R_{thJC}	ALL	—	—	1.0	K/W	
Case-to-Sink	R_{thCS}	ALL	—	0.1	—	K/W	Mounting surface flat, smooth, and greased
Junction-to-Ambient	R_{thJA}	ALL	—	—	30	K/W	Free Air Operation

Notes: (1) $T_C=25^\circ\text{C}$ to 150°C (2) Pulse test: Pulse width $\leq 300\mu s$, Duty Cycle $\leq 2\%$

(3) Repetitive rating: Pulse width limited by max. junction temperature



IRF440/441/442/443

**N-CHANNEL
POWER MOSFETS**

SOURCE-DRAIN DIODE RATINGS AND CHARACTERISTICS

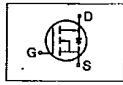
Characteristic	Symbol	Type	Min	Typ	Max	Units	Test Conditions
Continuous Source Current (Body Diode)	I _S	IRF440	—	—	8.0	A	Modified MOSFET symbol showing the integral reverse P-N junction rectifier 
		IRF441	—	—	8.0	A	
		IRF442	—	—	7.0	A	
		IRF443	—	—	7.0	A	
Pulse Source Current (Body Diode) (3)	I _{SM}	IRF440	—	—	32	A	
		IRF441	—	—	32	A	
		IRF442	—	—	28	A	
		IRF443	—	—	28	A	
Diode Forward Voltage (2)	V _{SD}	IRF440	—	—	2.0	V	T _C =25°C, I _S =8.0A, V _{GS} =0V
		IRF441	—	—	2.0	V	T _C =25°C, I _S =8.0A, V _{GS} =0V
		IRF442	—	—	1.9	V	T _C =25°C, I _S =7.0A, V _{GS} =0V
Reverse Recovery Time	t _{rr}	ALL	—	1100	—	ns	T _J =150°C, I _F =8.0A, di _F /dt=100A/μs

Notes: (1) T_J=25°C to 150°C (2) Pulse test: Pulse width≤300μs, Duty Cycle≤2%
(3) Repetitive rating: Pulse width limited by max. junction temperature

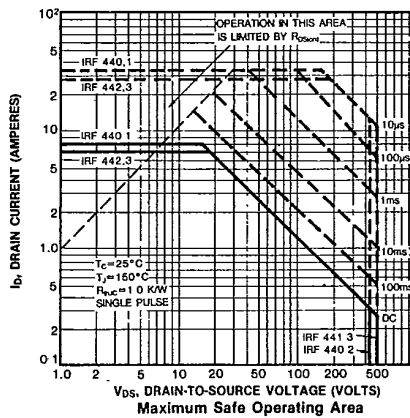
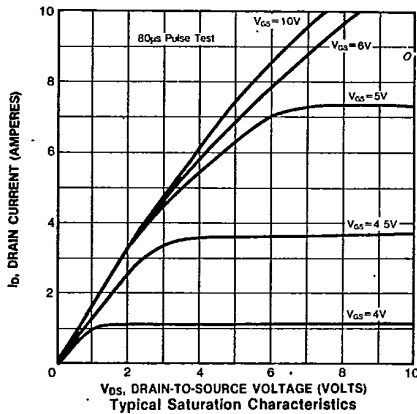
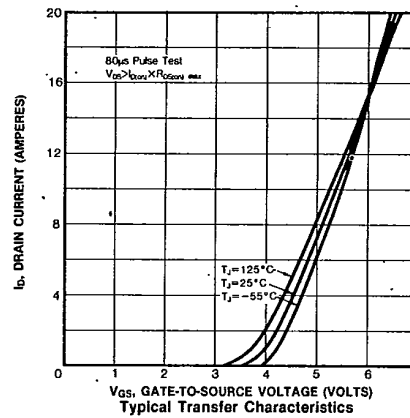
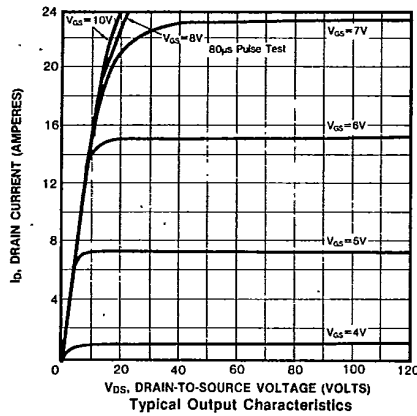

IRF440/441/442/443

N-CHANNEL
POWER MOSFETS

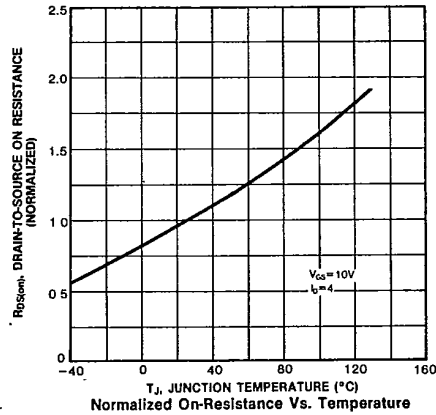
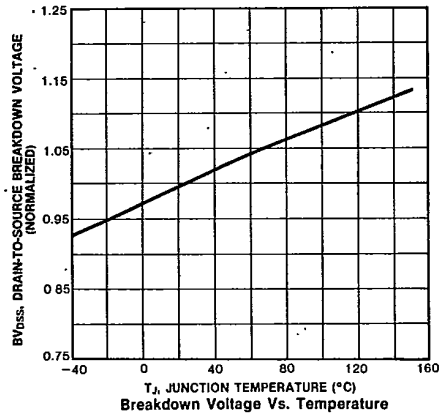
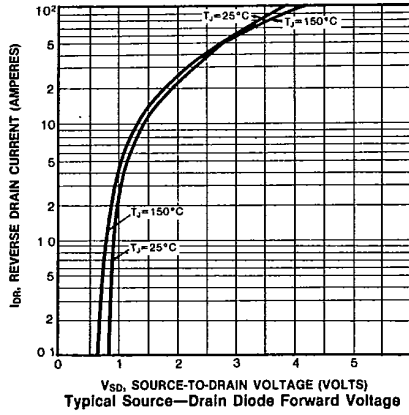
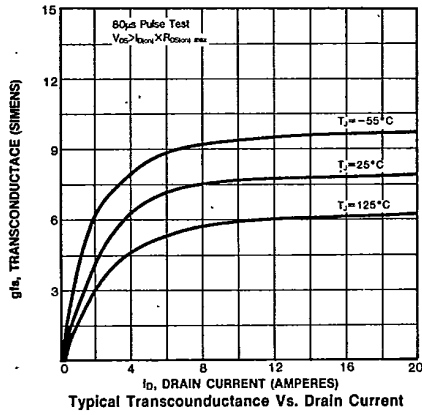
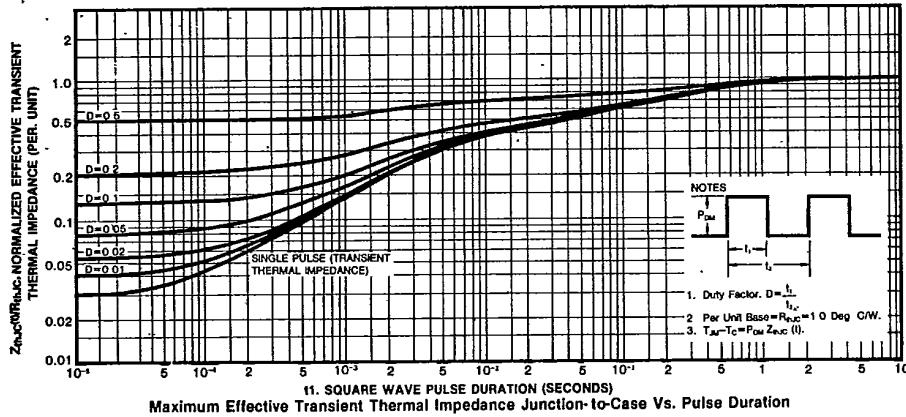

IRF440/441/442/443

**N-CHANNEL
POWER MOSFETS**

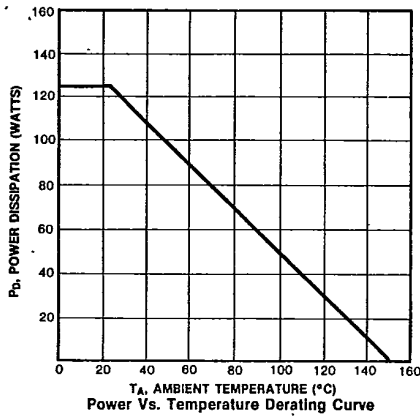
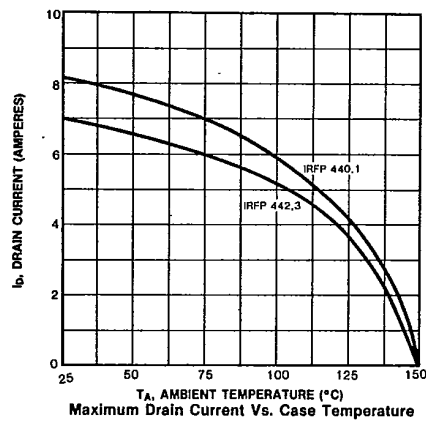
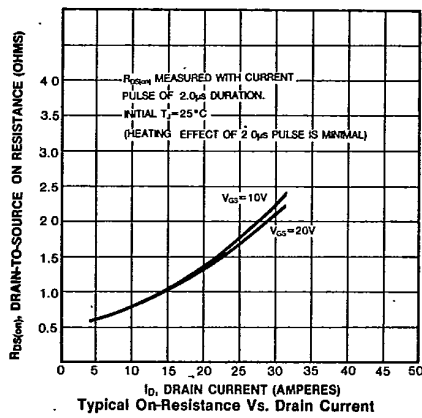
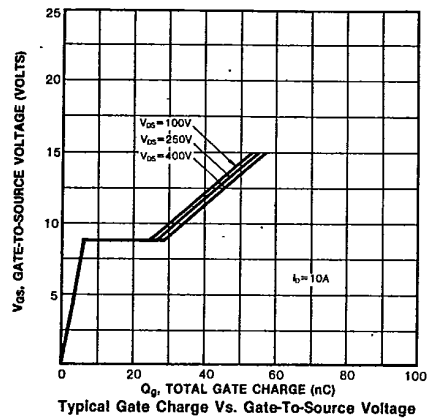
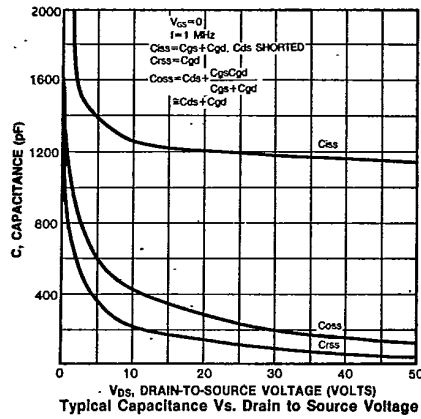

This datasheet has been downloaded from:

www.DatasheetCatalog.com

Datasheets for electronic components.



LittleDiode supplies new, hard to find or obsolete electronic components and semiconductors all over the world.

With over two million different components listed you are sure to find the part you need.

Feel free to visit us today at our online store:

LittleDiode.com

Looking forward to providing you with the best possible service.