

20V N-Channel Enhancement Mode MOSFET

■ Features

- Advanced trench process technology
- High density cell design for ultra low on-resistance
- Excellent thermal and electrical capabilities
- Compact and low profile SOT-23 package

■ Product Summary

$V_{DS} = 20V$
 $R_{DS(on)}, V_{GS}@4.5V, I_{DS}@3.6A} = 65m\Omega$
 $R_{DS(on)}, V_{GS}@2.5V, I_{DS}@3.1A} = 95m\Omega$

■ Pin Assignments

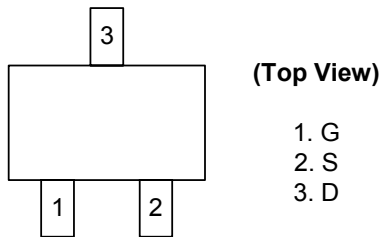

■ Pin Descriptions

Pin No.	Pin Name	Description
1	G	Gate
2	S	Source
3	D	Drain

■ Ordering information

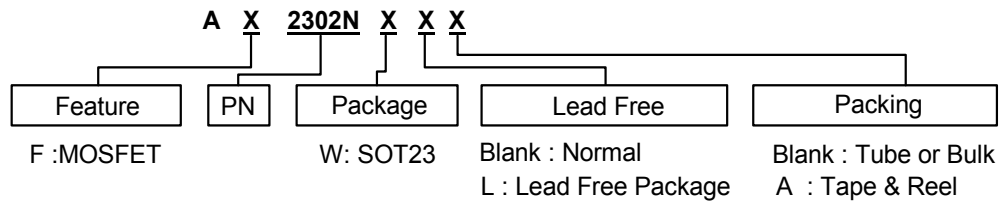

■ Block Diagram

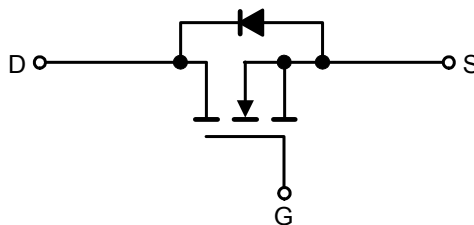



20V N-Channel Enhancement Mode MOSFET

■ Absolute Maximum Ratings ($T_A=25^\circ\text{C}$ unless otherwise noted)

Symbol	Parameter	Rating	Units
V_{DS}	Drain-Source Voltage	20	V
V_{GS}	Gate-Source Voltage	± 8	V
I_D	Continuous Drain Current	2.4	A
I_{DM}	Pulsed Drain Current	10	A
P_D	Maximum Power Dissipation	$T_A=25^\circ\text{C}$	1.25
		$T_A=70^\circ\text{C}$	0.8
T_J	Operating Junction Temperature	+150	$^\circ\text{C}$
T_J, T_{STG}	Operating Junction and Storage Temperature Range	-55 to +150	$^\circ\text{C}$

■ Thermal Performance

Symbol	Parameter	Limit	Units
T_L	Lead Temperature (1/8" from case)	5	S
$R_{\theta JA}$	Junction to Ambient Thermal Resistance (PCB mounted)	100	$^\circ\text{C/W}$

Note: Surface mounted on FR4 board $t \leq 5$ sec.

■ Electrical Characteristics Rate $I_D=2.4\text{A}$, ($T_A=25^\circ\text{C}$ unless otherwise noted)

Symbol	Parameter	Test Conditions	Limits			Unit
			Min.	Typ.	Max.	
Static						
BV_{DSS}	Drain-Source Breakdown Voltage	$V_{GS}=0\text{V}, I_D=250\mu\text{A}$	20	-	-	V
$R_{DS(ON)}$	Drain-Source On-State Resistance	$V_{GS}=4.5\text{V}, I_D=3.6\text{A}$	-	50	65	m Ω
		$V_{GS}=2.5\text{V}, I_D=3.1\text{A}$	-	75	95	
$V_{GS(TH)}$	Gate Threshold Voltage	$V_{DS}=V_{GS}, I_D=250\mu\text{A}$	0.45	-	-	V
I_{DSS}	Zero Gate Voltage Drain Current	$V_{DS}=20\text{V}, V_{GS}=0\text{V}$	-	-	1.0	μA
I_{GSS}	Gate Body Leakage	$V_{GS}=\pm 8\text{V}, V_{DS}=0\text{V}$	-	-	± 100	nA
$I_{D(ON)}$	On-State Drain Current	$V_{DS}=5\text{V}, V_{GS}=4.5\text{V}$	6	-	-	A
g_{fs}	Forward Transconductance	$V_{DS}=5\text{V}, I_D=3.6\text{A}$	-	10	-	S
Dynamic						
Q_g	Total Gate Charge	$V_{DS}=10\text{V}, I_D=3.6\text{A},$ $V_{GS}=4.5\text{V}$	-	5.2	10	nC
Q_{GS}	Gate-Source Charge		-	0.65	-	
Q_{GD}	Gate-Drain Charge		-	1.5	-	
$t_{d(on)}$	Turn-On Delay Time	$V_{DD}=10\text{V}, R_L=10\Omega,$ $I_D=1\text{A}, V_{GEN}=4.5\text{V},$ $R_G=6\Omega$	-	7	15	nS
t_r	Turn-On Rise Time		-	55	80	
$t_{d(off)}$	Turn-Off Delay Time		-	16	60	
t_f	Turn-Off Fall-Time		-	10	25	
C_{ISS}	Input Capacitance	$V_{DS}=10\text{V}, V_{GS}=0\text{V},$ $f=1.0\text{MHz}$	-	450	-	pF
C_{OSS}	Output Capacitance		-	70	-	
C_{RSS}	Reverse Transfer Capacitance		-	43	-	
Source-Drain Diode						
I_S	Max. Diode Forward Current		-	-	1.6	A
V_{SD}	Diode Forward Voltage	$I_S=1.0\text{A}, V_{GS}=0\text{V}$	-	0.75	1.2	V

Note: Pulse test: pulse width $\leq 300\mu\text{s}$, duty cycle $\leq 2\%$

20V N-Channel Enhancement Mode MOSFET

■ Typical Performance Characteristics ($T_a=25^\circ\text{C}$ unless otherwise noted)

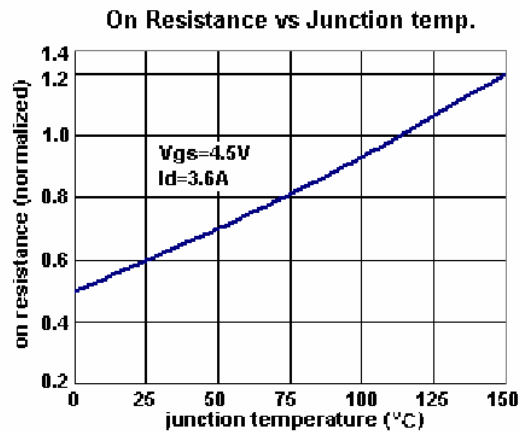
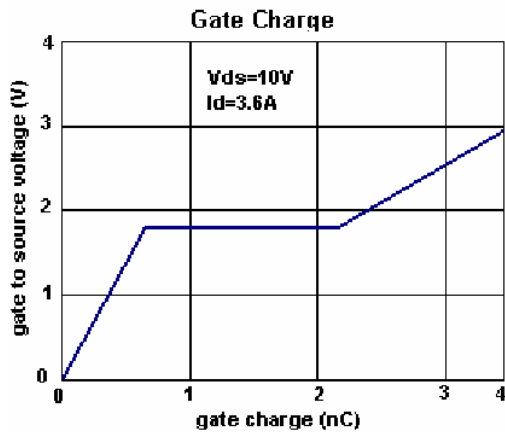
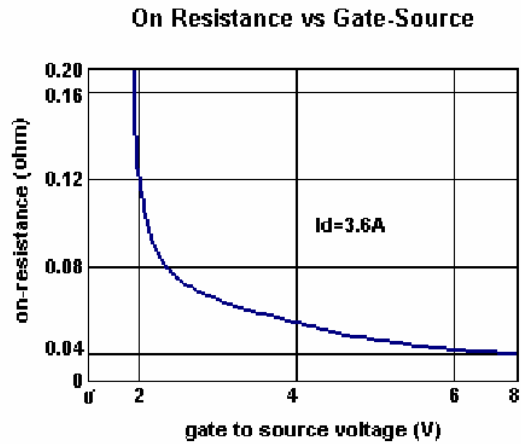
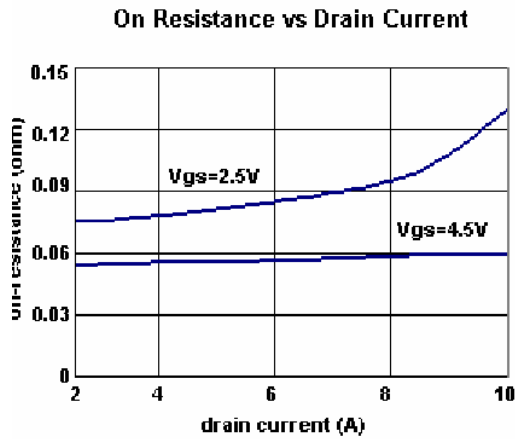
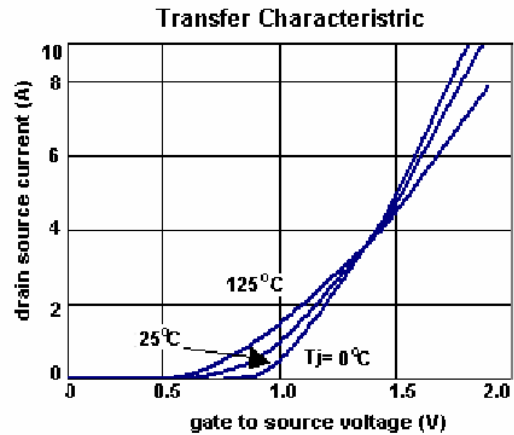
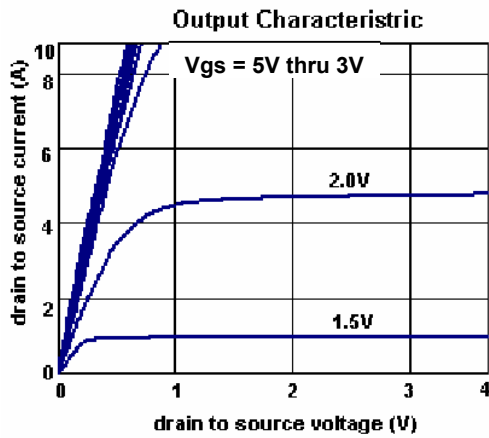

20V N-Channel Enhancement Mode MOSFET

■ Typical Performance Characteristics (Continued)

($T_a=25^\circ\text{C}$ unless otherwise noted)

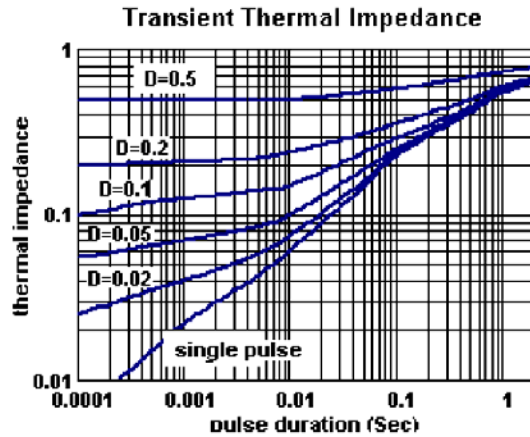
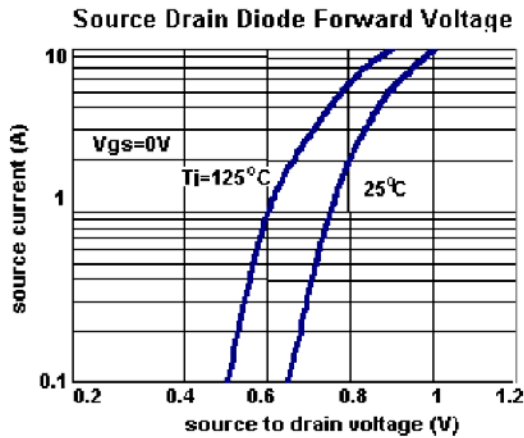

■ Switching Test Circuit

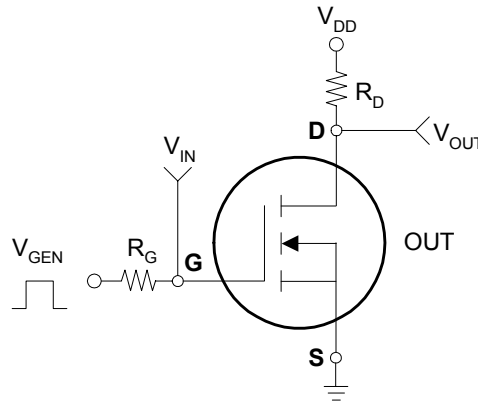

■ Switching Waveforms

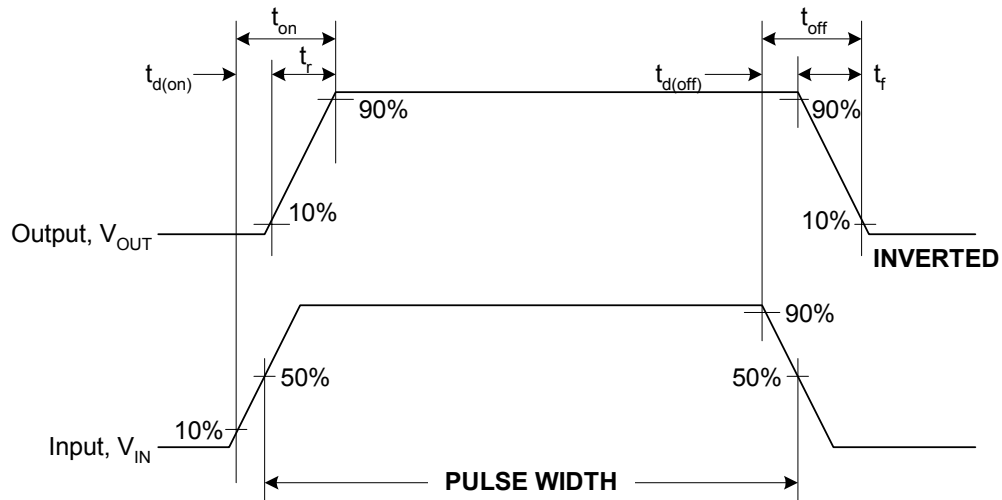

20V N-Channel Enhancement Mode MOSFET

■ Marking Information

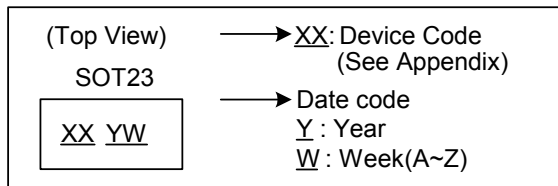

Appendix

Part Number	Package	Device Code
AF2302N	SOT23-3	02

■ Package Information

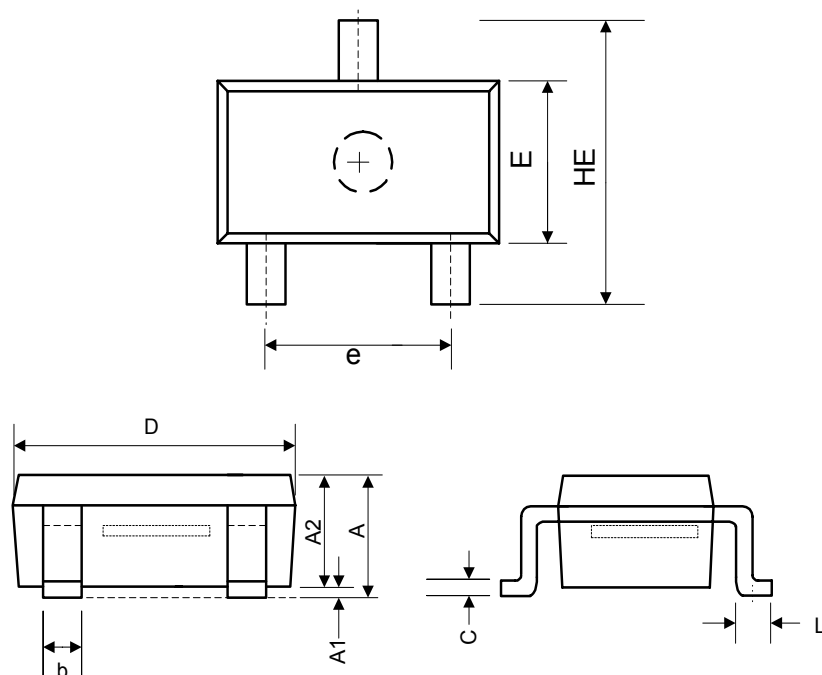

Symbol	Dimensions In Millimeters			Dimensions In Inches		
	Min.	Nom.	Max.	Min.	Nom.	Max.
A	1.00	1.20	1.40	0.039	0.047	0.055
A1	0.00	-	0.10	0.000	-	0.004
A2	1.00	1.15	1.30	0.039	0.045	0.051
b	0.35	-	0.50	0.014	-	0.020
C	0.10	0.175	0.25	0.004	0.007	0.010
D	2.70	2.90	3.10	0.106	0.114	0.122
E	1.40	1.60	1.80	0.055	0.063	0.071
e	1.70	2.00	2.30	0.067	0.079	0.091
HE	2.40	2.70	3.00	0.094	0.106	0.118
L	0.30	-	0.55	0.012	-	0.022



LittleDiode supplies new, hard to find or obsolete electronic components and semiconductors all over the world.

With over two million different components listed you are sure to find the part you need.

Feel free to visit us today at our online store:

LittleDiode.com

Looking forward to providing you with the best possible service.