



P-Channel Enhancement Mode Power MOSFET

■ Absolute Maximum Ratings

Symbol	Parameter	Rating	Units
V_{DS}	Drain-Source Voltage	-30	V
V_{GS}	Gate-Source Voltage	± 20	V
I_D	Continuous Drain Current (Note 1)	$T_A=25^\circ\text{C}$	-8
		$T_A=70^\circ\text{C}$	-6
I_{DM}	Pulsed Drain Current (Note 2)	-50	A
P_D	Total Power Dissipation	$T_A=25^\circ\text{C}$	2.5
	Linear Derating Factor		0.02
T_{STG}	Storage Temperature Range	-55 to 150	$^\circ\text{C}$
T_J	Operating Junction Temperature Range	-55 to 150	$^\circ\text{C}$

■ Thermal Data

Symbol	Parameter	Maximum	Units
Rthj-amb	Thermal Resistance Junction-ambient (Note 1) Max.	50	$^\circ\text{C}/\text{W}$

■ Electrical Characteristics at $T_J=25^\circ\text{C}$ unless otherwise specified

Symbol	Parameter	Test Conditions	Min.	Typ.	Max.	Units
BV_{DSS}	Drain-Source Breakdown Voltage	$V_{GS}=0\text{V}, I_D=-250\mu\text{A}$	-30	-	-	V
$\Delta BV_{DSS} / \Delta T_J$	Breakdown Voltage Temperature Coefficient	Reference to 25°C , $I_D=-1\text{mA}$	-	-0.037	-	$\text{V}/^\circ\text{C}$
$R_{DS(ON)}$	Static Drain-Source On-Resistance (Note 3)	$V_{GS}=-10\text{V}, I_D=-8\text{A}$	-	-	20	m Ω
		$V_{GS}=-4.5\text{V}, I_D=-5\text{A}$	-	-	35	
$V_{GS(th)}$	Gate Threshold Voltage	$V_{DS}=V_{GS}, I_D=-250\mu\text{A}$	-1	-	-3	V
g_{fs}	Forward Transconductance	$V_{DS}=-15\text{V}, I_D=-8\text{A}$	-	20	-	S
I_{DSS}	Drain-Source Leakage Current ($T_J=25^\circ\text{C}$)	$V_{DS}=-30\text{V}, V_{GS}=0\text{V}$	-	-	-1	μA
	Drain-Source Leakage Current ($T_J=70^\circ\text{C}$)	$V_{DS}=-24\text{V}, V_{GS}=0\text{V}$	-	-	-25	
I_{GSS}	Gate-Source Leakage	$V_{GS}=\pm 20\text{V}$	-	-	± 100	nA
Q_g	Total Gate Charge (Note 3)	$I_D=-4.6\text{A}$	-	36	-	nC
Q_{gs}	Gate-Source Charge	$V_{DS}=-15\text{V}$	-	5.5	-	
Q_{gd}	Gate-Drain ("Miller") Charge	$V_{GS}=-10\text{V}$	-	3.5	-	
$t_{d(on)}$	Turn-On Delay Time (Note 3)	$V_{DS}=-15\text{V}$	-	12	-	ns
t_r	Rise Time	$I_D=-1\text{A}$	-	8	-	
$t_{d(off)}$	Turn-Off Delay Time	$R_G=6\Omega, V_{GS}=-10\text{V}$	-	75	-	
t_f	Fall-Time	$R_D=15\Omega$	-	40	-	
C_{iss}	Input Capacitance	$V_{GS}=0\text{V}$	-	1530	-	pF
C_{oss}	Output Capacitance	$V_{DS}=-15\text{V}$	-	900	-	
C_{rss}	Reverse Transfer Capacitance	$f=1.0\text{MHz}$	-	280	-	

■ Source-Drain Diode

Symbol	Parameter	Test Conditions	Min.	Typ.	Max.	Unit
I_S	Continuous Source Current (Body Diode)	$V_D=V_G=0\text{V}, V_S=-1.2\text{V}$	-	-	-2.08	A
V_{SD}	Forward On Voltage (Note 3)	$T_J=25^\circ\text{C}, I_S=-2.1\text{A}, V_{GS}=0\text{V}$	-	-0.75	-1.2	V

Note 1: Surface mounted on 1 in² copper pad of FR4 board; 125 $^\circ\text{C}/\text{W}$ when mounted on Min. copper pad.

Note 2: Pulse width limited by Max. junction temperature.

Note 3: Pulse width $\leq 300\mu\text{s}$, duty cycle $\leq 2\%$.

P-Channel Enhancement Mode Power MOSFET

■ Typical Performance Characteristics

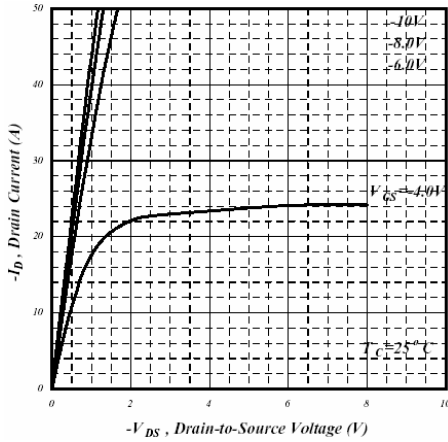

Fig 1. Typical Output Characteristics

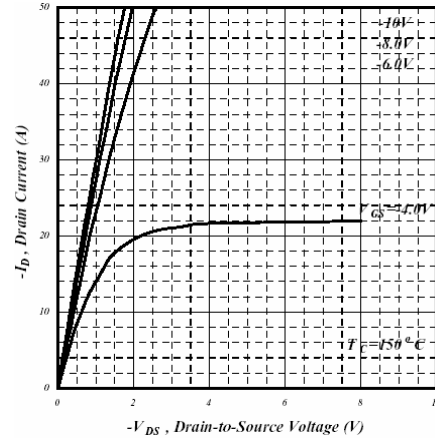

Fig 2. Typical Output Characteristics

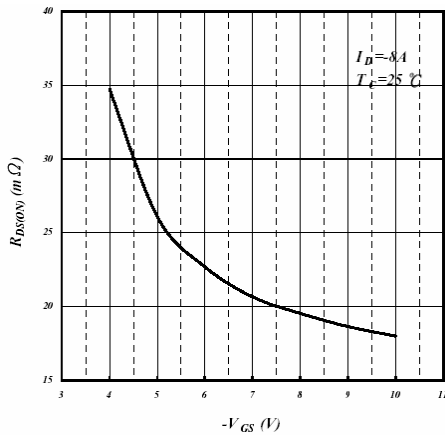

Fig 3. On-Resistance v.s. Gate Voltage

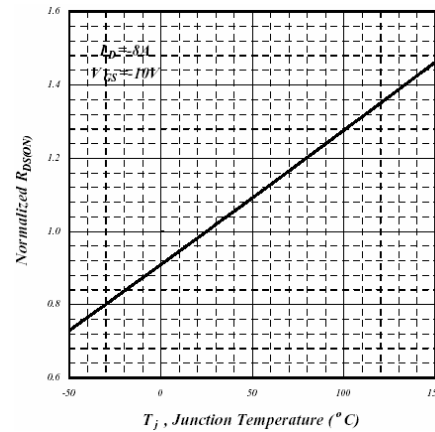

Fig 4. Normalized On-Resistance v.s. Junction Temperature

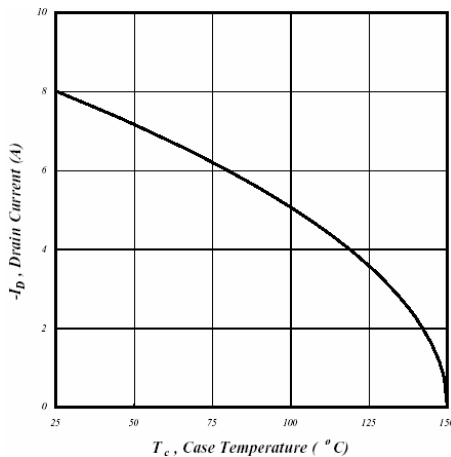

Fig 5. Maximum Drain Current v.s. Case Temperature

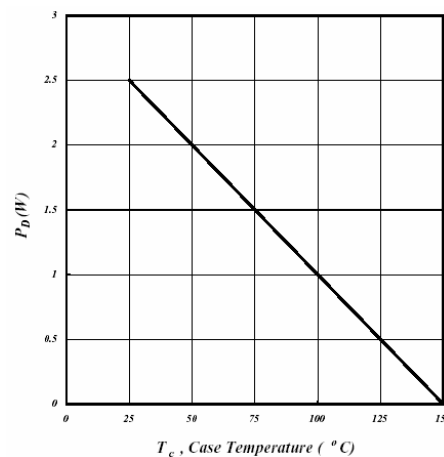

Fig 6. Typical Power Dissipation

P-Channel Enhancement Mode Power MOSFET

■ Typical Performance Characteristics (Continued)

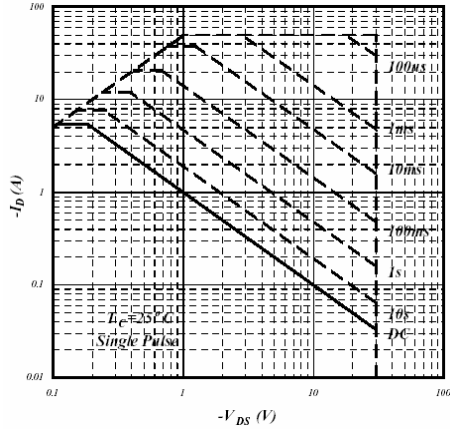

Fig 7. Maximum Safe Operating Area

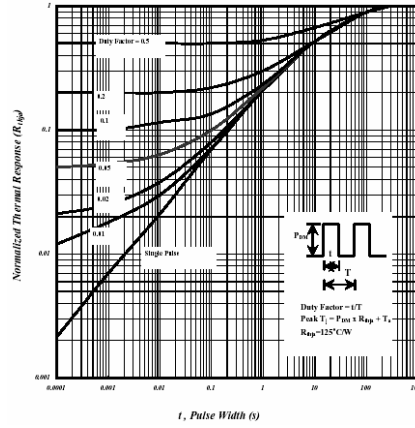

Fig 8. Effective Transient Thermal Impedance

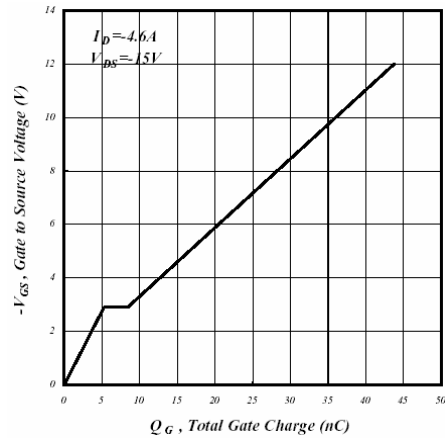

Fig 9. Gate Charge Characteristics

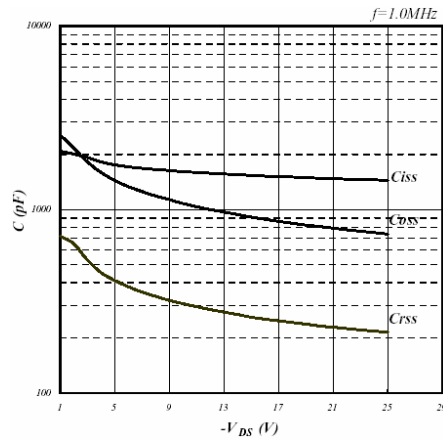

Fig 10. Typical Capacitance Characteristics

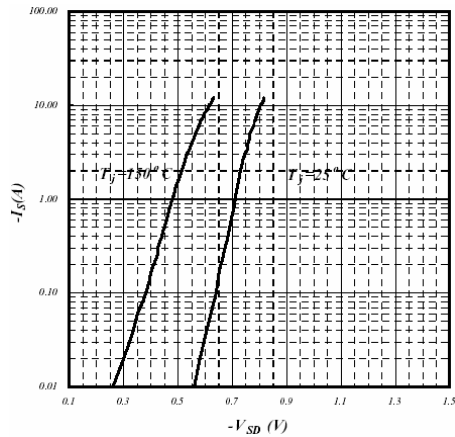

Fig 11. Forward Characteristic of Reverse Diode

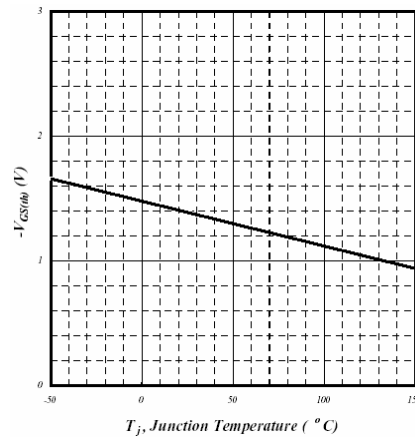

Fig 12. Gate Threshold Voltage v.s. Junction Temperature

P-Channel Enhancement Mode Power MOSFET

■ Typical Performance Characteristics (Continued)

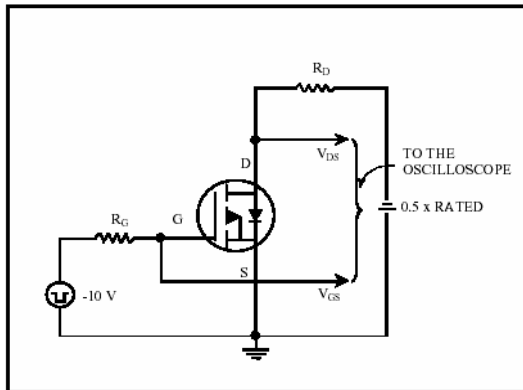

Fig 13. Switching Time Circuit

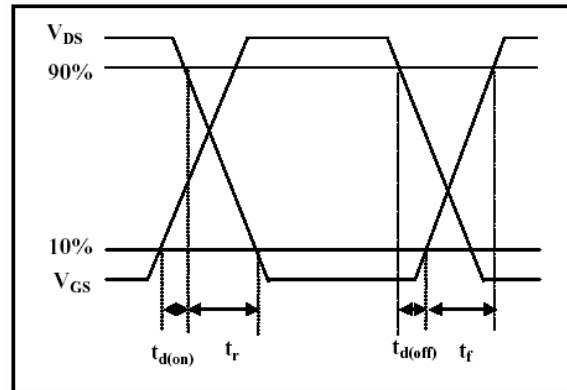

Fig 14. Switching Time Waveform

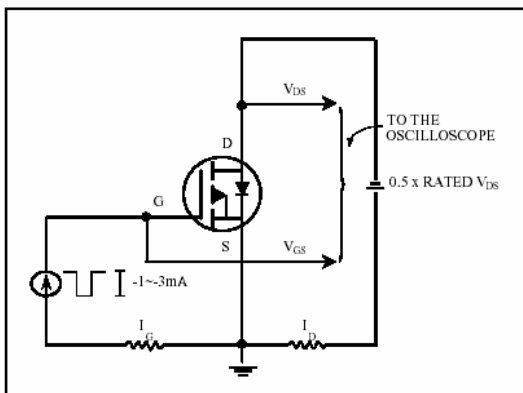

Fig 15. Gate Charge Circuit

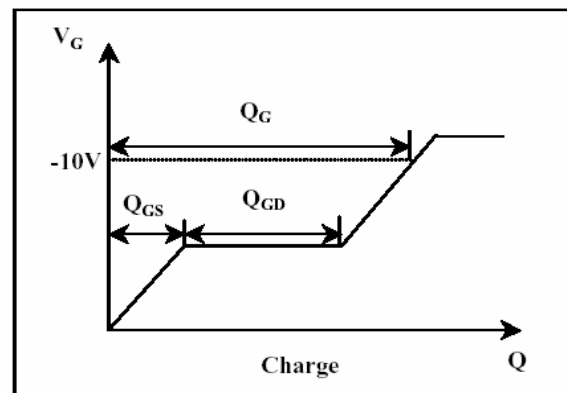
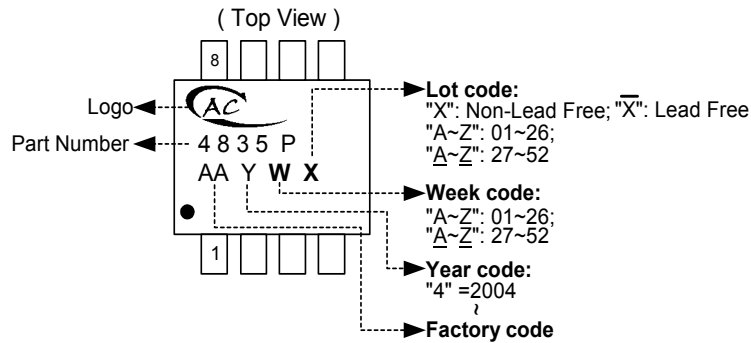

Fig 16. Gate Charge Waveform

P-Channel Enhancement Mode Power MOSFET

■ Marking Information

SOP-8L



■ Package Information

Package Type: SOP-8L

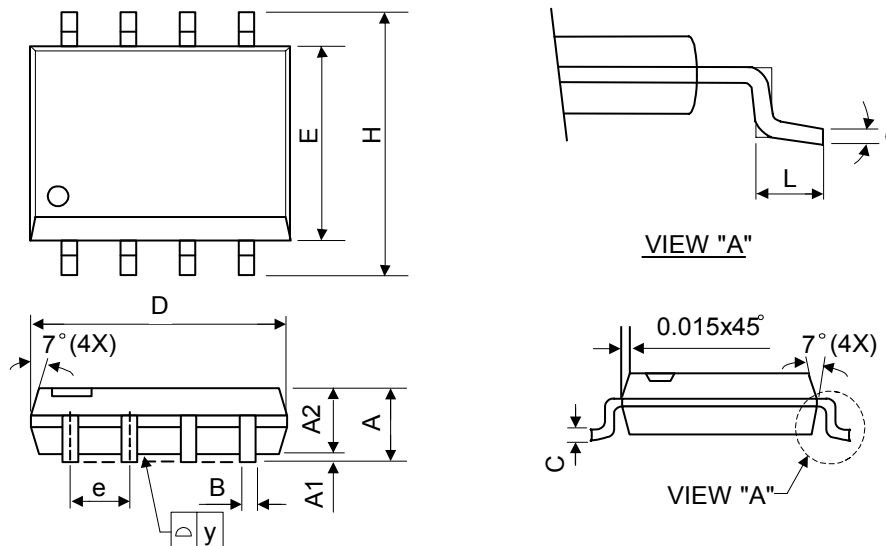

Symbol	Dimensions In Millimeters			Dimensions In Inches		
	Min.	Nom.	Max.	Min.	Nom.	Max.
A	1.40	1.60	1.75	0.055	0.063	0.069
A1	0.10	-	0.25	0.040	-	0.100
A2	1.30	1.45	1.50	0.051	0.057	0.059
B	0.33	0.41	0.51	0.013	0.016	0.020
C	0.19	0.20	0.25	0.0075	0.008	0.010
D	4.80	5.05	5.30	0.189	0.199	0.209
E	3.70	3.90	4.10	0.146	0.154	0.161
e	-	1.27	-	-	0.050	-
H	5.79	5.99	6.20	0.228	0.236	0.244
L	0.38	0.71	1.27	0.015	0.028	0.050
y	-	-	0.10	-	-	0.004
θ	0°	-	8°	0°	-	8°



LittleDiode supplies new, hard to find or obsolete electronic components and semiconductors all over the world.

With over two million different components listed you are sure to find the part you need.

Feel free to visit us today at our online store:

LittleDiode.com

Looking forward to providing you with the best possible service.