

### Features

- Epitaxial Planar Die Construction
- Complementary PNP Types Available (DDTA)
- Built-In Biasing Resistors
- Lead Free Device

### Mechanical Data

- Case: SOT-523, Molded Plastic
- Case material - UL Flammability Rating 94V-0
- Moisture sensitivity: Level 1 per J-STD-020A
- Terminals: Finish - Matte Tin (Note 1) Solderable per MIL-STD-202, Method 208
- Terminal Connections: See Diagram
- Marking: Date Code and Marking Code (See Diagrams & Page 2)
- Weight: 0.002 grams (approx.)
- Ordering Information (See Page 2)

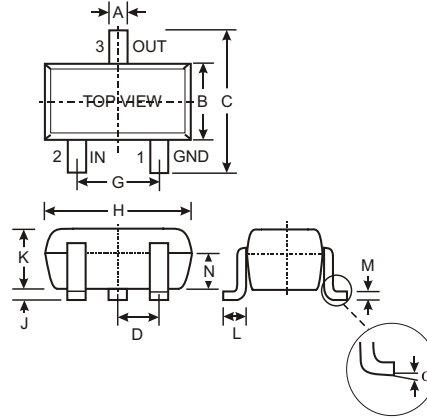

SOT-523			
Dim	Min	Max	Typ
A	0.15	0.30	0.22
B	0.75	0.85	0.80
C	1.45	1.75	1.60
D	—	—	0.50
G	0.90	1.10	1.00
H	1.50	1.70	1.60
J	0.00	0.10	0.05
K	0.60	0.80	0.75
L	0.10	0.30	0.22
M	0.10	0.20	0.12
N	0.45	0.65	0.50
$\alpha$	0°	8°	—
All Dimensions in mm			

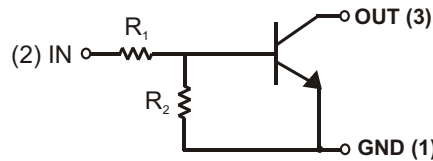

P/N	R1 (NOM)	R2 (NOM)	MARKING
DDTC122LE	0.22K $\Omega$	10K $\Omega$	N81
DDTC142JE	0.47K $\Omega$	10K $\Omega$	N82
DDTC122TE	0.22K $\Omega$	OPEN	N83
DDTC142TE	0.47K $\Omega$	OPEN	N84

### Maximum Ratings @ T<sub>A</sub> = 25°C unless otherwise specified

Characteristic	Symbol	Value	Unit
Supply Voltage, (3) to (1)	V <sub>CC</sub>	50	V
Input Voltage, (2) to (1)	V <sub>IN</sub>	-5 to +6	V
Input Voltage, (1) to (2)	V <sub>EBO (MAX)</sub>	5	V
Output Current	I <sub>C</sub>	100	mA
Power Dissipation (Note 2)	P <sub>d</sub>	150	mW
Thermal Resistance, Junction to Ambient Air (Note 2)	R <sub>θJA</sub>	625	°C/W
Operating and Storage and Temperature Range	T <sub>j</sub> , T <sub>STG</sub>	-55 to +150	°C

- Note: 1. If lead-bearing terminal plating is required, please contact your Diodes Inc. sales representative for availability and minimum order details.  
 2. Mounted on FR4 PC Board with recommended pad layout at <http://www.diodes.com/datasheets/ap02001.pdf>.

**Electrical Characteristics** @ T<sub>A</sub> = 25°C unless otherwise specified

**R1, R2 Types**

Characteristic		Symbol	Min	Typ	Max	Unit	Test Condition
Input Voltage	DDTC122LE DDTC142JE	V <sub>I(off)</sub>	0.3 0.3	—	—	V	V <sub>CC</sub> = 5V, I <sub>O</sub> = 100μA
	DDTC122LE DDTC142JE	V <sub>I(on)</sub>	—	—	2.0 2.0	V	V <sub>O</sub> = 0.3V, I <sub>O</sub> = 20mA V <sub>O</sub> = 0.3V, I <sub>O</sub> = 20mA
Output Voltage		V <sub>O(on)</sub>	—	—	0.3V	V	I <sub>O</sub> /I <sub>I</sub> = 5mA/0.25mA
Input Current	DDTC122LE DDTC142JE	I <sub>I</sub>	—	—	28 13	mA	V <sub>I</sub> = 5V
Output Current		I <sub>O(off)</sub>	—	—	0.5	μA	V <sub>CC</sub> = 50V, V <sub>I</sub> = 0V
DC Current Gain	DDTC122LE DDTC142JE	G <sub>I</sub>	56 56	—	—	—	V <sub>O</sub> = 5V, I <sub>O</sub> = 10mA
Gain-Bandwidth Product*		f <sub>T</sub>	—	200	—	MHz	V <sub>CE</sub> = 10V, I <sub>E</sub> = 5mA, f = 100MHz

\* Transistor - For Reference Only

**Electrical Characteristics** @ T<sub>A</sub> = 25°C unless otherwise specified

**R1-Only**

Characteristic		Symbol	Min	Typ	Max	Unit	Test Condition
Collector-Base Breakdown Voltage		BV <sub>CBO</sub>	50	—	—	V	I <sub>C</sub> = 50μA
Collector-Emitter Breakdown Voltage		BV <sub>CEO</sub>	40	—	—	V	I <sub>C</sub> = 1mA
Emitter-Base Breakdown Voltage	DDTC122TE DDTC142TE	BV <sub>EBO</sub>	5	—	—	V	I <sub>E</sub> = 50μA I <sub>E</sub> = 50μA
Collector Cutoff Current		I <sub>CBO</sub>	—	—	0.5	μA	V <sub>CB</sub> = 50V
Emitter Cutoff Current	DDTC122TE DDTC142TE	I <sub>EBO</sub>	—	—	0.5 0.5	μA	V <sub>EB</sub> = 4V
Collector-Emitter Saturation Voltage		V <sub>CE(sat)</sub>	—	—	0.3	V	I <sub>C</sub> = 5mA, I <sub>B</sub> = 0.25mA
DC Current Transfer Ratio	DDTC122TE DDTC142TE	h <sub>FE</sub>	100 100	250 250	600 600	—	I <sub>C</sub> = 1mA, V <sub>CE</sub> = 5V
Gain-Bandwidth Product*		f <sub>T</sub>	—	200	—	MHz	V <sub>CE</sub> = 10V, I <sub>E</sub> = -5mA, f = 100MHz

\* Transistor - For Reference Only

**Ordering Information** (Note 3)

Device	Packaging	Shipping
DDTC122LE-7	SOT-523	3000/Tape & Reel
DDTC142JE-7	SOT-523	3000/Tape & Reel
DDTC122TE-7	SOT-523	3000/Tape & Reel
DDTC142TE-7	SOT-523	3000/Tape & Reel

Notes: 1. If lead-bearing terminal plating is required, please contact your Diodes Inc. sales representative for availability and minimum order details.

3. For Packaging Details, go to our website at <http://www.diodes.com/datasheets/ap02007.pdf>.

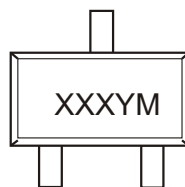
**Marking Information**

XXX = Product Type Marking Code (See Page 1)  
 YM = Date Code Marking  
 Y = Year ex: P = 2003  
 M = Month ex: 9 = September

Date Code Key

Year	2002	2003	2004	2005	2006	2007	2008	2009
Code	N	P	R	S	T	U	V	W

Month	Jan	Feb	March	Apr	May	Jun	Jul	Aug	Sep	Oct	Nov	Dec
Code	1	2	3	4	5	6	7	8	9	O	N	D

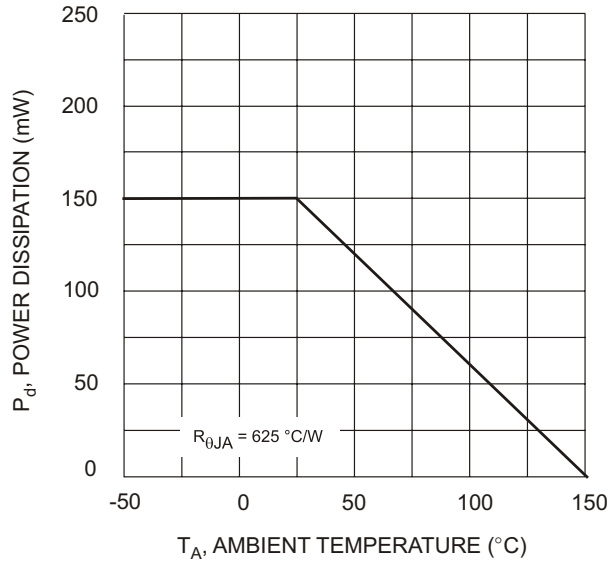

Fig. 1 Power Derating Curve



LittleDiode supplies new, hard to find or obsolete electronic components and semiconductors all over the world.

With over two million different components listed you are sure to find the part you need.

Feel free to visit us today at our online store:

[LittleDiode.com](http://LittleDiode.com)

Looking forward to providing you with the best possible service.