

Features

- Epitaxial Planar Die Construction
- Complementary NPN Types Available (DDTC)
- Built-In Biasing Resistors, R1 = R2
- Also Available in Lead Free Version

Mechanical Data

- Case: SOT-23, Molded Plastic
- Case material - UL Flammability Rating 94V-0
- Moisture sensitivity: Level 1 per J-STD-020A
- Terminals: Solderable per MIL-STD-202, Method 208
- Also Available in Lead Free Plating (Matte Tin Finish). Please see Ordering Information, Note 3, on Page 2
- Marking: Date Code and Marking Code (See Diagrams & Page 2)
- Terminal Connections: See Diagram
- Weight: 0.008 grams (approx.)
- Ordering Information (See Page 2)

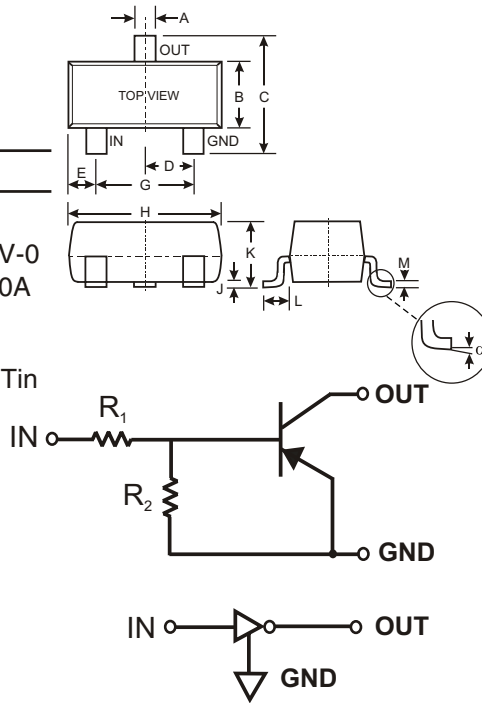

SOT-23		
Dim	Min	Max
A	0.37	0.51
B	1.20	1.40
C	2.30	2.50
D	0.89	1.03
E	0.45	0.60
G	1.78	2.05
H	2.80	3.00
J	0.013	0.10
K	0.903	1.10
L	0.45	0.61
M	0.85	0.80
α	0°	8°
All Dimensions in mm		

P/N	R1, R2 (NOM)	MARKING
DDTA123ECA	2.2K Ω	P04
DDTA143ECA	4.7K Ω	P08
DDTA114ECA	10K Ω	P13
DDTA124ECA	22K Ω	P17
DDTA144ECA	47K Ω	P20
DDTA115ECA	100K Ω	P24

SCHEMATIC DIAGRAM

Maximum Ratings @ T_A = 25°C unless otherwise specified

Characteristic	Symbol	Value	Unit
Supply Voltage, (3) to (1)	V _{CC}	-50	V
Input Voltage, (2) to (1)	V _{IN}	+10 to -12 +10 to -30 +10 to -40 +10 to -40 +10 to -40 +10 to -40	V
Output Current	I _O	-100 -100 -50 -30 -30 -20	mA
Output Current	I _C (Max)	-100	mA
Power Dissipation	P _d	200	mW
Thermal Resistance, Junction to Ambient Air (Note 1)	R _{θJA}	625	°C/W
Operating and Storage and Temperature Range	T _J , T _{STG}	-55 to +150	°C

Note: 1. Mounted on FR4 PC Board with recommended pad layout at <http://www.diodes.com/datasheets/ap02001.pdf>.

Electrical Characteristics @ $T_A = 25^\circ\text{C}$ unless otherwise specified

Characteristic		Symbol	Min	Typ	Max	Unit	Test Condition
Input Voltage		$V_{I(off)}$	-0.5	-1.1	—	V	$V_{CC} = 5V, I_O = 100\mu A$
		$V_{I(on)}$	—	-1.9	-3		$V_O = 0.3V, I_O = 20mA, DDTA123ECA$ $V_O = 0.3V, I_O = 20mA, DDTA143ECA$ $V_O = 0.3V, I_O = 10mA, DDTA114ECA$ $V_O = 0.3V, I_O = 5mA, DDTA124ECA$ $V_O = 0.3V, I_O = 2mA, DDTA144ECA$ $V_O = 0.3V, I_O = 1mA, DDTA115ECA$
Output Voltage		$V_{O(on)}$	—	-0.1	-0.3	V	$I_O/I_I = 10mA/0.5mA, DDTA123ECA$ $I_O/I_I = 10mA/0.5mA, DDTA143ECA$ $I_O/I_I = 10mA/0.5mA, DDTA114ECA$ $I_O/I_I = 10mA/0.5mA, DDTA124ECA$ $I_O/I_I = 10mA/0.5mA, DDTA144ECA$ $I_O/I_I = 5mA/0.25mA, DDTA115ECA$
Input Current	DDTA123ECA DDTA143ECA DDTA114ECA DDTA124ECA DDTA144ECA DDTA115ECA	I_I	—	—	-3.8 -1.8 -0.88 -0.36 -0.18 -0.15	mA	$V_I = -5V$
Output Current		$I_{O(off)}$	—	—	0.5	μA	$V_{CC} = -50V, V_I = 0V$
DC Current Gain	DDTA123ECA DDTA143ECA DDTA114ECA DDTA124ECA DDTA144ECA DDTA115ECA	G_I	-20 -20 -30 -56 -68 -82	—	—	—	$V_O = -5V, I_O = -20mA$ $V_O = -5V, I_O = -10mA$ $V_O = -5V, I_O = -5mA$ $V_O = -5V, I_O = -5mA$ $V_O = -5V, I_O = -5mA$ $V_O = -5V, I_O = -5mA$
Input Resistor (R_1) Tolerance		ΔR_1	-30	—	+30	%	—
Resistance Ratio		R_2/R_1	0.8	1	1.2	—	—
Gain-Bandwidth Product*		f_T	—	250	—	MHz	$V_{CE} = -10V, I_E = 5mA, f = 100MHz$

* Transistor - For Reference Only

Ordering Information (Note 2)

Device	Packaging	Shipping
DDTA123ECA-7	SOT-23	3000/Tape & Reel
DDTA143ECA-7	SOT-23	3000/Tape & Reel
DDTA114ECA-7	SOT-23	3000/Tape & Reel
DDTA124ECA-7	SOT-23	3000/Tape & Reel
DDTA144ECA-7	SOT-23	3000/Tape & Reel
DDTA115ECA-7	SOT-23	3000/Tape & Reel

- Notes: 2. For Packaging Details, go to our website at <http://www.diodes.com/datasheets/ap02007.pdf>.
3. For Lead Free version (with Lead Free terminal finish) part number, please add "-F" suffix to part number above.
Example: DDTA115ECA-7-F.

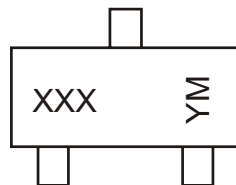
Marking Information

XXX = Product Type Marking Code
See Sheet 1 Diagrams
YM = Date Code Marking
Y = Year ex: N = 2002
M = Month ex: 9 = September

Date Code Key

Year	2002	2003	2004	2005	2006	2007	2008	2009
Code	N	P	R	S	T	U	V	W

Month	Jan	Feb	March	Apr	May	Jun	Jul	Aug	Sep	Oct	Nov	Dec
Code	1	2	3	4	5	6	7	8	9	O	N	D

TYPICAL CURVES - DDTA143ECA

NEW PRODUCT

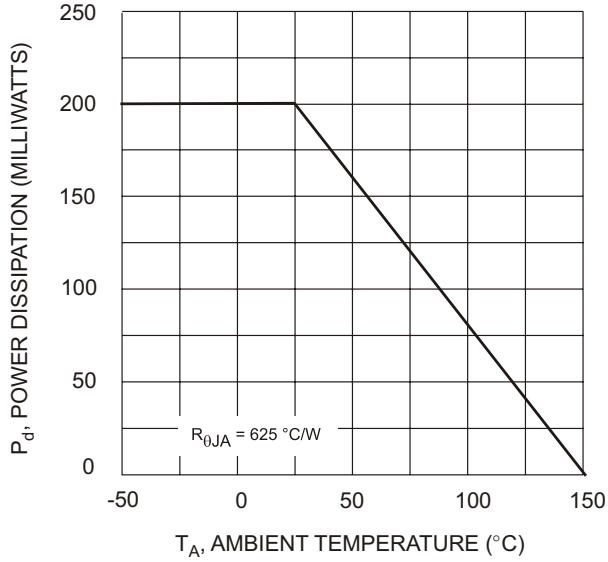

Fig. 1 Derating Curve

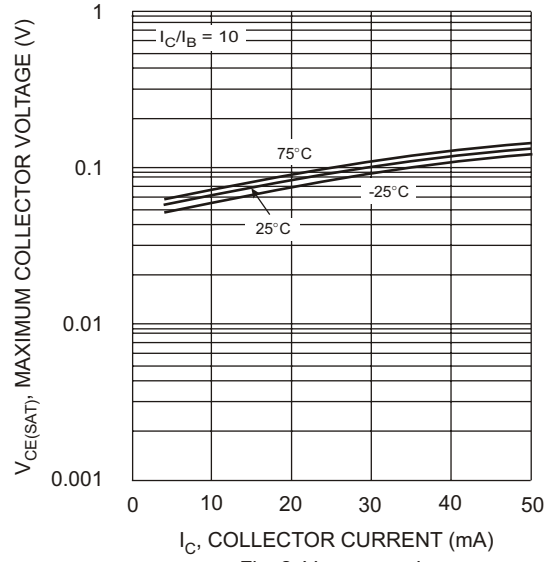

Fig. 2 $V_{CE(SAT)}$ vs. I_C

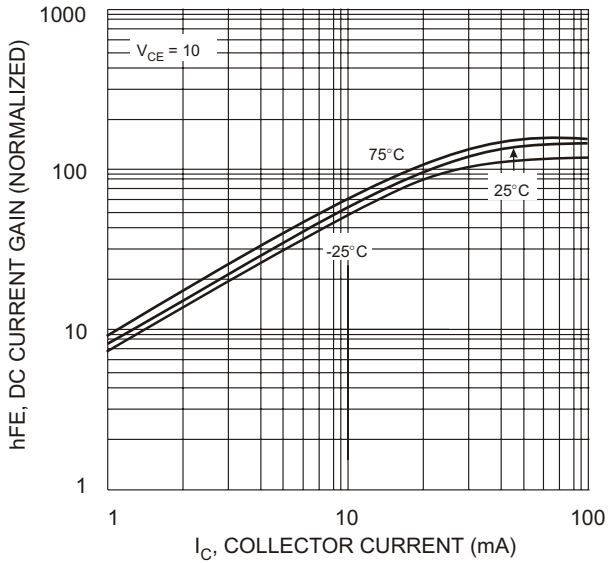

Fig. 3 DC CURRENT GAIN

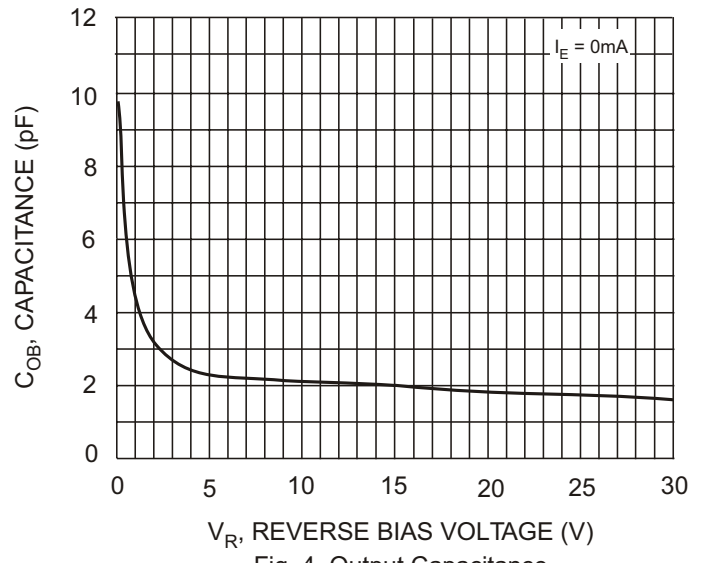

Fig. 4 Output Capacitance

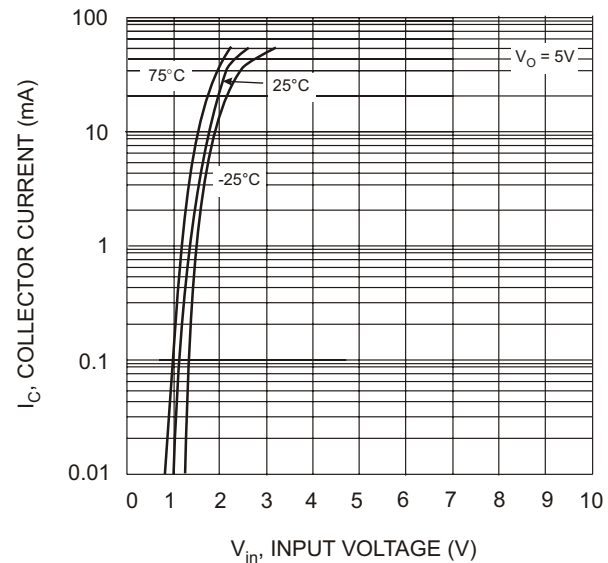

Fig. 5 Collector Current Vs. Input Voltage

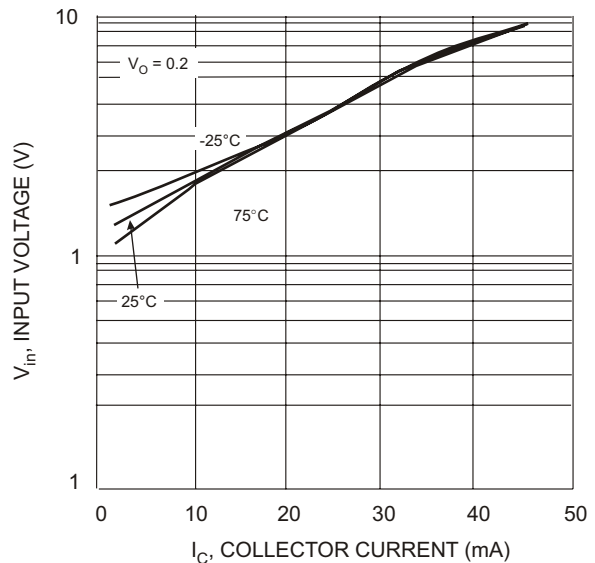

Fig. 6 Input Voltage vs. Collector Current



LittleDiode supplies new, hard to find or obsolete electronic components and semiconductors all over the world.

With over two million different components listed you are sure to find the part you need.

Feel free to visit us today at our online store:

LittleDiode.com

Looking forward to providing you with the best possible service.