

# FDP5800

## N-Channel Logic Level PowerTrench® MOSFET

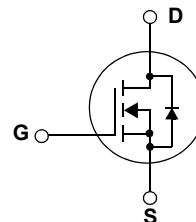
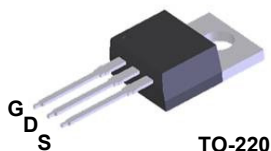
60V ,80 A, 6 mΩ

### Features

- $R_{DS(on)} = 4.6 \text{ m}\Omega$  (Typ.),  $V_{GS} = 10 \text{ V}$ ,  $I_D = 80 \text{ A}$
- High Performance Trench Technology for Externly Low  $R_{DS(on)}$
- Low Gate Charge
- High Power and Current Handling Capability
- RoHs Compliant

### Applications

- Power tools
- Motor drives and Uninterruptible Power Supplies
- Synchronous Rectification
- Battery Protection Circuit



### MOSFET Maximum Ratings $T_C = 25^\circ\text{C}$ unless otherwise noted\*

Symbol	Parameter	FDP5800	Unit
$V_{DSS}$	Drain-Source Voltage	60	V
$V_{GSS}$	Gate-Source Voltage	$\pm 20$	V
$I_D$	Drain Current	-Continuous ( $T_C = 25^\circ\text{C}$ )	80
		-Continuous ( $T_C = 100^\circ\text{C}$ )	80*
		-Continuous ( $T_A = 25^\circ\text{C}$ )	14
$I_{DM}$	Drain Current - Pulsed	320	A
$E_{AS}$	Single Pulsed Avalanche Energy (Note 1)	652	mJ
$P_D$	Power Dissipation ( $T_C = 25^\circ\text{C}$ ) - Derate above $25^\circ\text{C}$	242	W
		1.61	W/ $^\circ\text{C}$
$T_J, T_{STG}$	Operating and Storage Temperature Range	-55 to +175	$^\circ\text{C}$

\*Drain current limited by package

### Thermal Characteristics

$R_{\theta JC}$	Thermal Resistance , Junction to Case, Max.	0.62	$^\circ\text{C/W}$
$R_{\theta JA}$	Thermal Resistance , Junction to Ambient, Max.	62.5	$^\circ\text{C/W}$

### Package Marking and Ordering Information

Device Marking	Device	Package	Reel Size	Tape Width	Quantity
FDP5800	FDP5800	TO220	--	--	50

### Electrical Characteristics $T_C = 25^\circ\text{C}$ unless otherwise noted

Symbol	Parameter	Conditions	Min	Typ	Max	Unit
--------	-----------	------------	-----	-----	-----	------

#### Off Characteristics

$B_{VDSS}$	Drain-Source Breakdown Voltage	$I_D = 250\mu\text{A}$ , $V_{GS} = 0\text{V}$ , $T_J = 25^\circ\text{C}$	60	--	--	V
$I_{DSS}$	Zero Gate Voltage Drain Current	$V_{DS} = 48\text{V}$ $V_{GS} = 0\text{V}$ $T_J = 150^\circ\text{C}$	--	--	1	$\mu\text{A}$
$I_{GSS}$	Gate-Body Leakage Current, Forward	$V_{GS} = \pm 20\text{V}$ , $V_{DS} = 0\text{V}$	--	--	$\pm 100$	nA

#### On Characteristics

$V_{GS(th)}$	Gate Threshold Voltage	$V_{GS} = V_{DS}$ , $I_D = 250\mu\text{A}$	1.0	--	2.5	V
$R_{DS(on)}$	Static Drain-Source On Resistance	$V_{GS} = 10\text{V}$ , $I_D = 80\text{A}$	--	4.6	6.0	m $\Omega$
		$V_{GS} = 4.5\text{V}$ , $I_D = 80\text{A}$	--	5.9	7.2	m $\Omega$
		$V_{GS} = 5\text{V}$ , $I_D = 80\text{A}$	--	5.6	7.0	m $\Omega$
		$V_{GS} = 10\text{V}$ , $I_D = 80\text{A}$ $T_J = 175^\circ\text{C}$	--	10.4	12.6	m $\Omega$

#### Dynamic Characteristics

$C_{iss}$	Input Capacitance	$V_{DS} = 15\text{V}$ , $V_{GS} = 0\text{V}$ $f = 1\text{MHz}$	--	6890	9160	pF	
$C_{oss}$	Output Capacitance		--	750	1000	pF	
$C_{rss}$	Reverse Transfer Capacitance		--	295	445	pF	
$R_G$	Gate Resistance	$V_{GS} = 0.5\text{V}$ , $f = 1\text{MHz}$	--	1.2	--	$\Omega$	
$Q_{g(TOT)}$	Total Gate Charge at 10V	$V_{GS} = 0\text{V}$ to 10V	$V_{DS} = 30\text{V}$ $I_D = 80\text{A}$ $I_g = 1\text{mA}$	--	112	145	nC
$Q_{g(TH)}$	Total Gate Charge at 5V	$V_{GS} = 0\text{V}$ to 5V		--	58	--	nC
$Q_{g(TH)}$	Threshold Gate Charge	$V_{GS} = 0\text{V}$ to 1V		--	7.0	--	nC
$Q_{gs}$	Gate to Source Gate Charge			--	23	--	nC
$Q_{gs2}$	Gate Charge Threshold to Plateau			--	13	--	nC
$Q_{gd}$	Gate to Drain "Miller" Charge			--	18	--	nC

#### Switching Characteristics ( $V_{GS} = 10\text{V}$ )

$t_{ON}$	Turn-On Time	$V_{DD} = 30\text{V}$ , $I_D = 80\text{A}$ $V_{GS} = 10\text{V}$ , $R_{GEN} = 1.5\Omega$	--	37	85	ns
$t_{d(on)}$	Turn-On Delay Time		--	18	46	ns
$t_r$	Turn-On Rise Time		--	19	47	ns
$t_{d(off)}$	Turn-Off Delay Time		--	55	120	ns
$t_f$	Turn-Off Fall Time		--	9	28	ns
$t_{OFF}$	Turn-Off Time		--	64	138	ns

#### Drain-Source Diode Characteristics

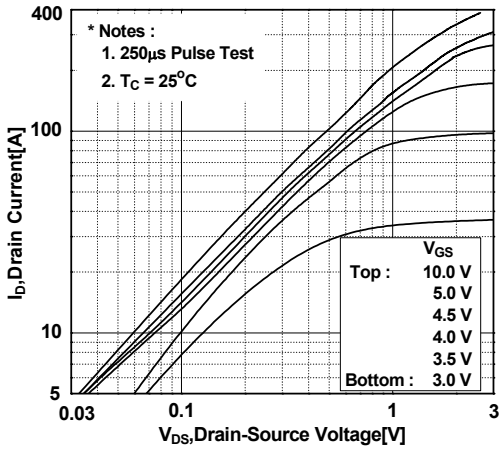
$V_{SD}$	Drain-Source Diode Forward Voltage	$V_{GS} = 0\text{V}$ , $I_{SD} = 80\text{A}$	--	--	1.25	V
		$V_{GS} = 0\text{V}$ , $I_{SD} = 40\text{A}$	--	--	1.0	V
$t_{rr}$	Reverse Recovery Time	$V_{GS} = 0\text{V}$ , $I_{SD} = 60\text{A}$	--	58	--	ns
$Q_{rr}$	Reverse Recovery Charge	$di_f/dt = 100\text{A}/\mu\text{s}$	--	106	--	nC

**Notes:**

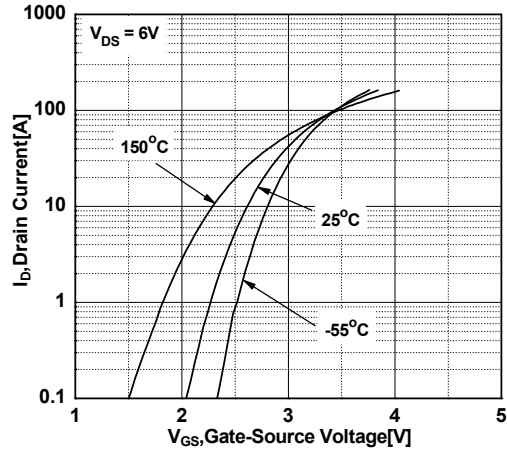
1:  $L = 1\text{mH}$ ,  $I_{AS} = 36\text{A}$ ,  $V_{DD} = 54\text{V}$ ,  $V_{GS} = 10\text{V}$ ,  $R_G = 25\Omega$ , Starting  $T_J = 25^\circ\text{C}$

## Typical Performance Characteristics

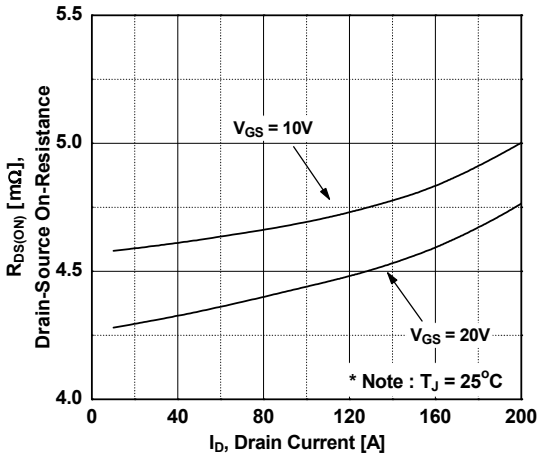
**Figure 1. On-Region Characteristics**



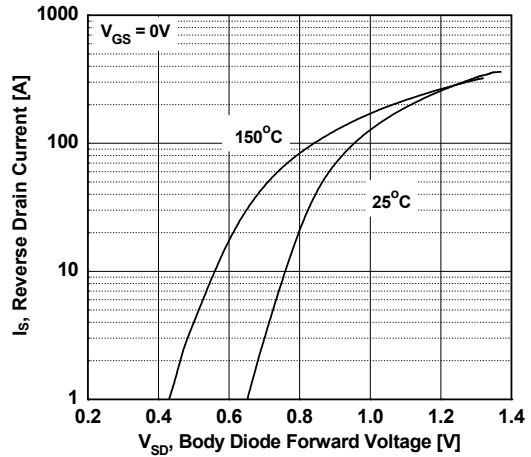
**Figure 2. Transfer Characteristics**



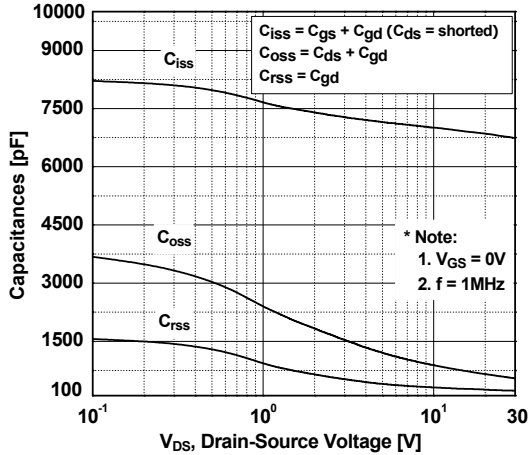
**Figure 3. On-Resistance Variation vs. Drain Current and Gate Voltage**



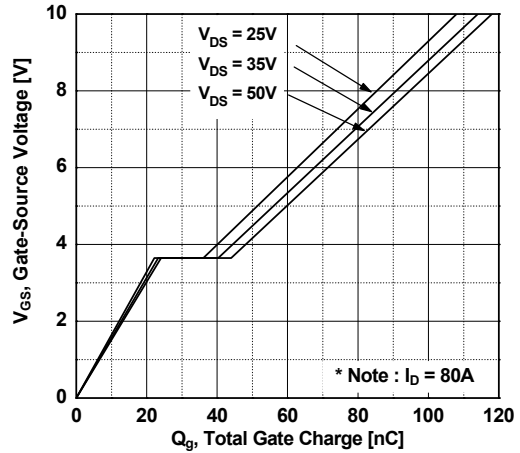
**Figure 4. Body Diode Forward Voltage Variation vs. Source Current and Temperature**



**Figure 5. Capacitance Characteristics**

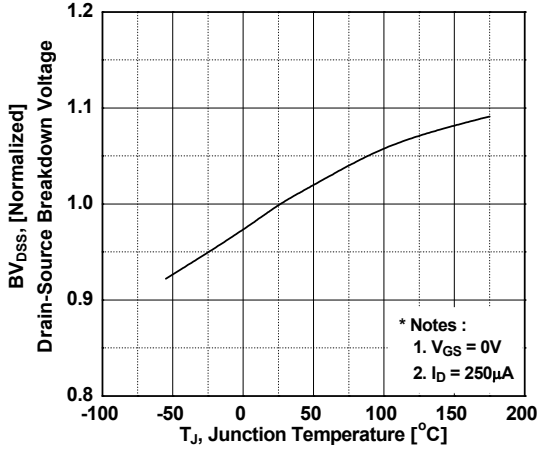


**Figure 6. Gate Charge Characteristics**

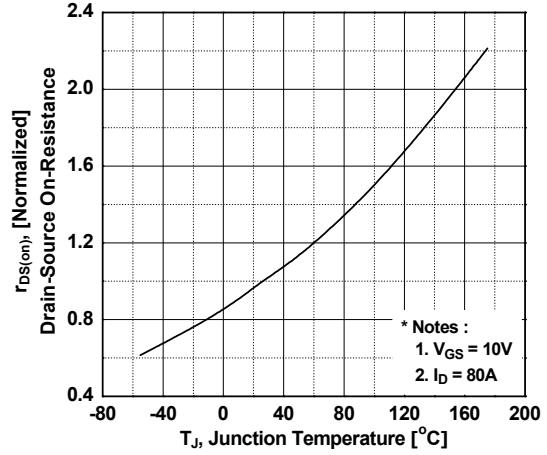


**Typical Performance Characteristics (Continued)**

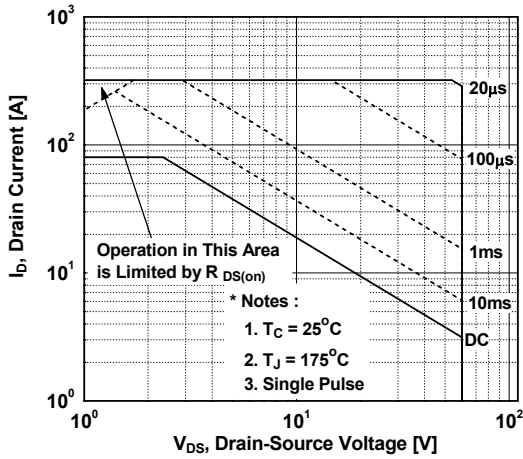
**Figure 7. Breakdown Voltage Variation vs. Temperature**



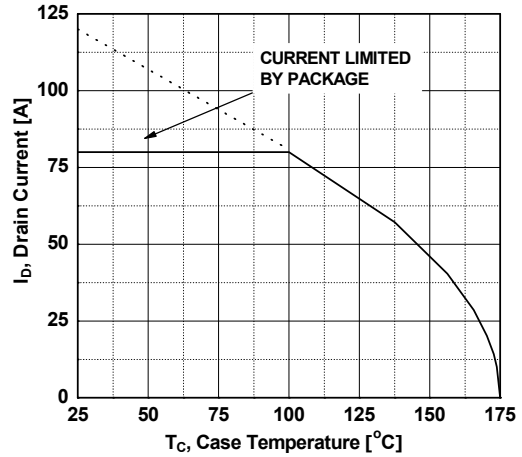
**Figure 8. On-Resistance Variation vs. Temperature**



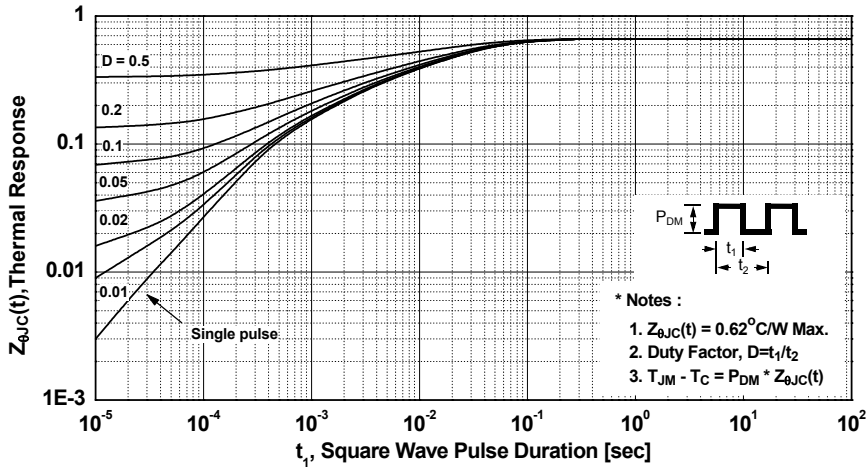
**Figure 9. Maximum Safe Operating Area**



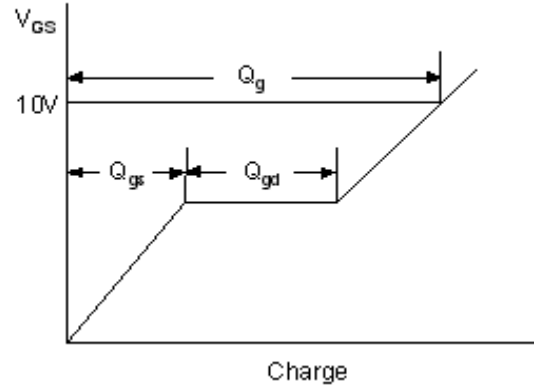
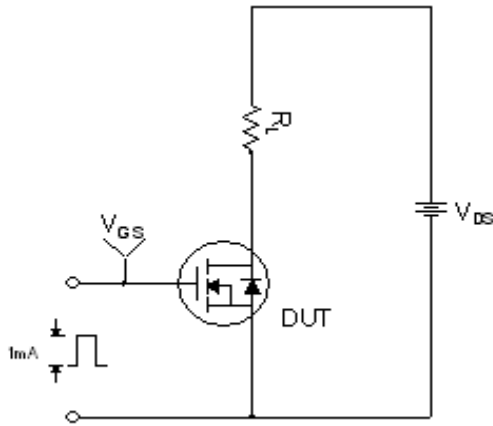
**Figure 10. Maximum Drain Current vs. Case Temperature**



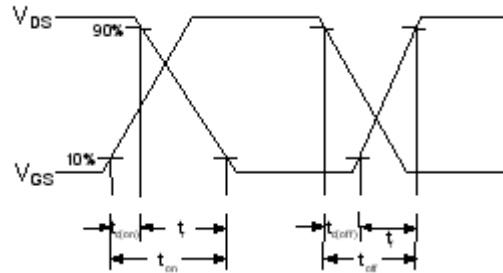
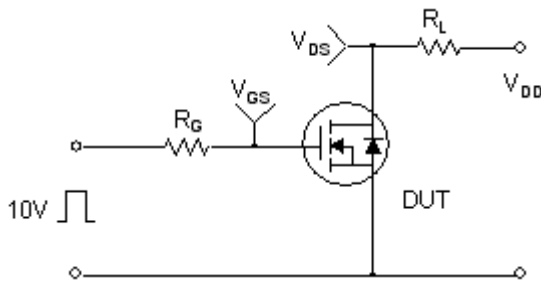
**Figure 11. Transient Thermal Response Curve**



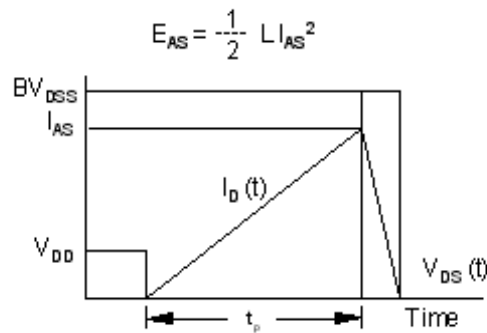
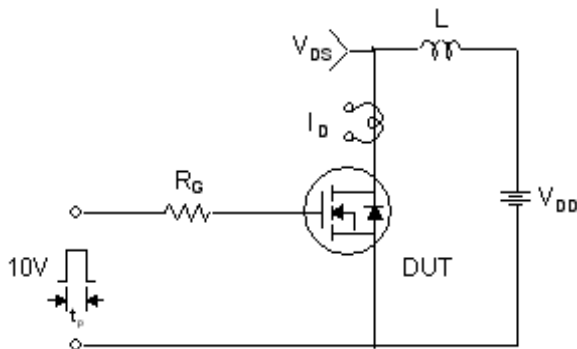
**Gate Charge Test Circuit & Waveform**



**Resistive Switching Test Circuit & Waveforms**



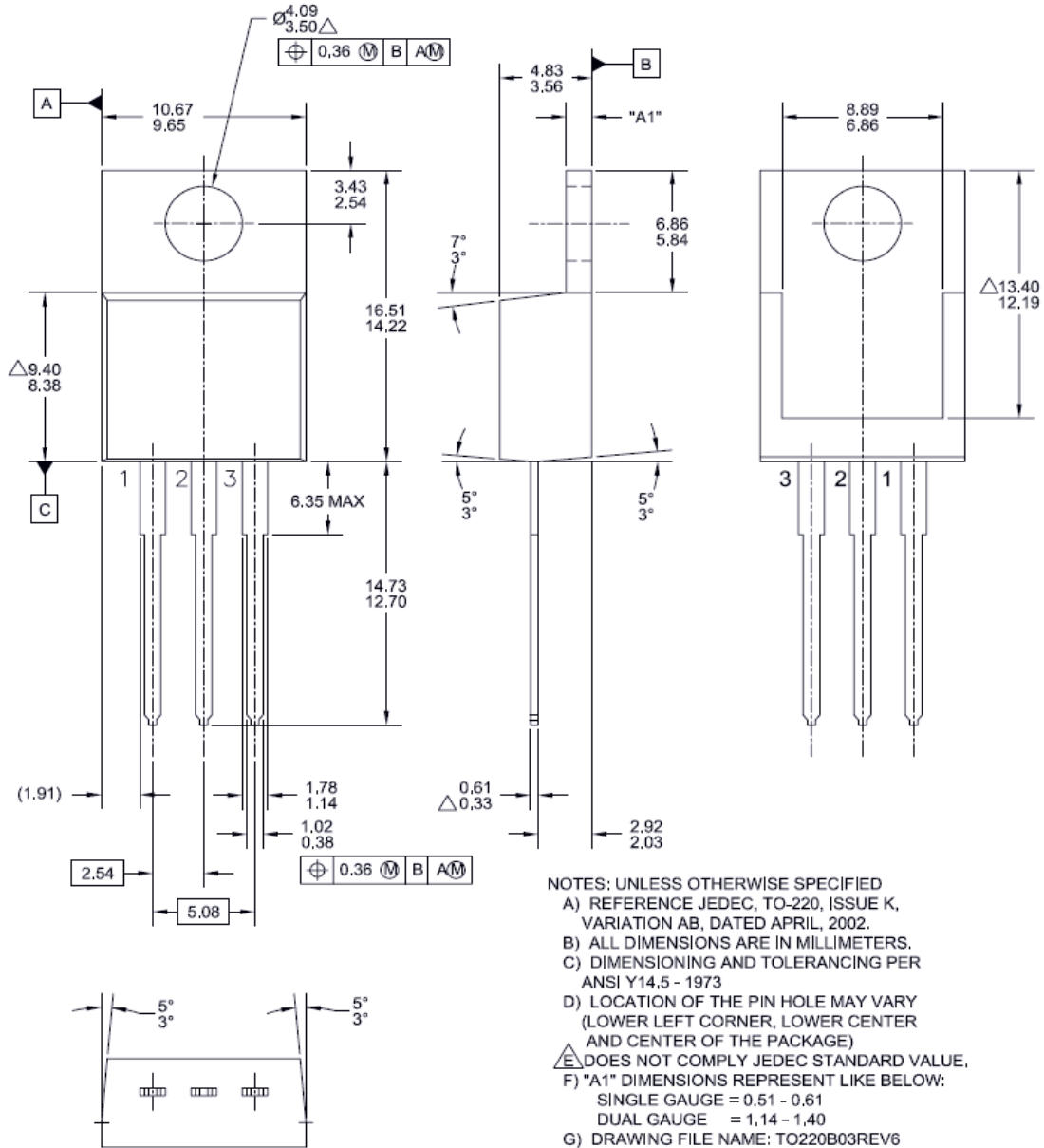
**Unclamped Inductive Switching Test Circuit & Waveforms**





**Mechanical Dimensions**

**TO-220B03**






Dimensions in Millimeters



**TRADEMARKS**

The following includes registered and unregistered trademarks and service marks, owned by Fairchild Semiconductor and/or its global subsidiaries, and is not intended to be an exhaustive list of all such trademarks.

- |  |   |   |   |
|--|---|---|---|
| 2Cool™   | FPS™  | PowerTrench®  | Sync-Lock™  |
| AccuPower™   | F-PFS™  | PowerXS™  | <b>SYSTEM GENERAL</b> ®*  |
| AX-CAP®*   | FRFET®  | Programmable Active Droop™  | TinyBoost™  |
| BitSiC™  | Global Power Resource <sup>SM</sup>             | QFET®   | TinyBuck™   |
| Build it Now™  | Green Bridge™                                   | QS™   | TinyCalc™   |
| CorePLUS™  | Green FPS™                                      | Quiet Series™   | TinyLogic®  |
| CorePOWER™   | Green FPS™ e-Series™                            | RapidConfigure™   | TINYOPTO™   |
| CROSSVOLT™   | Gmax™   |  Saving our world, 1mW/W/kW at a time™ | TinyPower™  |
| CTL™   | GTO™  | SignalWise™   | TinyPWM™  |
| Current Transfer Logic™  | IntelliMAX™                                     | SmartMax™   | TinyWire™   |
| DEUXPEED®  | ISOPLANAR®                                      | SMART START™  | TranSiC®  |
| Dual Cool™   | Marking Small Speakers Sound Louder and Better™ | Solutions for Your Success™   | TriFault Detect™  |
| EcoSPARK®  | MegaBuck™                                       | SPM®  | TRUECURRENT®*   |
| EfficientMax™  | MICROCOUPLER™                                   | STEALTH™  | µSerDes™  |
| ESBC™  | MicroFET™                                       | SuperFET®   |  SerDes™ |
|  Fairchild® | MicroPak™                                       | SuperSOT™_3   | UHC™  |
| Fairchild Semiconductor®   | MicroPak2™                                      | SuperSOT™_6   | Ultra FRFET™  |
| FACT Quiet Series™   | MillerDrive™                                    | SuperSOT™_8   | UniFET™   |
| FACT®  | MotionMax™                                      | SupreMOS®   | VCX™  |
| FAST®  | mWSaver™  | SyncFET™  | VisualMax™  |
| FastvCore™   | OptoHiT™  |   | VoltagePlus™  |
| FETBench™  | OPTOLOGIC®                                      |   | XS™   |
|  | OPTOPLANAR®                                     |   |   |

\*Trademarks of System General Corporation, used under license by Fairchild Semiconductor.

**DISCLAIMER**

FAIRCHILD SEMICONDUCTOR RESERVES THE RIGHT TO MAKE CHANGES WITHOUT FURTHER NOTICE TO ANY PRODUCTS HEREIN TO IMPROVE RELIABILITY, FUNCTION, OR DESIGN. FAIRCHILD DOES NOT ASSUME ANY LIABILITY ARISING OUT OF THE APPLICATION OR USE OF ANY PRODUCT OR CIRCUIT DESCRIBED HEREIN; NEITHER DOES IT CONVEY ANY LICENSE UNDER ITS PATENT RIGHTS, NOR THE RIGHTS OF OTHERS. THESE SPECIFICATIONS DO NOT EXPAND THE TERMS OF FAIRCHILD'S WORLDWIDE TERMS AND CONDITIONS, SPECIFICALLY THE WARRANTY THEREIN, WHICH COVERS THESE PRODUCTS.

**LIFE SUPPORT POLICY**

FAIRCHILD'S PRODUCTS ARE NOT AUTHORIZED FOR USE AS CRITICAL COMPONENTS IN LIFE SUPPORT DEVICES OR SYSTEMS WITHOUT THE EXPRESS WRITTEN APPROVAL OF FAIRCHILD SEMICONDUCTOR CORPORATION.

As used here in:

- Life support devices or systems are devices or systems which, (a) are intended for surgical implant into the body or (b) support or sustain life, and (c) whose failure to perform when properly used in accordance with instructions for use provided in the labeling, can be reasonably expected to result in a significant injury of the user.
- A critical component in any component of a life support, device, or system whose failure to perform can be reasonably expected to cause the failure of the life support device or system, or to affect its safety or effectiveness.

**ANTI-COUNTERFEITING POLICY**

Fairchild Semiconductor Corporation's Anti-Counterfeiting Policy. Fairchild's Anti-Counterfeiting Policy is also stated on our external website, www.fairchildsemi.com, under Sales Support.

Counterfeiting of semiconductor parts is a growing problem in the industry. All manufactures of semiconductor products are experiencing counterfeiting of their parts. Customers who inadvertently purchase counterfeit parts experience many problems such as loss of brand reputation, substandard performance, failed application, and increased cost of production and manufacturing delays. Fairchild is taking strong measures to protect ourselves and our customers from the proliferation of counterfeit parts. Fairchild strongly encourages customers to purchase Fairchild parts either directly from Fairchild or from Authorized Fairchild Distributors who are listed by country on our web page cited above. Products customers buy either from Fairchild directly or from Authorized Fairchild Distributors are genuine parts, have full traceability, meet Fairchild's quality standards for handling and storage and provide access to Fairchild's full range of up-to-date technical and product information. Fairchild and our Authorized Distributors will stand behind all warranties and will appropriately address and warranty issues that may arise. Fairchild will not provide any warranty coverage or other assistance for parts bought from Unauthorized Sources. Fairchild is committed to combat this global problem and encourage our customers to do their part in stopping this practice by buying direct or from authorized distributors.

**PRODUCT STATUS DEFINITIONS**

**Definition of Terms**

Datasheet Identification	Product Status	Definition
Advance Information	Formative / In Design	Datasheet contains the design specifications for product development. Specifications may change in any manner without notice.
Preliminary	First Production	Datasheet contains preliminary data; supplementary data will be published at a later date. Fairchild Semiconductor reserves the right to make changes at any time without notice to improve design.
No Identification Needed	Full Production	Datasheet contains final specifications. Fairchild Semiconductor reserves the right to make changes at any time without notice to improve the design.
Obsolete	Not In Production	Datasheet contains specifications on a product that is discontinued by Fairchild Semiconductor. The datasheet is for reference information only.

Rev. I64



LittleDiode supplies new, hard to find or obsolete electronic components and semiconductors all over the world.

With over two million different components listed you are sure to find the part you need.

Feel free to visit us today at our online store:

[LittleDiode.com](http://LittleDiode.com)

Looking forward to providing you with the best possible service.