

FDT461N

N-Channel Logic Level PowerTrench® MOSFET 100V, 0.4A, 2.5Ω

Features

- $r_{DS(ON)} = 1.45\Omega$ (Typ.), $V_{GS} = 4.5V$, $I_D = 0.4A$
- $Q_g(tot) = 2.36nC$ (Typ.), $V_{GS} = 10V$
- Low Miller Charge
- Low Q_{RR} Body Diode

Applications

- Servo Motor Load Control
- DC-DC converters

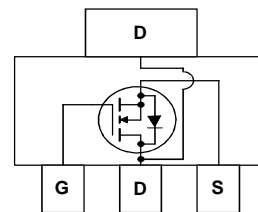
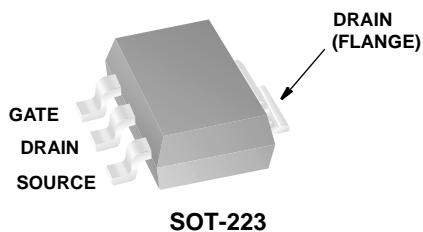

MOSFET Maximum Ratings $T_A = 25^\circ C$ unless otherwise noted

Symbol	Parameter	Ratings	Units
V_{DSS}	Drain to Source Voltage	100	V
V_{GS}	Gate to Source Voltage	± 20	V
I_D	Drain Current		
	Continuous ($T_A = 25^\circ C$, $V_{GS} = 10V$, $R_{\theta JA} = 110^\circ C/W$)	0.54	A
	Continuous ($T_A = 25^\circ C$, $V_{GS} = 4.5V$, $R_{\theta JA} = 110^\circ C/W$)	0.4	A
	Pulsed	Figure 4	A
E_{AS}	Single Pulse Avalanche Energy (Note 1)	6.3	mJ
P_D	Power dissipation	1.13	W
	Derate above $25^\circ C$	9	mW/ $^\circ C$
T_J, T_{STG}	Operating and Storage Temperature	-55 to 150	$^\circ C$

Thermal Characteristics

$R_{\theta JA}$	Thermal Resistance Junction to Ambient SOT-223, Pad area = 0.171 in ²	110	$^\circ C/W$
$R_{\theta JA}$	Thermal Resistance Junction to Ambient SOT-223, Pad area = 0.068 in ²	128	$^\circ C/W$
$R_{\theta JA}$	Thermal Resistance Junction to Ambient SOT-223, Pad area = 0.026 in ²	147	$^\circ C/W$

Package Marking and Ordering Information

Device Marking	Device	Package	Reel Size	Tape Width	Quantity
461	FDT461N	SOT-223	13"	12mm	2500 units

Electrical Characteristics $T_A = 25^\circ\text{C}$ unless otherwise noted

Symbol	Parameter	Test Conditions	Min	Typ	Max	Units
--------	-----------	-----------------	-----	-----	-----	-------

Off Characteristics

B_{VDSS}	Drain to Source Breakdown Voltage	$I_D = 250\mu\text{A}, V_{GS} = 0\text{V}$	100	-	-	V
I_{DSS}	Zero Gate Voltage Drain Current	$V_{DS} = 80\text{V}$	-	-	1	μA
		$V_{GS} = 0\text{V}$ $T_C = 125^\circ\text{C}$	-	-	250	
I_{GSS}	Gate to Source Leakage Current	$V_{GS} = \pm 20\text{V}$	-	-	± 100	nA

On Characteristics

$V_{GS(TH)}$	Gate to Source Threshold Voltage	$V_{GS} = V_{DS}, I_D = 250\mu\text{A}$	0.8	-	2	V
$r_{DS(ON)}$	Drain to Source On Resistance	$I_D = 0.54\text{A}, V_{GS} = 10\text{V}$	-	1.40	2.0	Ω
		$I_D = 0.4\text{A}, V_{GS} = 4.5\text{V}$	-	1.45	2.5	
		$I_D = 0.54\text{A}, V_{GS} = 10\text{V}, T_J = 150^\circ\text{C}$	-	2.80	4.0	

Dynamic Characteristics

C_{ISS}	Input Capacitance	$V_{DS} = 25\text{V}, V_{GS} = 0\text{V}, f = 1\text{MHz}$	-	74	-	pF	
C_{OSS}	Output Capacitance		-	11	-	pF	
C_{RSS}	Reverse Transfer Capacitance		-	2.5	-	pF	
$Q_{g(TOT)}$	Total Gate Charge at 10V	$V_{GS} = 0\text{V to } 10\text{V}$	$V_{DD} = 50\text{V}$ $I_D = 0.54\text{A}$ $I_g = 1.0\text{mA}$	2.36	4.0	nC	
$Q_{g(4.5)}$	Total Gate Charge at 4.5V	$V_{GS} = 0\text{V to } 4.5\text{V}$		-	1.27	2.0	nC
$Q_{g(TH)}$	Threshold Gate Charge	$V_{GS} = 0\text{V to } 1\text{V}$		0.1	0.15	nC	
Q_{gs}	Gate to Source Gate Charge			-	0.37	-	nC
Q_{gs2}	Gate Charge Threshold to Plateau			-	0.27	-	nC
Q_{gd}	Gate to Drain "Miller" Charge			-	0.25	-	nC

Switching Characteristics ($V_{GS} = 10\text{V}$)

t_{ON}	Turn-On Time	$V_{DD} = 50\text{V}, I_D = 0.54\text{A}$ $V_{GS} = 10\text{V}, R_{GS} = 120\Omega$	-	-	6.5	ns
$t_{d(ON)}$	Turn-On Delay Time		-	3	-	ns
t_r	Rise Time		-	1.3	-	ns
$t_{d(OFF)}$	Turn-Off Delay Time		-	63	-	ns
t_f	Fall Time		-	12	-	ns
t_{OFF}	Turn-Off Time		-	-	113	ns

Drain-Source Diode Characteristics

V_{SD}	Source to Drain Diode Voltage	$I_{SD} = 0.54\text{A}$	-	-	1.25	V
		$I_{SD} = 0.3\text{A}$	-	-	1.0	V
t_{rr}	Reverse Recovery Time	$I_{SD} = 0.54\text{A}, di_{SD}/dt = 100\text{A}/\mu\text{s}$	-	-	22	ns
Q_{RR}	Reverse Recovered Charge	$I_{SD} = 0.54\text{A}, di_{SD}/dt = 100\text{A}/\mu\text{s}$	-	-	18	nC

Notes:

1: Starting $T_J = 25^\circ\text{C}$, $L = 67\text{mH}$, $I_{AS} = 0.43\text{A}$.

Typical Characteristics $T_A = 25^\circ\text{C}$ unless otherwise noted

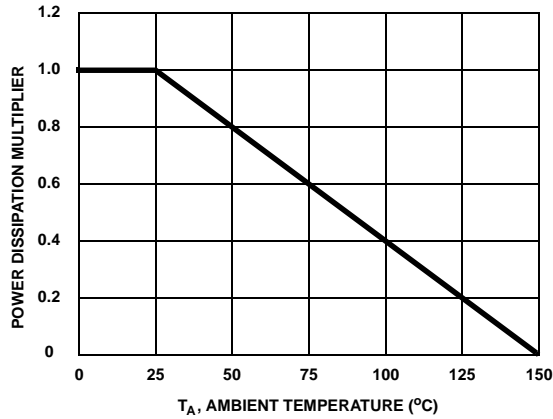

Figure 1. Normalized Power Dissipation vs Ambient Temperature

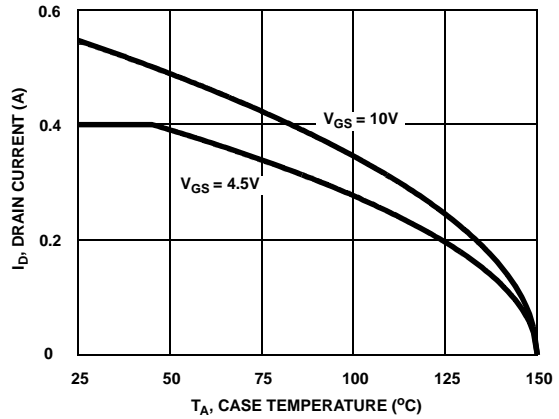

Figure 2. Maximum Continuous Drain Current vs Case Temperature

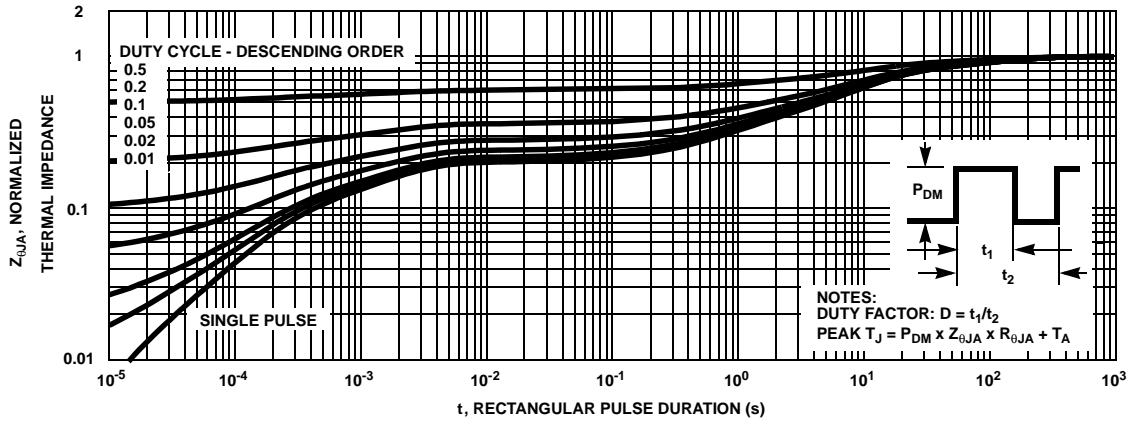

Figure 3. Normalized Maximum Transient Thermal Impedance

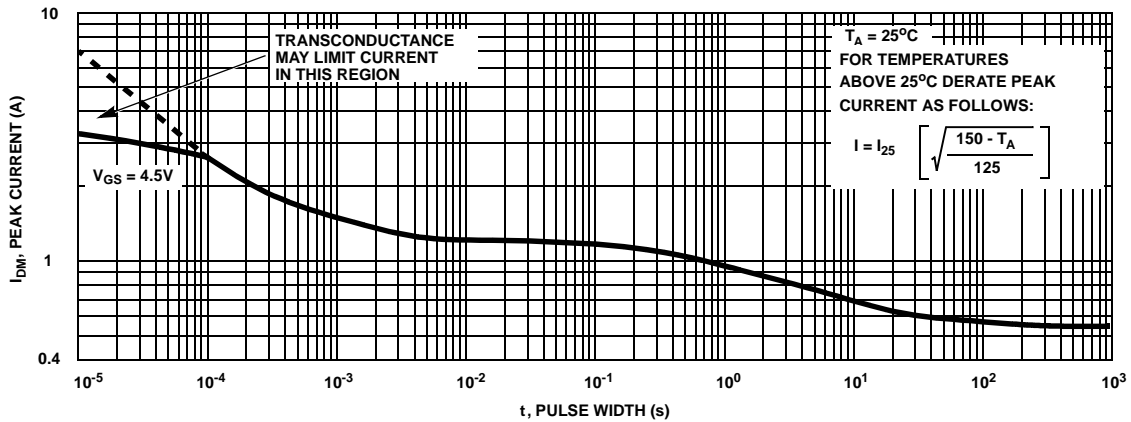

Figure 4. Peak Current Capability

Typical Characteristics $T_A = 25^\circ\text{C}$ unless otherwise noted

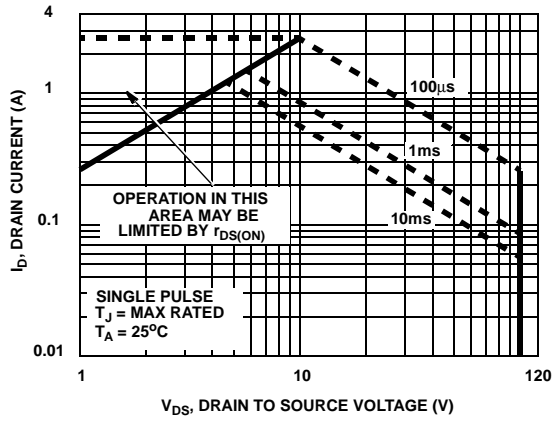

Figure 5. Forward Bias Safe Operating Area

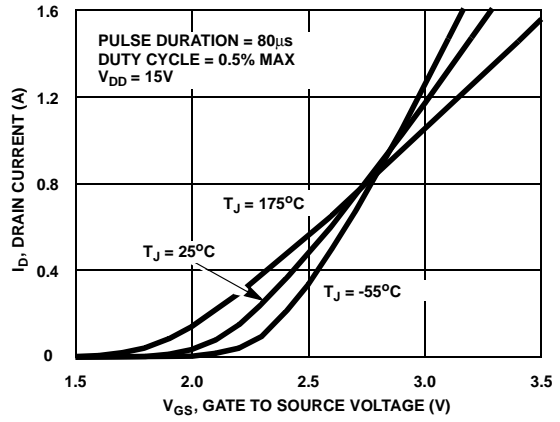

Figure 6. Transfer Characteristics

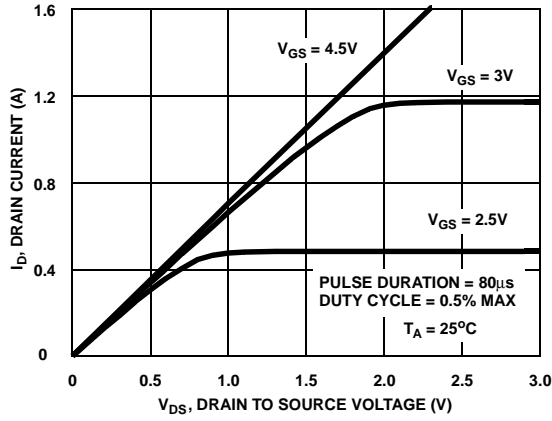

Figure 7. Saturation Characteristics

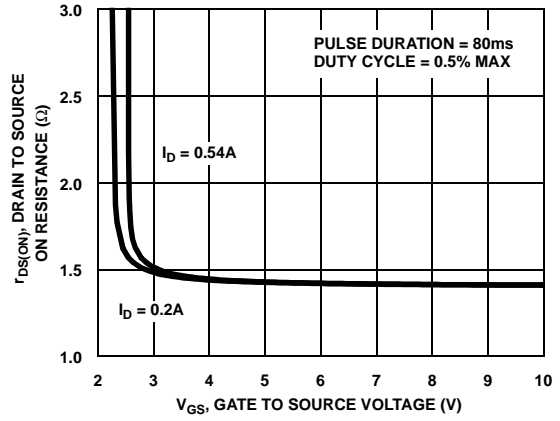

Figure 8. Drain to Source On Resistance vs Gate Voltage and Drain Current

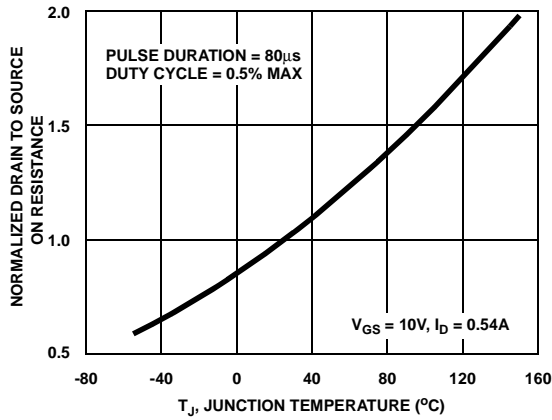

Figure 9. Normalized Drain to Source On Resistance vs Junction Temperature

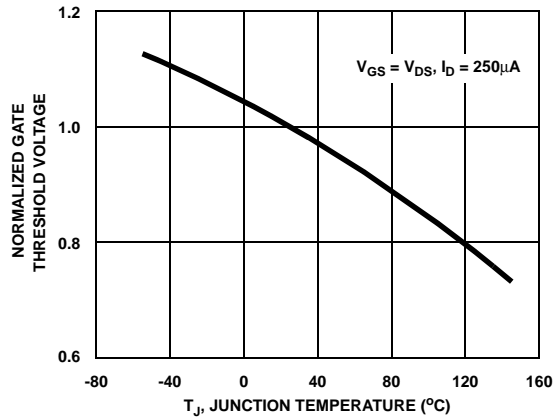

Figure 10. Normalized Gate Threshold Voltage vs Junction Temperature

Typical Characteristics $T_A = 25^\circ\text{C}$ unless otherwise noted

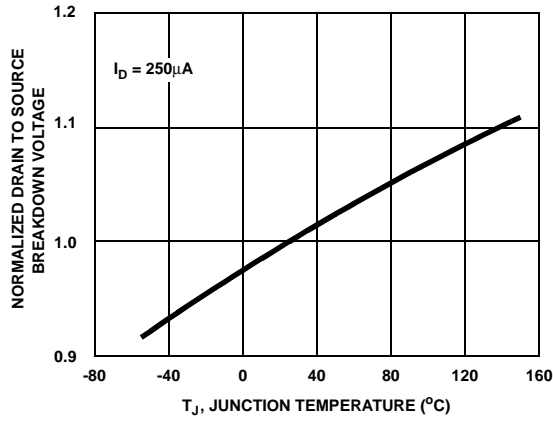

Figure 11. Normalized Drain to Source Breakdown Voltage vs Junction Temperature

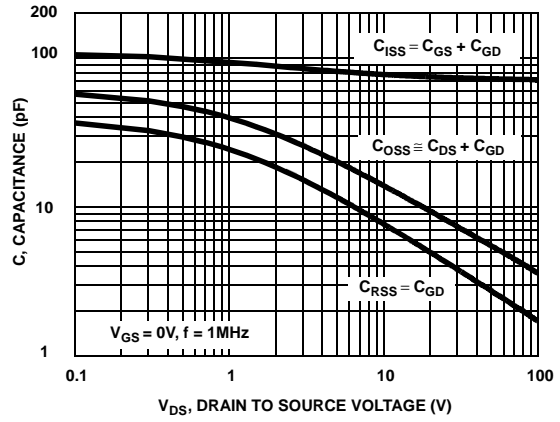

Figure 12. Capacitance vs Drain to Source Voltage

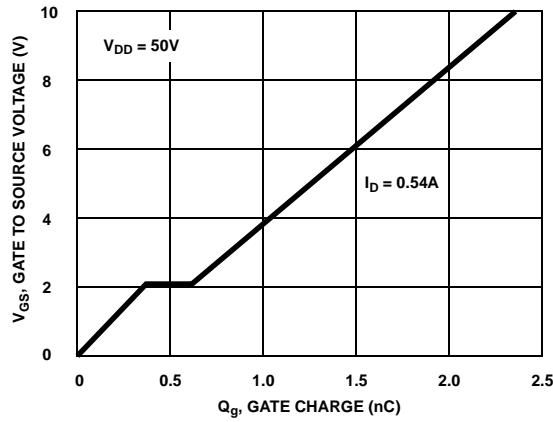

Figure 13. Gate Charge Waveforms for Constant Gate Current

Test Circuits and Waveforms

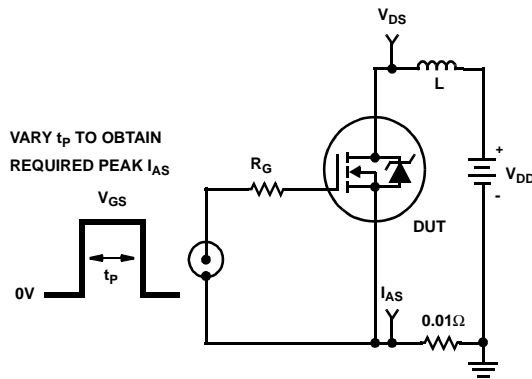

Figure 14. Unclamped Energy Test Circuit

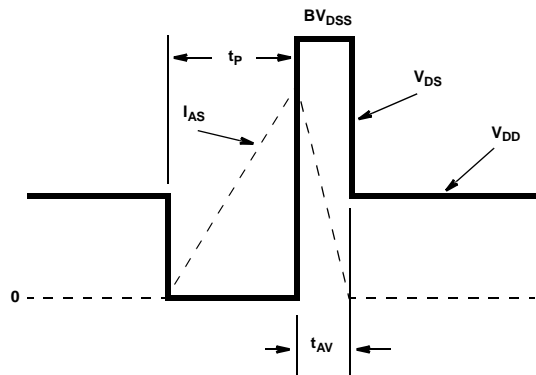

Figure 15. Unclamped Energy Waveforms

Test Circuits and Waveforms (Continued)

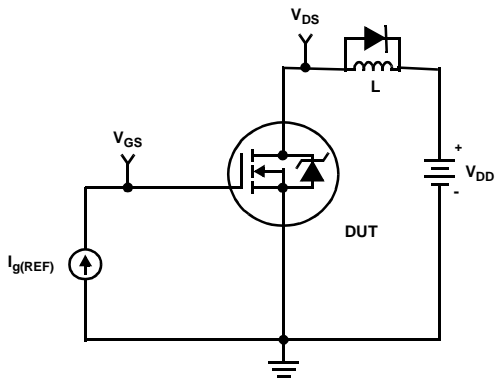

Figure 16. Gate Charge Test Circuit

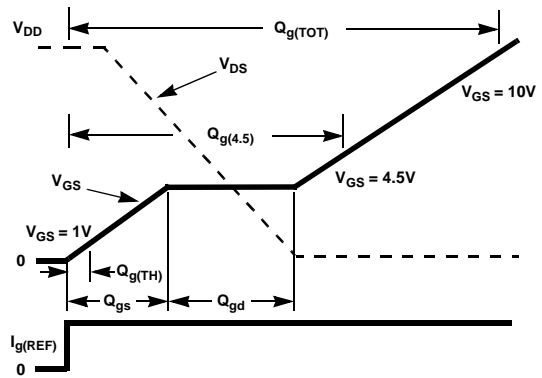

Figure 17. Gate Charge Waveforms

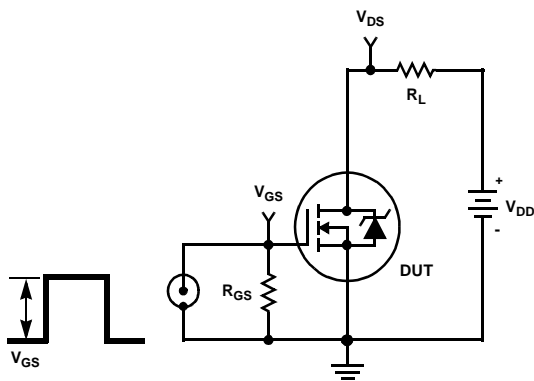

Figure 18. Switching Time Test Circuit

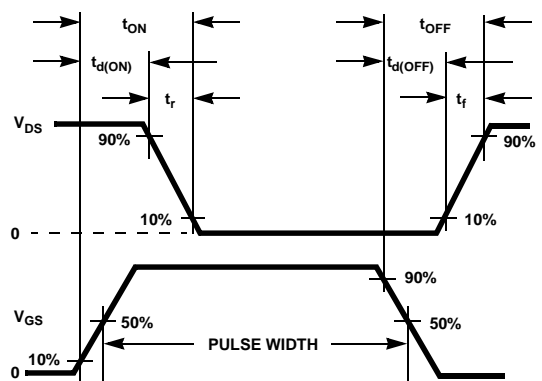

Figure 19. Switching Time Waveforms

PSPICE Electrical Model

.SUBCKT FDT461N 2 1 3 ; rev January 2004
 Ca 12 8 1.5e-10
 Cb 15 14 1.1e-10
 Cin 6 8 7.0e-11

Dbody 7 5 DbodyMOD
 Dbreak 5 11 DbreakMOD
 Dplcap 10 5 DplcapMOD

Ebreak 11 7 17 18 109.7
 Eds 14 8 5 8 1
 Egs 13 8 6 8 1
 Esg 6 10 6 8 1
 Evthres 6 21 19 8 1
 Evtemp 20 6 18 22 1

It 8 17 1

Lgate 1 9 5.29e-9
 Ldrain 2 5 1.0e-9
 Lsource 3 7 5.71e-9

RLgate 1 9 52.9
 RLdrain 2 5 10
 RLsource 3 7 57.1

Mmed 16 6 8 8 MmedMOD
 Mstro 16 6 8 8 MstroMOD
 Mweak 16 21 8 8 MweakMOD

Rbreak 17 18 RbreakMOD 1
 Rdrain 50 16 RdrainMOD 0.9
 Rgate 9 20 3.94
 RSLC1 5 51 RSLCMOD 1e-6
 RSLC2 5 50 1e3
 Rsource 8 7 RsourceMOD 0.5
 Rvthres 22 8 RvthresMOD 1
 Rvtemp 18 19 RvtempMOD 1
 S1a 6 12 13 8 S1AMOD
 S1b 13 12 13 8 S1BMOD
 S2a 6 15 14 13 S2AMOD
 S2b 13 15 14 13 S2BMOD

Vbat 22 19 DC 1

ESLC 51 50 VALUE={{(V(5,51)/ABS(V(5,51)))*(PWR(V(5,51))/(1e-6*15),2.5))}}

.MODEL DbodyMOD D (IS=6.4E-11 RS=8.0e-3 IKF=0.9 TRS1=2.5e-3 TRS2=9.5e-6
 + CJO=2.2e-11 M=0.52 TT=2.9e-8 XTI=0.1)

.MODEL DbreakMOD D (RS=0.6 TRS1=1.4e-3 TRS2=-5.0e-5)

.MODEL DplcapMOD D (CJO=3.9e-11 IS=1e-30 N=10 M=0.67)

.MODEL MmedMOD NMOS (VTO=1.75 KP=1.2 IS=1e-30 N=10 TOX=1 L=1u W=1u RG=3.94 T_ABS=25)

.MODEL MstroMOD NMOS (VTO=2.03 KP=12 IS=1e-30 N=10 TOX=1 L=1u W=1u T_ABS=25)

.MODEL MweakMOD NMOS (VTO=1.46 KP=0.02 IS=1e-30 N=10 TOX=1 L=1u W=1u RG=39.4 RS=0.1 T_ABS=25)

.MODEL RbreakMOD RES (TC1=1.0e-3 TC2=-8.8e-7)

.MODEL RdrainMOD RES (TC1=7.0e-3 TC2=2.0e-5)

.MODEL RSLCMOD RES (TC1=1.0e-3 TC2=9.0e-6)

.MODEL RsourceMOD RES (TC1=4.8e-3 TC2=1.0e-6)

.MODEL RvthresMOD RES (TC1=-9.0e-4 TC2=-7.0e-6)

.MODEL RvtempMOD RES (TC1=-2.1e-3 TC2=1.8e-6)

.MODEL S1AMOD VSWITCH (RON=1e-5 ROFF=0.1 VON=-5.0 VOFF=-2.0)

.MODEL S1BMOD VSWITCH (RON=1e-5 ROFF=0.1 VON=-2.0 VOFF=-5.0)

.MODEL S2AMOD VSWITCH (RON=1e-5 ROFF=0.1 VON=-0.4 VOFF=0.3)

.MODEL S2BMOD VSWITCH (RON=1e-5 ROFF=0.1 VON=0.3 VOFF=-0.4)

.ENDS

Note: For further discussion of the PSPICE model, consult **A New PSPICE Sub-Circuit for the Power MOSFET Featuring Global Temperature Options**; IEEE Power Electronics Specialist Conference Records, 1991, written by William J. Hepp and C. Frank Wheatley.

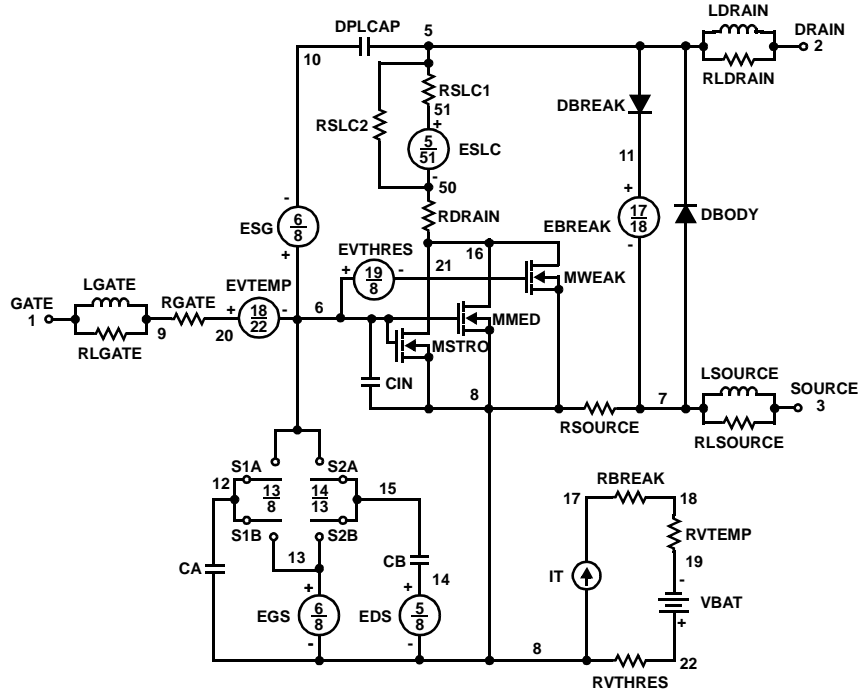

SABER Electrical Model

rev January 2004

template FDT461N n2,n1,n3 = m_temp

number m_temp=25

electrical n2,n1,n3

{

var i iscl

dp..model dbodymod = (isl=6.4e-11,rs=8.0e-3,ikf=0.9,trs1=2.5e-3,trs2=9.5e-6,cjo=2.2e-11,m=0.52,tt=2.9e-8,xti=0.1)

dp..model dbreakmod = (rs=0.6,trs1=1.4e-3,trs2=-5e-5)

dp..model dplcapmod = (cjo=3.9e-11,isl=10e-30,nl=10,m=0.67)

m..model mmedmod = (type=_n,vto=1.75,kp=1.2,is=1e-30,tox=1)

m..model mstrongmod = (type=_n,vto=2.03,kp=12,is=1e-30,tox=1)

m..model mweakmod = (type=_n,vto=1.46,kp=0.02,is=1e-30,tox=1,rs=0.1)

sw_vcsp..model s1amod = (ron=1e-5,roff=0.1,von=-5.0,voff=-2.0)

sw_vcsp..model s1bmod = (ron=1e-5,roff=0.1,von=-2.0,voff=-5.0)

sw_vcsp..model s2amod = (ron=1e-5,roff=0.1,von=-0.4,voff=0.3)

sw_vcsp..model s2bmod = (ron=1e-5,roff=0.1,von=0.3,voff=-0.4)

c.ca n12 n8 = 1.5e-10

c.cb n15 n14 = 1.1e-10

c.cin n6 n8 = 7.0e-11

dp.dbody n7 n5 = model=dbodymod

dp.dbreak n5 n11 = model=dbreakmod

dp.dplcap n10 n5 = model=dplcapmod

spe.ebreak n11 n7 n17 n18 = 109.7

spe.eds n14 n8 n5 n8 = 1

spe.egs n13 n8 n6 n8 = 1

spe.esg n6 n10 n6 n8 = 1

spe.evthres n6 n21 n19 n8 = 1

spe.evtemp n20 n6 n18 n22 = 1

i.it n8 n17 = 1

l.lgate n1 n9 = 5.29e-9

l.ldrain n2 n5 = 1.0e-9

l.lsource n3 n7 = 5.71e-9

res.rlgate n1 n9 = 52.9

res.rldrain n2 n5 = 10

res.rlsource n3 n7 = 57.1

m.mmed n16 n6 n8 n8 = model=mmedmod, temp=m_temp, l=1u, w=1u

m.mstrong n16 n6 n8 n8 = model=mstrongmod, temp=m_temp, l=1u, w=1u

m.mweak n16 n21 n8 n8 = model=mweakmod, temp=m_temp, l=1u, w=1u

res.rbreak n17 n18 = 1, tc1=1.0e-3,tc2=-8.8e-7

res.rdrain n50 n16 = 0.9, tc1=7.0e-3,tc2=2.0e-5

res.rgate n9 n20 = 3.94

res.rslc1 n5 n51 = 1e-6, tc1=1.0e-3,tc2=9.0e-6

res.rslc2 n5 n50 = 1e3

res.rsource n8 n7 = 0.5, tc1=4.8e-3,tc2=1e-6

res.rvthres n22 n8 = 1, tc1=-9.0e-4,tc2=-7.0e-6

res.rvtemp n18 n19 = 1, tc1=-2.1e-3,tc2=1.8e-6

sw_vcsp.s1a n6 n12 n13 n8 = model=s1amod

sw_vcsp.s1b n13 n12 n13 n8 = model=s1bmod

sw_vcsp.s2a n6 n15 n14 n13 = model=s2amod

sw_vcsp.s2b n13 n15 n14 n13 = model=s2bmod

v.vbat n22 n19 = dc=1

equations {

i (n51->n50) +=iscl

iscl: v(n51,n50) = ((v(n5,n51)/(1e-9+abs(v(n5,n51))))*((abs(v(n5,n51))*1e6/15)** 2.5))

}

}

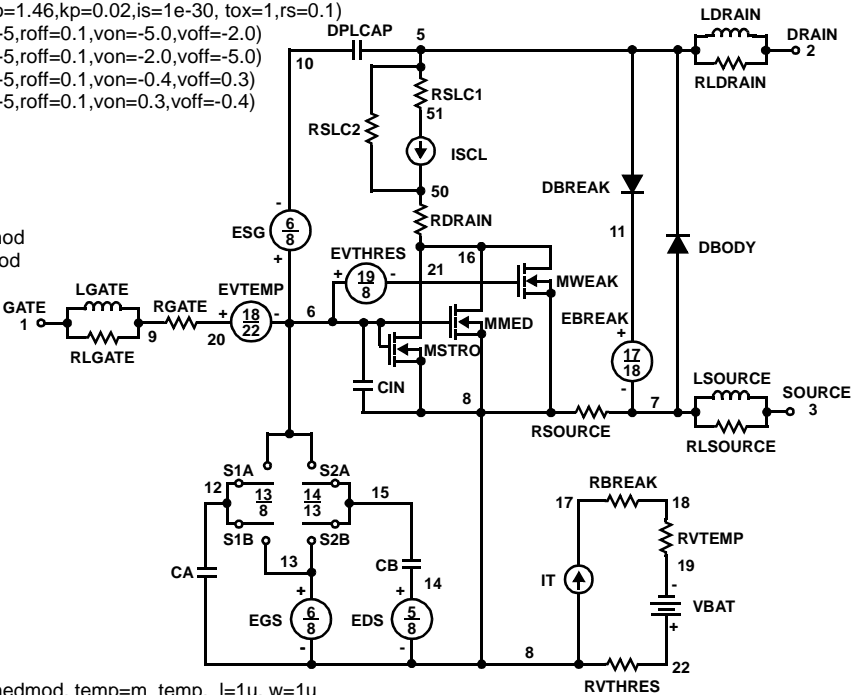

PSPICE Thermal Model

REV January 2004
 FDT461N_JA Junction Ambient
 Copper Area= 1sq.in

CTHERM1 Junction c2 3.0e-5
 CTHERM2 c2 c3 3.2e-5
 CTHERM3 c3 c4 2.0e-4
 CTHERM4 c4 c5 9.6e-2
 CTHERM5 c5 c6 8.9e-1
 CTHERM6 c6 c7 9.1e-1
 CTHERM7 c7 c8 9.3e-1
 CTHERM8 c8 Ambient 7

RTHERM1 Junction c2 0.5
 RTHERM2 c2 c3 6
 RTHERM3 c3 c4 9
 RTHERM4 c4 c5 10
 RTHERM5 c5 c6 11
 RTHERM6 c6 c7 12
 RTHERM7 c7 c8 13
 RTHERM8 c8 Ambient 16

SABER Thermal Model

SABER thermal model FDT461N
 Copper Area= 1sq.in
 template thermal_model th tl
 thermal_c th, tl

```
{
  ctherm.ctherm1 th c2 = 3.0e-5
  ctherm.ctherm2 c2 c3 = 3.2e-5
  ctherm.ctherm3 c3 c4 = 2.0e-4
  ctherm.ctherm4 c4 c5 = 9.6e-2
  ctherm.ctherm5 c5 c6 = 8.9e-1
  ctherm.ctherm6 c6 c7 = 9.1e-1
  ctherm.ctherm7 c7 c8 = 9.3e-1
  ctherm.ctherm8 c8 tl = 7
}
```

```
rtherm.rtherm1 th c2 = 0.5
rtherm.rtherm2 c2 c3 = 6
rtherm.rtherm3 c3 c4 = 9
rtherm.rtherm4 c4 c5 = 10
rtherm.rtherm5 c5 c6 = 11
rtherm.rtherm6 c6 c7 = 12
rtherm.rtherm7 c7 c8 = 13
rtherm.rtherm8 c8 tl = 16
}
```

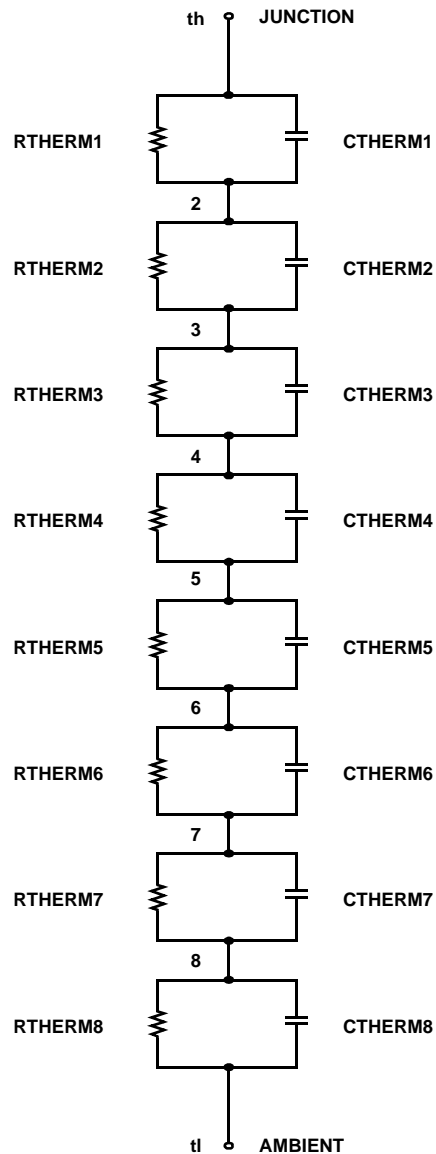

TRADEMARKS

The following are registered and unregistered trademarks Fairchild Semiconductor owns or is authorized to use and is not intended to be an exhaustive list of all such trademarks.

ACEx™	FACT Quiet Series™	ImpliedDisconnect™	PACMAN™	SPM™
ActiveArray™	FAST®	ISOPLANAR™	POP™	Stealth™
Bottomless™	FASTr™	LittleFET™	Power247™	SuperFET™
CoolFET™	FPST™	MICROCOUPLER™	PowerSaver™	SuperSOT™-3
CROSSVOLT™	FRFET™	MicroFET™	PowerTrench®	SuperSOT™-6
DOMET™	GlobalOptoisolator™	MicroPak™	QFET®	SuperSOT™-8
EcoSPARK™	GTO™	MICROWIRE™	QS™	SyncFET™
E ² CMOS™	HiSeC™	MSX™	QT Optoelectronics™	TinyLogic®
EnSigna™	µC™	MSXPro™	Quiet Series™	TINYOPTO™
FACT™	i-Lo™	OCX™	RapidConfigure™	TruTranslation™
Across the board. Around the world.™	OCXPro™	OCXPro™	RapidConnect™	UHC™
The Power Franchise®	OPTOLOGIC®	OPTOLOGIC®	SILENT SWITCHER®	UltraFET®
Programmable Active Droop™	OPTOPLANAR™	OPTOPLANAR™	SMART START™	VCX™

DISCLAIMER

FAIRCHILD SEMICONDUCTOR RESERVES THE RIGHT TO MAKE CHANGES WITHOUT FURTHER NOTICE TO ANY PRODUCTS HEREIN TO IMPROVE RELIABILITY, FUNCTION OR DESIGN. FAIRCHILD DOES NOT ASSUME ANY LIABILITY ARISING OUT OF THE APPLICATION OR USE OF ANY PRODUCT OR CIRCUIT DESCRIBED HEREIN; NEITHER DOES IT CONVEY ANY LICENSE UNDER ITS PATENT RIGHTS, NOR THE RIGHTS OF OTHERS.

LIFE SUPPORT POLICY

FAIRCHILD'S PRODUCTS ARE NOT AUTHORIZED FOR USE AS CRITICAL COMPONENTS IN LIFE SUPPORT DEVICES OR SYSTEMS WITHOUT THE EXPRESS WRITTEN APPROVAL OF FAIRCHILD SEMICONDUCTOR CORPORATION.

As used herein:

1. Life support devices or systems are devices or systems which, (a) are intended for surgical implant into the body, or (b) support or sustain life, or (c) whose failure to perform when properly used in accordance with instructions for use provided in the labeling, can be reasonably expected to result in significant injury to the user.
2. A critical component is any component of a life support device or system whose failure to perform can be reasonably expected to cause the failure of the life support device or system, or to affect its safety or effectiveness.

PRODUCT STATUS DEFINITIONS

Definition of Terms

Datasheet Identification	Product Status	Definition
Advance Information	Formative or In Design	This datasheet contains the design specifications for product development. Specifications may change in any manner without notice.
Preliminary	First Production	This datasheet contains preliminary data, and supplementary data will be published at a later date. Fairchild Semiconductor reserves the right to make changes at any time without notice in order to improve design.
No Identification Needed	Full Production	This datasheet contains final specifications. Fairchild Semiconductor reserves the right to make changes at any time without notice in order to improve design.
Obsolete	Not In Production	This datasheet contains specifications on a product that has been discontinued by Fairchild semiconductor. The datasheet is printed for reference information only.



LittleDiode supplies new, hard to find or obsolete electronic components and semiconductors all over the world.

With over two million different components listed you are sure to find the part you need.

Feel free to visit us today at our online store:

LittleDiode.com

Looking forward to providing you with the best possible service.