

## FDC6326L Integrated Load Switch

### General Description

This device is particularly suited for compact power management in portable electronic equipment where 3V to 20V input and 1.8A output current capability are needed. This load switch integrates a small N-Channel power MOSFET (Q1) which drives a large P-Channel power MOSFET (Q2) in one tiny SuperSOT™-6 package.

### Features

- $V_{DROPP}=0.20V$  @  $V_{IN}=12V, I_L=1.5A, R_{DS(ON)} = 0.125 \Omega$   
 $V_{DROPP}=0.20V$  @  $V_{IN}=5V, I_L=1A, R_{DS(ON)} = 0.20 \Omega$ .
- SuperSOT™-6 package design using copper lead frame for superior thermal and electrical capabilities.

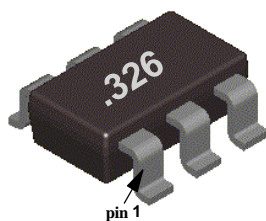

SuperSOT™-6

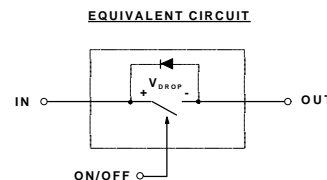
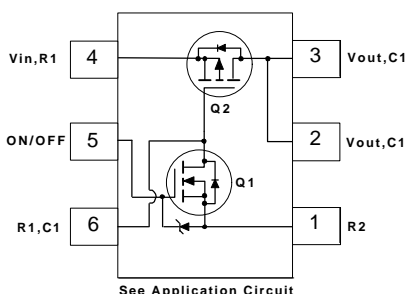

### Absolute Maximum Ratings $T_A = 25^\circ C$ unless otherwise noted

| Symbol         | Parameter  | FDC6326L   | Units      |
|----------------|--|------------|------------|
| $V_{IN}$       | Input Voltage Range  | 3 - 20     | V          |
| $V_{ON/OFF}$   | On/Off Voltage Range   | 2.5 - 8    | V          |
| $I_L$          | Load Current - Continuous (Note 1)   | 1.8        | A          |
|                | - Pulsed (Note 1 & 3)  | 5          |            |
| $P_D$          | Maximum Power Dissipation (Note 2)   | 0.7        | W          |
| $T_J, T_{STG}$ | Operating and Storage Temperature Range                                      | -55 to 150 | $^\circ C$ |
| ESD            | Electrostatic Discharge Rating MIL-STD-883D Human Body Model (100pf/1500Ohm) | 6          | kV         |

### THERMAL CHARACTERISTICS

|                 |  |     |              |
|-----------------|--|-----|--------------|
| $R_{\theta JA}$ | Thermal Resistance, Junction-to-Ambient (Note 2) | 180 | $^\circ C/W$ |
| $R_{\theta JC}$ | Thermal Resistance, Junction-to-Case (Note 2)    | 60  | $^\circ C/W$ |

## Electrical Characteristics ( $T_A = 25^\circ\text{C}$ unless otherwise noted)

| Symbol                             | Parameter                    | Conditions   | Min | Typ   | Max   | Units         |
|------------------------------------|------------------------------|--|-----|-------|-------|---------------|
| <b>OFF CHARACTERISTICS</b>         |                              |  |     |       |       |               |
| $I_{FL}$                           | Forward Leakage Current      | $V_{IN} = 20\text{ V}, V_{ON/OFF} = 0\text{ V}$                              |     |       | 1     | $\mu\text{A}$ |
| <b>ON CHARACTERISTICS (Note 3)</b> |                              |  |     |       |       |               |
| $V_{DROP}$                         | Conduction Voltage Drop      | $V_{IN} = 12\text{ V}, V_{ON/OFF} = 3.3\text{ V}, I_L = 1.5\text{ A}$        |     | 0.15  | 0.2   | V             |
|                                    |                              | $V_{IN} = 5\text{ V}, V_{ON/OFF} = 3.3\text{ V}, I_L = 1\text{ A}$           |     | 0.14  | 0.2   |               |
| $R_{DS(ON)}$                       | $Q_2$ - Static On-Resistance | $V_{GS} = -12\text{ V}, I_D = -1.9\text{ A}$                                 |     | 0.095 | 0.125 | $\Omega$      |
|                                    |                              | $V_{GS} = -5\text{ V}, I_D = -1.5\text{ A}$                                  |     | 0.14  | 0.2   |               |
| $I_L$                              | Load Current                 | $V_{DROP} = 0.125\text{ V}, V_{IN} = 12\text{ V}, V_{ON/OFF} = 3.3\text{ V}$ | 1   |       |       | A             |
|                                    |                              | $V_{DROP} = 0.20\text{ V}, V_{IN} = 5\text{ V}, V_{ON/OFF} = 3.3\text{ V}$   | 1   |       |       |               |

### Notes:

- $V_{IN} = 20\text{ V}, V_{ON/OFF} = 8\text{ V}, T_A = 25^\circ\text{C}$
- $R_{\theta JA}$  is the sum of the junction-to-case and case-to-ambient thermal resistance where the case thermal reference is defined as the solder mounting surface of the drain pins.  $R_{\theta JC}$  is guaranteed by design while  $R_{\theta CA}$  is determined by the user's board design.
- Pulse Test: Pulse Width  $\leq 300\mu\text{s}$ , Duty Cycle  $\leq 2.0\%$ .

## FDC6326L Load Switch Application

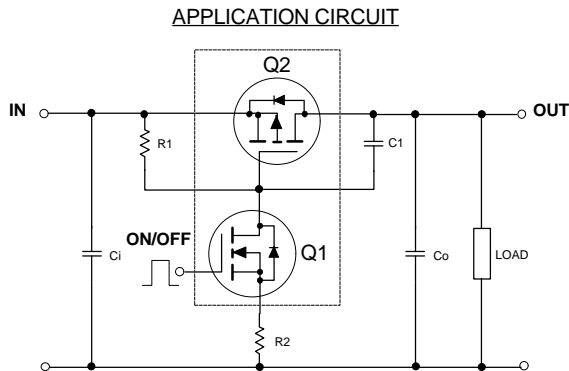

### External Component Recommendation

First select  $R_2$ , 100 - 1k $\Omega$ , for Slew Rate control.

$C_1 \leq 1000\text{pF}$  can be added in addition to  $R_2$  for further In-rush current control.

Then select  $R_1$  such that  $R_1/R_2$  ratio maintains between 10 - 100.  $R_1$  is required to turn  $Q_2$  off.

For SPICE simulation, users can download a "FDC6326L.MOD" Spice model from Fairchild Web Site at [www.fairchildsemi.com](http://www.fairchildsemi.com)

**Typical Electrical Characteristics** ( $T_A = 25\text{ }^\circ\text{C}$  unless otherwise noted )

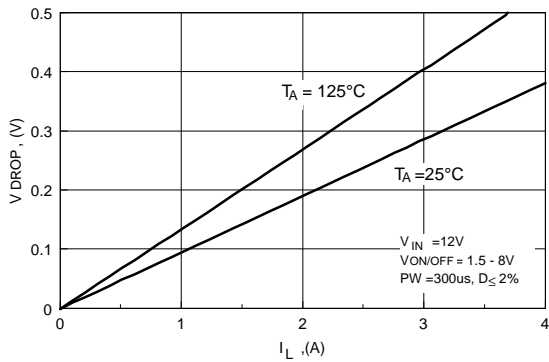

**Figure 1. Conduction Voltage Drop Variation with Load Current.**

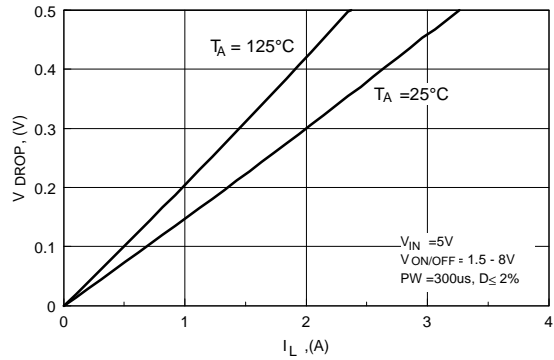

**Figure 2. Conduction Voltage Drop Variation with Load Current.**

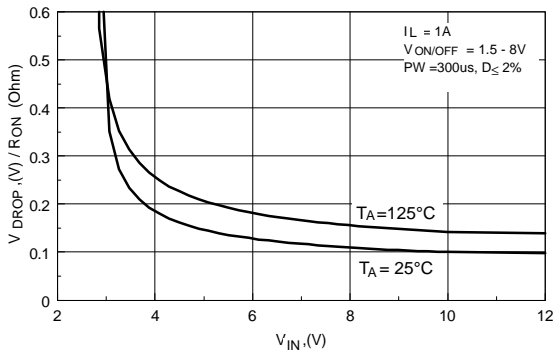

**Figure 3. On-Resistance Variation with Input Voltage.**

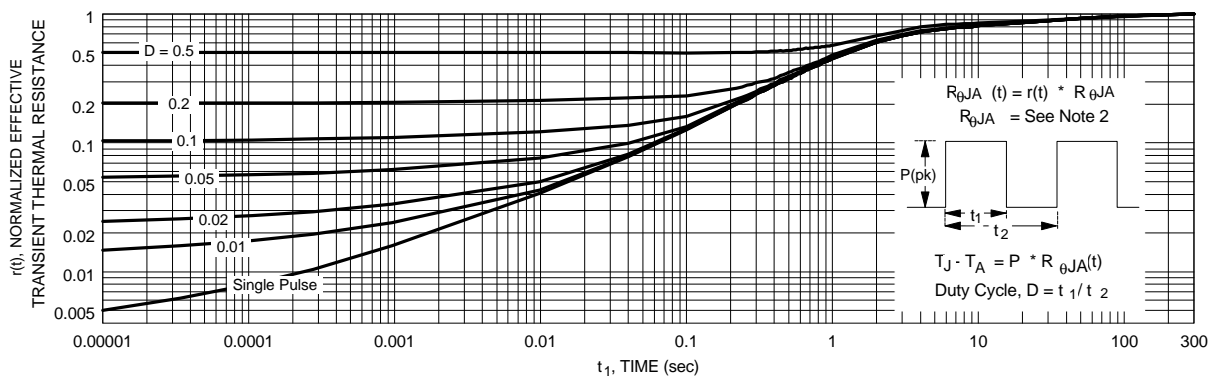

**Figure 4. Transient Thermal Response Curve.**

Thermal characterization performed on the conditions described in Note 2.

## TRADEMARKS

The following are registered and unregistered trademarks Fairchild Semiconductor owns or is authorized to use and is not intended to be an exhaustive list of all such trademarks.

|                      |               |            |
|----------------------|---------------|------------|
| ACEx™                | ISOPLANAR™    | TinyLogic™ |
| CoolFET™             | MICROWIRE™    | UHC™       |
| CROSSVOLT™           | POP™          | VCX™       |
| E <sup>2</sup> CMOS™ | PowerTrench™  |            |
| FACT™                | QFET™         |            |
| FACT Quiet Series™   | QS™           |            |
| FAST®                | Quiet Series™ |            |
| FASTr™               | SuperSOT™-3   |            |
| GTO™                 | SuperSOT™-6   |            |
| HiSeC™               | SuperSOT™-8   |            |

## DISCLAIMER

FAIRCHILD SEMICONDUCTOR RESERVES THE RIGHT TO MAKE CHANGES WITHOUT FURTHER NOTICE TO ANY PRODUCTS HEREIN TO IMPROVE RELIABILITY, FUNCTION OR DESIGN. FAIRCHILD DOES NOT ASSUME ANY LIABILITY ARISING OUT OF THE APPLICATION OR USE OF ANY PRODUCT OR CIRCUIT DESCRIBED HEREIN; NEITHER DOES IT CONVEY ANY LICENSE UNDER ITS PATENT RIGHTS, NOR THE RIGHTS OF OTHERS.

## LIFE SUPPORT POLICY

FAIRCHILD'S PRODUCTS ARE NOT AUTHORIZED FOR USE AS CRITICAL COMPONENTS IN LIFE SUPPORT DEVICES OR SYSTEMS WITHOUT THE EXPRESS WRITTEN APPROVAL OF FAIRCHILD SEMICONDUCTOR CORPORATION. As used herein:

1. Life support devices or systems are devices or systems which, (a) are intended for surgical implant into the body, or (b) support or sustain life, or (c) whose failure to perform when properly used in accordance with instructions for use provided in the labeling, can be reasonably expected to result in significant injury to the user.
2. A critical component is any component of a life support device or system whose failure to perform can be reasonably expected to cause the failure of the life support device or system, or to affect its safety or effectiveness.

## PRODUCT STATUS DEFINITIONS

### Definition of Terms

| Datasheet Identification | Product Status         | Definition  |
|--------------------------|------------------------|---|
| Advance Information      | Formative or In Design | This datasheet contains the design specifications for product development. Specifications may change in any manner without notice.  |
| Preliminary              | First Production       | This datasheet contains preliminary data, and supplementary data will be published at a later date. Fairchild Semiconductor reserves the right to make changes at any time without notice in order to improve design. |
| No Identification Needed | Full Production        | This datasheet contains final specifications. Fairchild Semiconductor reserves the right to make changes at any time without notice in order to improve design.   |
| Obsolete                 | Not In Production      | This datasheet contains specifications on a product that has been discontinued by Fairchild semiconductor. The datasheet is printed for reference information only.   |



LittleDiode supplies new, hard to find or obsolete electronic components and semiconductors all over the world.

With over two million different components listed you are sure to find the part you need.

Feel free to visit us today at our online store:

[LittleDiode.com](http://LittleDiode.com)

Looking forward to providing you with the best possible service.