

**2.3A, 80V, 0.222 Ohm, Dual N-Channel, Logic Level UltraFET Power MOSFET**

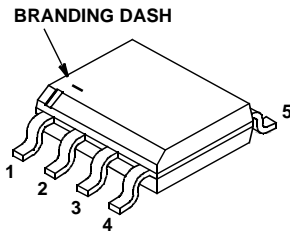

**Packaging**

JEDEC MS-012AA



**Symbol**

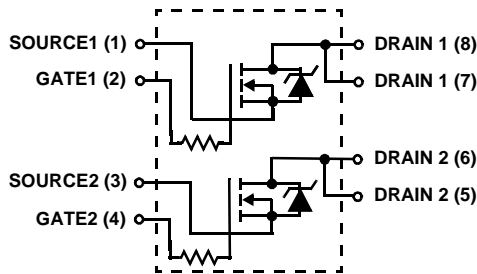

**Features**

- Ultra Low On-Resistance
  - $r_{DS(ON)} = 0.200\Omega, V_{GS} = 10V$
  - $r_{DS(ON)} = 0.222\Omega, V_{GS} = 5V$
- Simulation Models
  - Temperature Compensated PSPICE™ and SABER Electrical Models
  - Spice and SABER Thermal Impedance Models
  - www.Fairchildsemi.com
- Internal  $R_G = 50\Omega$
- Peak Current vs Pulse Width Curve
- UIS Rating Curve
- Transient Thermal Impedance Curve vs Board Mounting Area

**Ordering Information**

PART NUMBER	PACKAGE	BRAND
HUFA76504DK8	MS-012AA	76504DK8

NOTE: When ordering, use the entire part number. Add the suffix T to obtain the variant in tape and reel, e.g., HUFA76504DK8T.

**Absolute Maximum Ratings**  $T_A = 25^\circ C$ , Unless Otherwise Specified

	HUFA76504DK8	UNITS
Drain to Source Voltage (Note 1).....	$V_{DSS}$	80 V
Drain to Gate Voltage ( $R_{GS} = 20k\Omega$ ) (Note 1).....	$V_{DGR}$	80 V
Gate to Source Voltage.....	$V_{GS}$	$\pm 16$ V
Drain Current		
Continuous ( $T_A = 25^\circ C, V_{GS} = 5V$ ) (Note 2).....	$I_D$	2.3 A
Continuous ( $T_A = 25^\circ C, V_{GS} = 10V$ ) (Figure 2) (Note 2).....	$I_D$	2.5 A
Continuous ( $T_A = 100^\circ C, V_{GS} = 5V$ ) (Note 3).....	$I_D$	1.1 A
Continuous ( $T_A = 100^\circ C, V_{GS} = 4.5V$ ) (Figure 2) (Note 3).....	$I_D$	1.1 A
Pulsed Drain Current.....	$I_{DM}$	Figure 4
Pulsed Avalanche Rating.....	UIS	Figures 6, 17, 18
Power Dissipation (Note 2).....	$P_D$	2.5 W
Derate Above $25^\circ C$ .....		20 mW/ $^\circ C$
Operating and Storage Temperature.....	$T_J, T_{STG}$	-55 to 150 $^\circ C$
Maximum Temperature for Soldering		
Leads at 0.063in (1.6mm) from Case for 10s.....	$T_L$	300 $^\circ C$
Package Body for 10s, See Techbrief TB334.....	$T_{pkg}$	260 $^\circ C$

NOTES:

1.  $T_J = 25^\circ C$  to  $125^\circ C$ .
2. 50°C/W measured using FR-4 board with 0.76 in<sup>2</sup> (490.3 mm<sup>2</sup>) copper pad at 1 second.
3. 228°C/W measured using FR-4 board with 0.006 in<sup>2</sup> (3.87 mm<sup>2</sup>) copper pad at 1000 seconds.

**CAUTION:** Stresses above those listed in "Absolute Maximum Ratings" may cause permanent damage to the device. This is a stress only rating and operation of the device at these or any other conditions above those indicated in the operational sections of this specification is not implied.

This product has been designed to meet the extreme test conditions and environment demanded by the automotive industry. For a copy of the requirements, see AEC Q101 at: <http://www.aecouncil.com/>

Reliability data can be found at: <http://www.mtp.intersil.com/automotive.html>.

All Fairchild semiconductor products are manufactured, assembled and tested under ISO9000 and QS9000 quality systems certification.

# HUFA76504DK8

## Electrical Specifications $T_A = 25^\circ\text{C}$ , Unless Otherwise Specified

PARAMETER	SYMBOL	TEST CONDITIONS	MIN	TYP	MAX	UNITS	
<b>OFF STATE SPECIFICATIONS</b>							
Drain to Source Breakdown Voltage	$BV_{DSS}$	$I_D = 250\mu\text{A}$ , $V_{GS} = 0\text{V}$ (Figure 12)	80	-	-	V	
		$I_D = 250\mu\text{A}$ , $V_{GS} = 0\text{V}$ , $T_A = -40^\circ\text{C}$ (Figure 12)	70	-	-	V	
Zero Gate Voltage Drain Current	$I_{DSS}$	$V_{DS} = 75\text{V}$ , $V_{GS} = 0\text{V}$	-	-	1	$\mu\text{A}$	
		$V_{DS} = 70\text{V}$ , $V_{GS} = 0\text{V}$ , $T_A = 150^\circ\text{C}$	-	-	250	$\mu\text{A}$	
Gate to Source Leakage Current	$I_{GSS}$	$V_{GS} = \pm 16\text{V}$	-	-	$\pm 100$	nA	
<b>ON STATE SPECIFICATIONS</b>							
Gate to Source Threshold Voltage	$V_{GS(TH)}$	$V_{GS} = V_{DS}$ , $I_D = 250\mu\text{A}$ (Figure 11)	1	-	3	V	
Drain to Source On Resistance	$r_{DS(ON)}$	$I_D = 2.5\text{A}$ , $V_{GS} = 10\text{V}$ (Figures 9, 10)	-	0.173	0.200	$\Omega$	
		$I_D = 1.1\text{A}$ , $V_{GS} = 5\text{V}$ (Figure 9)	-	0.193	0.222	$\Omega$	
		$I_D = 1.1\text{A}$ , $V_{GS} = 4.5\text{V}$ (Figure 9)	-	0.200	0.230	$\Omega$	
<b>THERMAL SPECIFICATIONS</b>							
Thermal Resistance Junction to Lead	$R_{\theta JL}$		-	-	25	$^\circ\text{C/W}$	
Thermal Resistance Junction to Ambient	$R_{\theta JA}$	Pad Area = $0.50\text{ in}^2$ ( $323\text{ mm}^2$ ) (Note 2)	-	-	50	$^\circ\text{C/W}$	
		Pad Area = $0.027\text{ in}^2$ ( $17.4\text{ mm}^2$ ) (Figure 23)	-	-	191	$^\circ\text{C/W}$	
		Pad Area = $0.006\text{ in}^2$ ( $3.87\text{ mm}^2$ ) (Figure 23)	-	-	228	$^\circ\text{C/W}$	
<b>SWITCHING SPECIFICATIONS (<math>V_{GS} = 4.5\text{V}</math>)</b>							
Turn-On Time	$t_{ON}$	$V_{DD} = 40\text{V}$ , $I_D = 1.1\text{A}$ $V_{GS} = 4.5\text{V}$ , $R_{GS} = 43\Omega$ (Figures 15, 21, 22)	-	-	100	ns	
Turn-On Delay Time	$t_{d(ON)}$		-	27	-	ns	
Rise Time	$t_r$		-	40	-	ns	
Turn-Off Delay Time	$t_{d(OFF)}$		-	73	-	ns	
Fall Time	$t_f$		-	31	-	ns	
Turn-Off Time	$t_{OFF}$		-	-	160	ns	
<b>SWITCHING SPECIFICATIONS (<math>V_{GS} = 10\text{V}</math>)</b>							
Turn-On Time	$t_{ON}$	$V_{DD} = 40\text{V}$ , $I_D = 2.5\text{A}$ $V_{GS} = 10\text{V}$ , $R_{GS} = 47\Omega$ (Figures 16, 21, 22)	-	-	41	ns	
Turn-On Delay Time	$t_{d(ON)}$		-	10	-	ns	
Rise Time	$t_r$		-	18	-	ns	
Turn-Off Delay Time	$t_{d(OFF)}$		-	115	-	ns	
Fall Time	$t_f$		-	36	-	ns	
Turn-Off Time	$t_{OFF}$		-	-	230	ns	
<b>GATE CHARGE SPECIFICATIONS</b>							
Total Gate Charge	$Q_{g(TOT)}$	$V_{GS} = 0\text{V to } 10\text{V}$	$V_{DD} = 40\text{V}$ , $I_D = 1.1\text{A}$ , $I_{g(REF)} = 1.0\text{mA}$ (Figures 14, 19, 20)	-	6.6	10	nC
Gate Charge at 5V	$Q_{g(5)}$	$V_{GS} = 0\text{V to } 5\text{V}$		-	3.4	5.4	nC
Threshold Gate Charge	$Q_{g(TH)}$	$V_{GS} = 0\text{V to } 1\text{V}$		-	0.3	0.5	nC
Gate to Source Gate Charge	$Q_{gs}$			-	0.8	-	nC
Gate to Drain "Miller" Charge	$Q_{gd}$			-	1.4	-	nC
<b>CAPACITANCE SPECIFICATIONS</b>							
Input Capacitance	$C_{ISS}$	$V_{DS} = 25\text{V}$ , $V_{GS} = 0\text{V}$ , $f = 1\text{MHz}$ (Figure 13)	-	270	-	pF	
Output Capacitance	$C_{OSS}$		-	62	-	pF	
Reverse Transfer Capacitance	$C_{RSS}$		-	11	-	pF	

## Source to Drain Diode Specifications

PARAMETER	SYMBOL	TEST CONDITIONS	MIN	TYP	MAX	UNITS
Source to Drain Diode Voltage	$V_{SD}$	$I_{SD} = 1.1\text{A}$	-	-	1.25	V
		$I_{SD} = 0.7\text{A}$	-	-	1.00	V
Reverse Recovery Time	$t_{rr}$	$I_{SD} = 5.0\text{A}$ , $dI_{SD}/dt = 100\text{A}/\mu\text{s}$	-	-	62	ns
Reverse Recovered Charge	$Q_{RR}$	$I_{SD} = 5.0\text{A}$ , $dI_{SD}/dt = 100\text{A}/\mu\text{s}$	-	-	115	nC

Typical Performance Curves

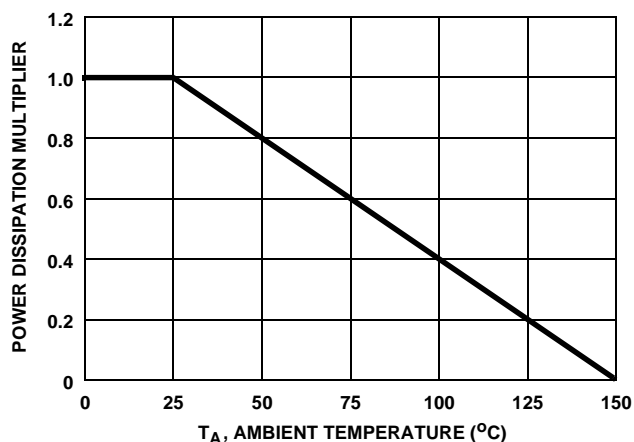

FIGURE 1. NORMALIZED POWER DISSIPATION vs AMBIENT TEMPERATURE

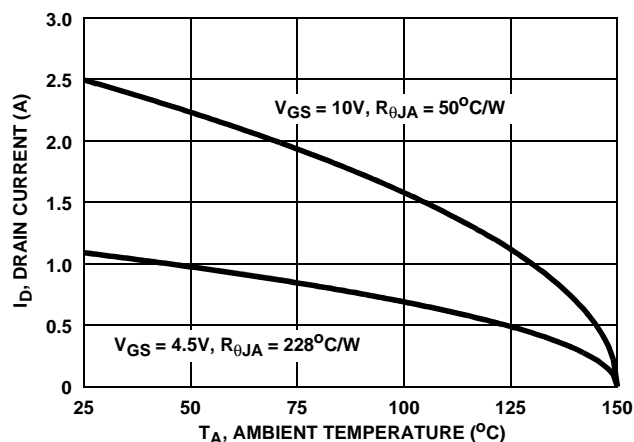

FIGURE 2. MAXIMUM CONTINUOUS DRAIN CURRENT vs AMBIENT TEMPERATURE

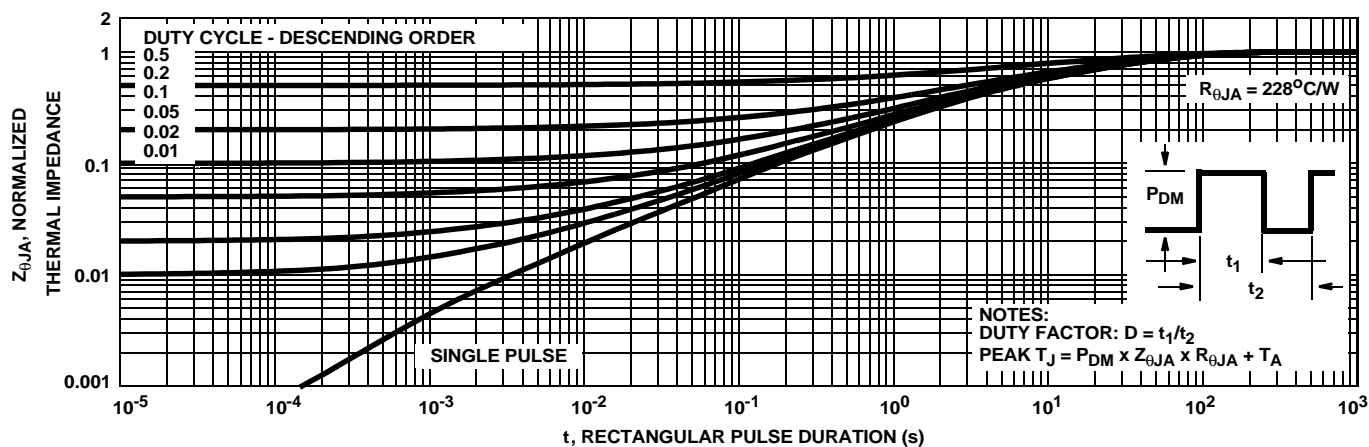

FIGURE 3. NORMALIZED MAXIMUM TRANSIENT THERMAL IMPEDANCE

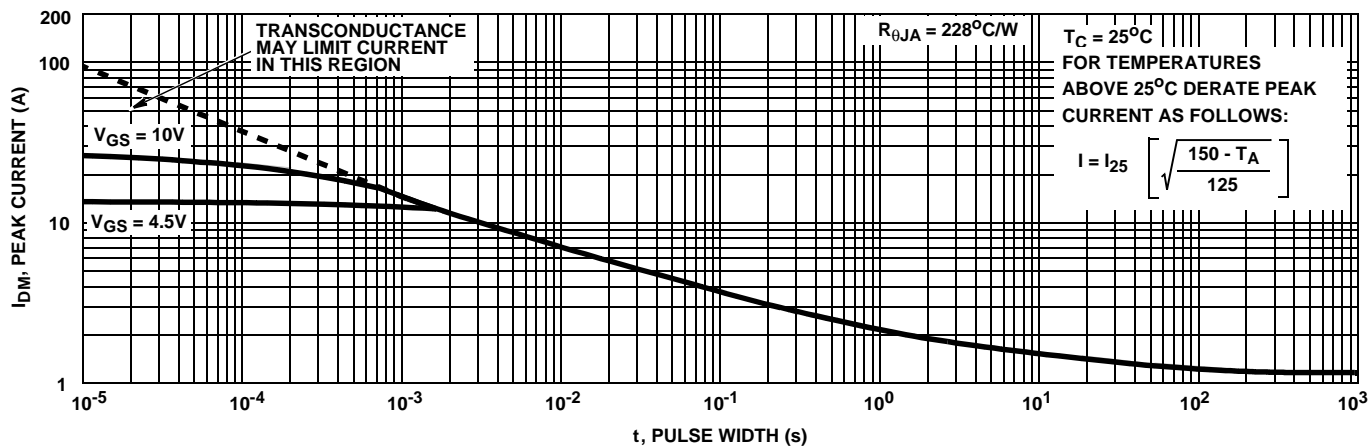

FIGURE 4. PEAK CURRENT CAPABILITY

Typical Performance Curves (Continued)

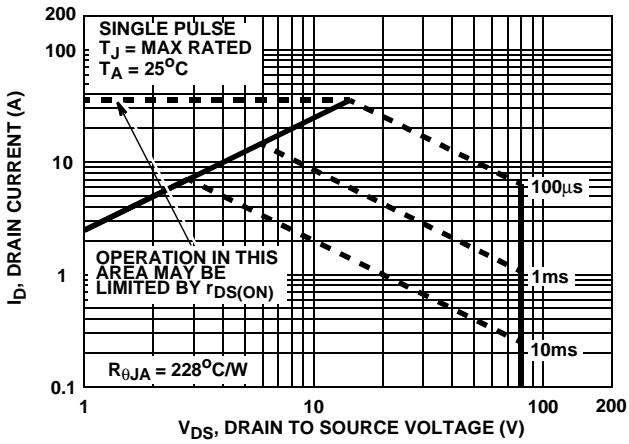
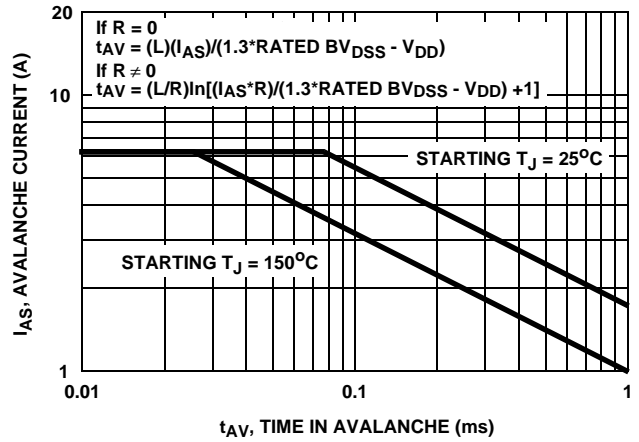

FIGURE 5. FORWARD BIAS SAFE OPERATING AREA



NOTE: Refer to Application Notes AN9321 and AN9322.

FIGURE 6. UNCLAMPED INDUCTIVE SWITCHING CAPABILITY

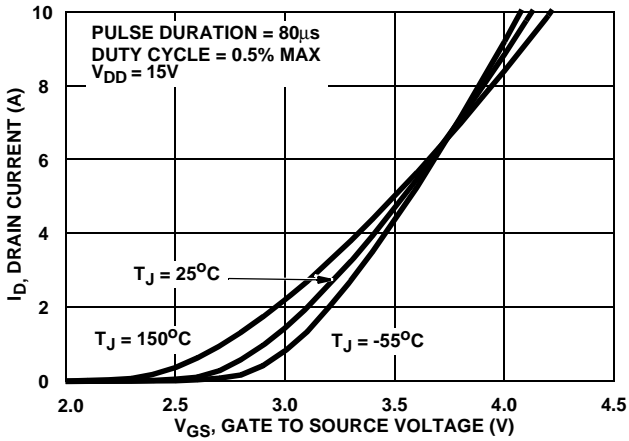

FIGURE 7. TRANSFER CHARACTERISTICS

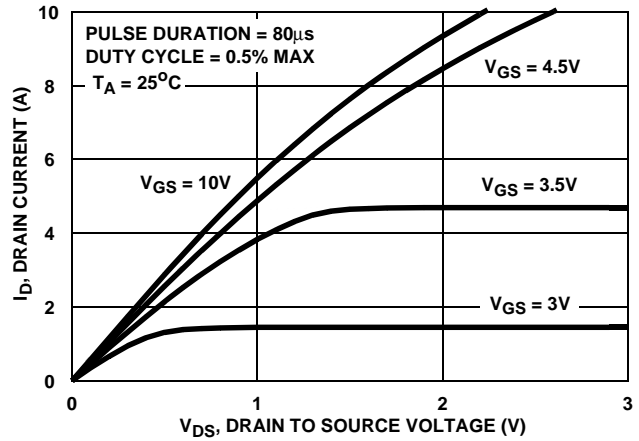

FIGURE 8. SATURATION CHARACTERISTICS

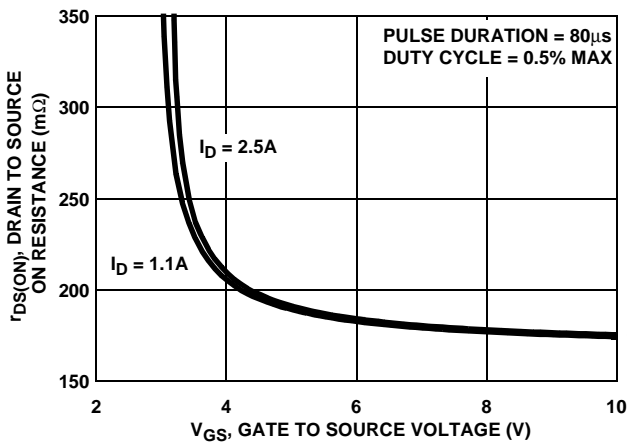

FIGURE 9. DRAIN TO SOURCE ON RESISTANCE vs. GATE VOLTAGE AND DRAIN CURRENT

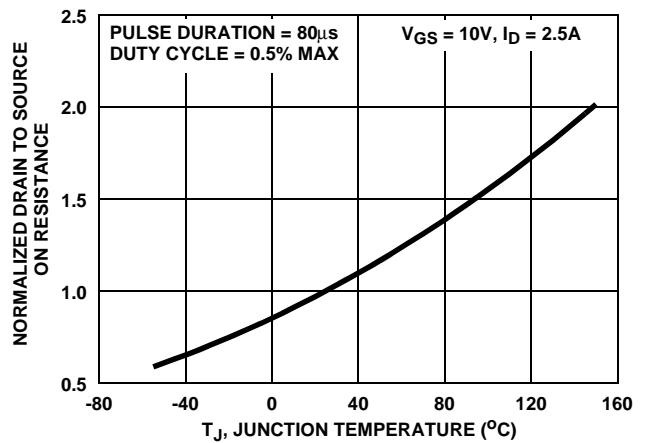

FIGURE 10. NORMALIZED DRAIN TO SOURCE ON RESISTANCE vs. JUNCTION TEMPERATURE

Typical Performance Curves (Continued)

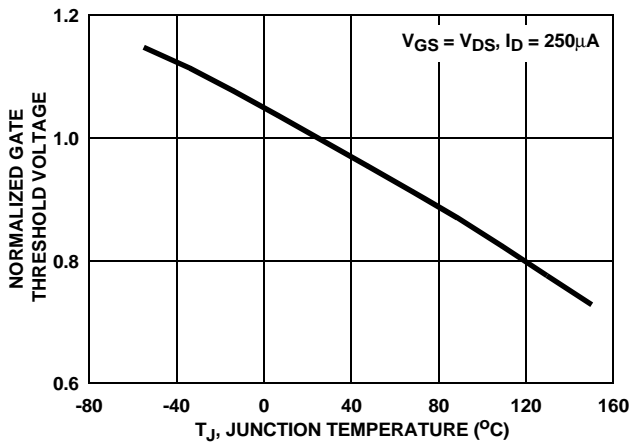

FIGURE 11. NORMALIZED GATE THRESHOLD VOLTAGE vs JUNCTION TEMPERATURE

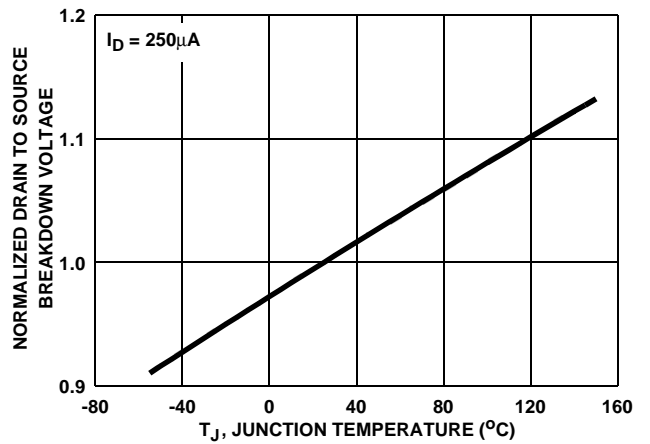

FIGURE 12. NORMALIZED DRAIN TO SOURCE BREAKDOWN VOLTAGE vs JUNCTION TEMPERATURE

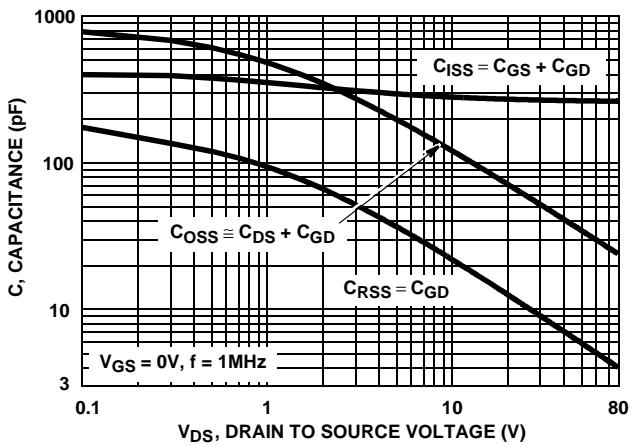
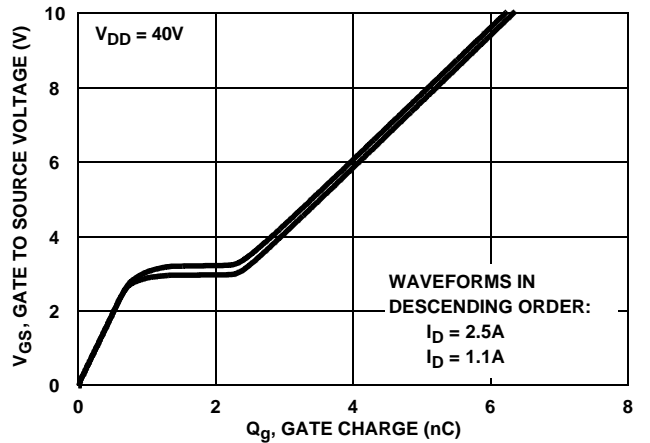

FIGURE 13. CAPACITANCE vs DRAIN TO SOURCE VOLTAGE



NOTE: Refer to Application Notes AN7254 and AN7260.

FIGURE 14. GATE CHARGE WAVEFORMS FOR CONSTANT GATE CURRENT

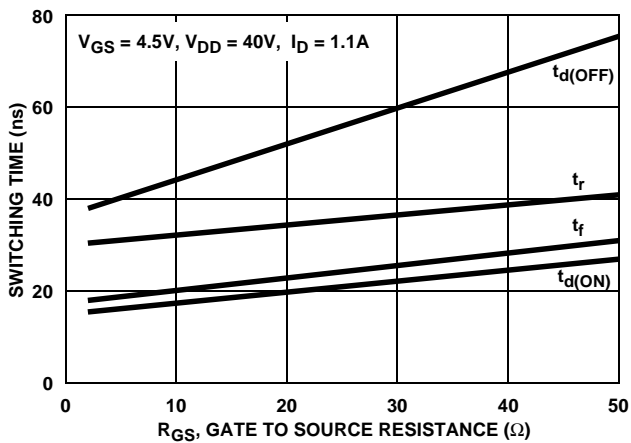

FIGURE 15. SWITCHING TIME vs GATE RESISTANCE

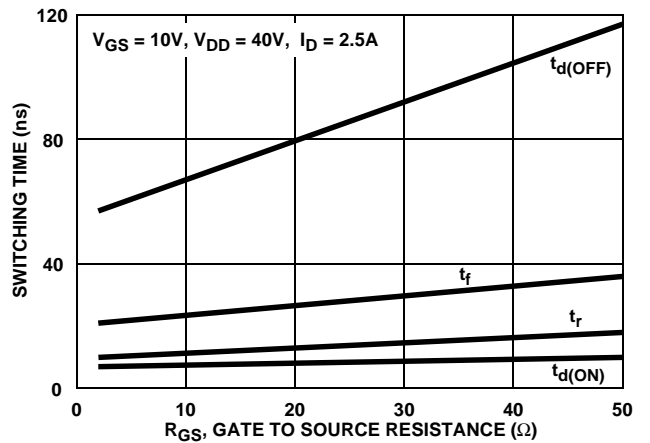

FIGURE 16. SWITCHING TIME vs GATE RESISTANCE

Test Circuits and Waveforms

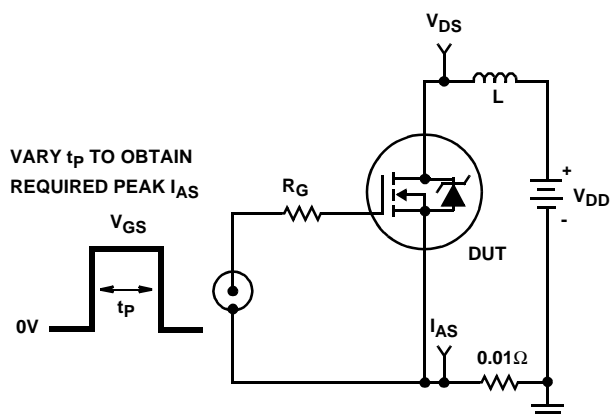

FIGURE 17. UNCLAMPED ENERGY TEST CIRCUIT

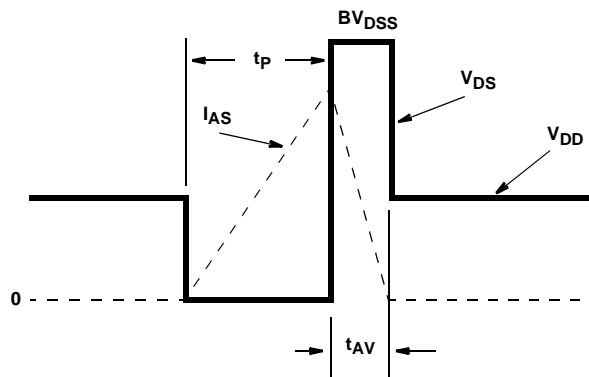

FIGURE 18. UNCLAMPED ENERGY WAVEFORMS

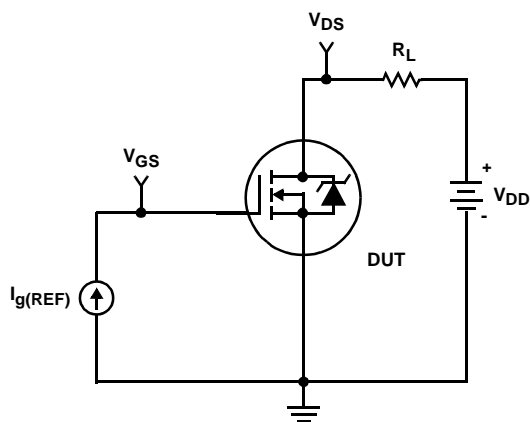

FIGURE 19. GATE CHARGE TEST CIRCUIT

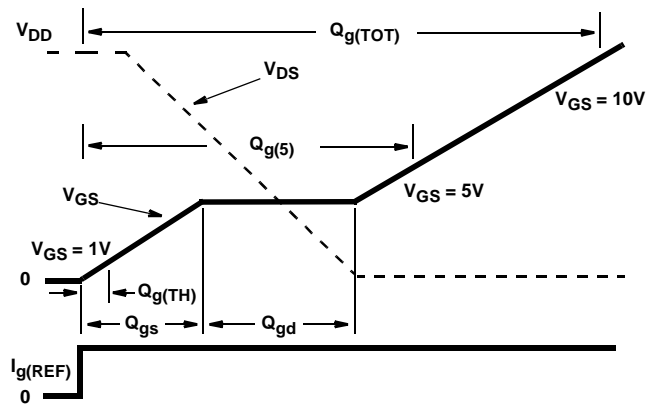

FIGURE 20. GATE CHARGE WAVEFORMS

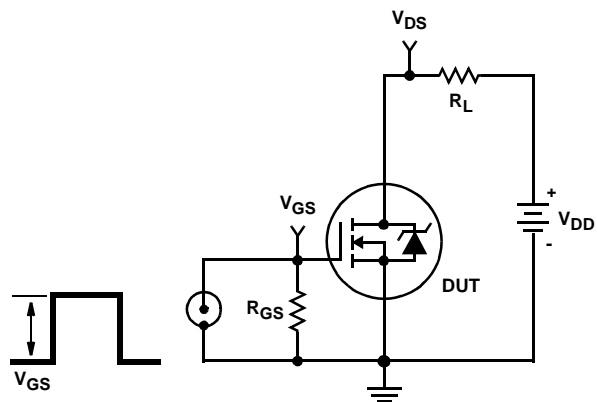

FIGURE 21. SWITCHING TIME TEST CIRCUIT

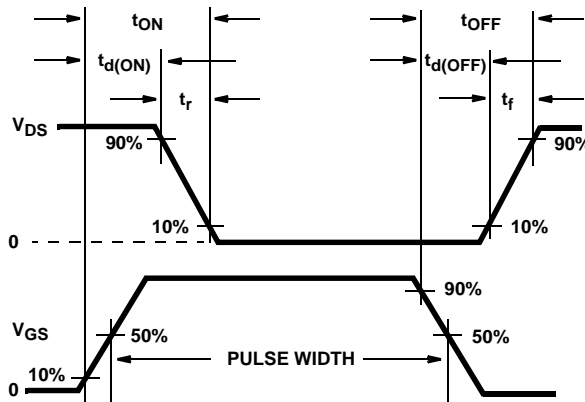

FIGURE 22. SWITCHING TIME WAVEFORM

### Thermal Resistance vs. Mounting Pad Area

The maximum rated junction temperature,  $T_{JM}$ , and the thermal resistance of the heat dissipating path determines the maximum allowable device power dissipation,  $P_{DM}$ , in an application. Therefore the application's ambient temperature,  $T_A$  ( $^{\circ}C$ ), and thermal resistance  $R_{\theta JA}$  ( $^{\circ}C/W$ ) must be reviewed to ensure that  $T_{JM}$  is never exceeded. Equation 1 mathematically represents the relationship and serves as the basis for establishing the rating of the part.

$$P_{DM} = \frac{(T_{JM} - T_A)}{R_{\theta JA}} \quad (EQ. 1)$$

In using surface mount devices such as the SOP-8 package, the environment in which it is applied will have a significant influence on the part's current and maximum power dissipation ratings. Precise determination of  $P_{DM}$  is complex and influenced by many factors:

1. Mounting pad area onto which the device is attached and whether there is copper on one side or both sides of the board.
2. The number of copper layers and the thickness of the board.
3. The use of external heat sinks.
4. The use of thermal vias.
5. Air flow and board orientation.
6. For non steady state applications, the pulse width, the duty cycle and the transient thermal response of the part, the board and the environment they are in.

Fairchild provides thermal information to assist the designer's preliminary application evaluation. Figure 23 defines the  $R_{\theta JA}$  for the device as a function of the top copper (component side) area. This is for a horizontally positioned FR-4 board with 1oz copper after 1000 seconds of steady state power with no air flow. This graph provides the necessary information for calculation of the steady state junction temperature or power dissipation. Pulse applications can be evaluated using the Fairchild device Spice thermal model or manually utilizing the normalized maximum transient thermal impedance curve.

Displayed on the curve are  $R_{\theta JA}$  values listed in the Electrical Specifications table. The points were chosen to depict the compromise between the copper board area, the thermal resistance and ultimately the power dissipation,  $P_{DM}$ .

Thermal resistances corresponding to other copper areas can be obtained from Figure 23 or by calculation using Equation 2.  $R_{\theta JA}$  is defined as the natural log of the area times a coefficient added to a constant. The area, in square inches is the top copper area including the gate and source pads.

$$R_{\theta JA} = 103.2 - 24.3 \times \ln(\text{Area}) \quad (EQ. 2)$$

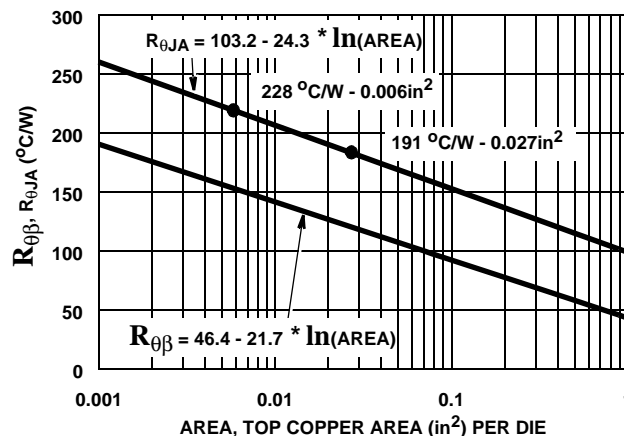

FIGURE 23. THERMAL RESISTANCE vs MOUNTING PAD AREA

While Equation 2 describes the thermal resistance of a single die, several of the new UltraFET™s are offered with two die in the SOP-8 package. The dual die SOP-8 package introduces an additional thermal component, thermal coupling resistance,  $R_{\theta\beta}$ . Equation 3 describes  $R_{\theta\beta}$  as a function of the top copper mounting pad area.

$$R_{\theta\beta} = 46.4 - 21.7 \times \ln(\text{Area}) \quad (EQ. 3)$$

The thermal coupling resistance vs. copper area is also graphically depicted in Figure 23. It is important to note the thermal resistance ( $R_{\theta JA}$ ) and thermal coupling resistance ( $R_{\theta\beta}$ ) are equivalent for both die. For example at 0.1 square inches of copper:

$$R_{\theta JA1} = R_{\theta JA2} = 159^{\circ}C/W$$

$$R_{\theta\beta1} = R_{\theta\beta2} = 97^{\circ}C/W$$

$T_{J1}$  and  $T_{J2}$  define the junction temperature of the respective die. Similarly,  $P_1$  and  $P_2$  define the power dissipated in each die. The steady state junction temperature can be calculated using Equation 4 for die 1 and Equation 5 for die 2.

Example: To calculate the junction temperature of each die when die 2 is dissipating 0.5 Watts and die 1 is dissipating 0 Watts. The ambient temperature is  $70^{\circ}C$  and the package is mounted to a top copper area of 0.1 square inches per die. Use Equation 4 to calculate  $T_{J1}$  and Equation 5 to calculate  $T_{J2}$ .

$$T_{J1} = P_1 R_{\theta JA} + P_2 R_{\theta\beta} + T_A \quad (EQ. 4)$$

$$T_{J1} = (0 \text{ Watts})(159^{\circ}C/W) + (0.5 \text{ Watts})(97^{\circ}C/W) + 70^{\circ}C$$

$$T_{J1} = 119^{\circ}C$$

$$T_{J2} = P_2 R_{\theta JA} + P_1 R_{\theta\beta} + T_A \quad (EQ. 5)$$

$$T_{J2} = (0.5 \text{ Watts})(159^{\circ}C/W) + (0 \text{ Watts})(97^{\circ}C/W) + 70^{\circ}C$$

$$T_{J2} = 150^{\circ}C$$

## HUFA76504DK8

The transient thermal impedance ( $Z_{\theta JA}$ ) is also effected by varied top copper board area. Figure 24 shows the effect of copper pad area on single pulse transient thermal impedance. Each trace represents a copper pad area in square inches corresponding to the descending list in the graph. Spice and SABER thermal models are provided for each of the listed pad areas.

Copper pad area has no perceivable effect on transient thermal impedance for pulse widths less than 100ms. For pulse widths less than 100ms the transient thermal impedance is determined by the die and package. Therefore, C THERM1 through C THERM5 and R THERM1 through R THERM5 remain constant for each of the thermal models. A listing of the model component values is available in Table 1.

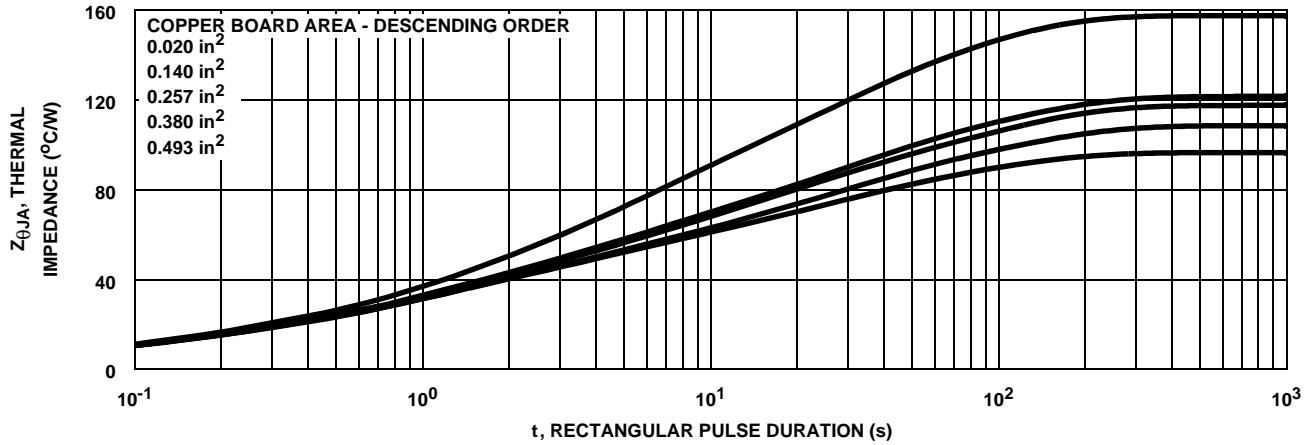

FIGURE 24. THERMAL RESISTANCE vs MOUNTING PAD AREA

**PSPICE Electrical Model**

.SUBCKT HUFA76504DK8 2 1 3 ; REV 18 January 2001

CA 12 8 2.5e-10  
 CB 15 14 3e-10  
 CIN 6 8 2.6e-10

DBODY 7 5 DBODYMOD  
 DBREAK 5 11 DBREAKMOD  
 DPLCAP 10 5 DPLCAPMOD

EBREAK 11 7 17 18 100.6  
 EDS 14 8 5 8 1  
 EGS 13 8 6 8 1  
 ESG 6 10 6 8 1  
 EVTHRES 6 21 19 8 1  
 EVTEMP 20 6 18 22 1

IT 8 17 1

LDRAIN 2 5 1.0e-9  
 LGATE 1 9 4.21e-10  
 LSOURCE 3 7 1.28e-10

MMED 16 6 8 8 MMEDMOD  
 MSTRO 16 6 8 8 MSTROMOD  
 MWEAK 16 21 8 8 MWEAKMOD

RBREAK 17 18 RBREAKMOD 1  
 RDRAIN 50 16 RDRAINMOD 1.1e-1  
 RGATE 9 20 5.74e1  
 RLDRAIN 2 5 10  
 RLGATE 1 9 42.1  
 RLSOURCE 3 7 12.8  
 RSLC1 5 51 RSLCMOD 1e-6  
 RSLC2 5 50 1e3  
 RSOURCE 8 7 RSOURCEMOD 5.72e-2  
 RVTHRES 22 8 RVTHRESMOD 1  
 RVTEMP 18 19 RVTEMPMOD 1

S1A 6 12 13 8 S1AMOD  
 S1B 13 12 13 8 S1BMOD  
 S2A 6 15 14 13 S2AMOD  
 S2B 13 15 14 13 S2BMOD

VBAT 22 19 DC 1

ESLC 51 50 VALUE={(V(5,51)/ABS(V(5,51)))\*(PWR(V(5,51)/(1e-6\*12),3.7))}

.MODEL DBODYMOD D (IS = 3.1e-13 N = 1.03 RS = 4.2e-2 TRS1 = 3e-4 TRS2 = 1.3e-6 CJO = 6.82e-10 TT = 3.3e-8 M = 0.8 XTI = 4)  
 .MODEL DBREAKMOD D (RS = 1.65 TRS1 = 1e-3 TRS2 = -9e-6)  
 .MODEL DPLCAPMOD D (CJO = 1.7e-10 IS = 1e-30 M = 0.85)  
 .MODEL MMEDMOD NMOS (VTO = 2.2 KP = 1.1 IS = 1e-30 N = 10 TOX = 1 L = 1u W = 1u RG = 5.74e1)  
 .MODEL MSTROMOD NMOS (VTO = 2.56 KP = 18 IS = 1e-30 N = 10 TOX = 1 L = 1u W = 1u)  
 .MODEL MWEAKMOD NMOS (VTO = 1.94 KP = 0.04 IS = 1e-30 N = 10 TOX = 1 L = 1u W = 1u RG = 5.74e2 RS = 0.1)  
 .MODEL RBREAKMOD RES (TC1 = 1.12e-3 TC2 = -3e-7)  
 .MODEL RDRAINMOD RES (TC1 = 9e-3 TC2 = 2e-5)  
 .MODEL RSLCMOD RES (TC1 = 2.8e-3 TC2 = 1.9e-5)  
 .MODEL RSOURCEMOD RES (TC1 = 1e-3 TC2 = 1e-6)  
 .MODEL RVTHRESMOD RES (TC1 = -2e-3 TC2 = -3e-6)  
 .MODEL RVTEMPMOD RES (TC1 = -1.5e-3 TC2 = 1e-6)

.MODEL S1AMOD VSWITCH (RON = 1e-5 ROFF = 0.1 VON = -4 VOFF = -1)  
 .MODEL S1BMOD VSWITCH (RON = 1e-5 ROFF = 0.1 VON = -1 VOFF = -4)  
 .MODEL S2AMOD VSWITCH (RON = 1e-5 ROFF = 0.1 VON = -0.5 VOFF = 0.5)  
 .MODEL S2BMOD VSWITCH (RON = 1e-5 ROFF = 0.1 VON = 0.5 VOFF = -0.5)

.ENDS

NOTE: For further discussion of the PSPICE model, consult **A New PSPICE Sub-Circuit for the Power MOSFET Featuring Global Temperature Options**; IEEE Power Electronics Specialist Conference Records, 1991, written by William J. Hepp and C. Frank Wheatley.

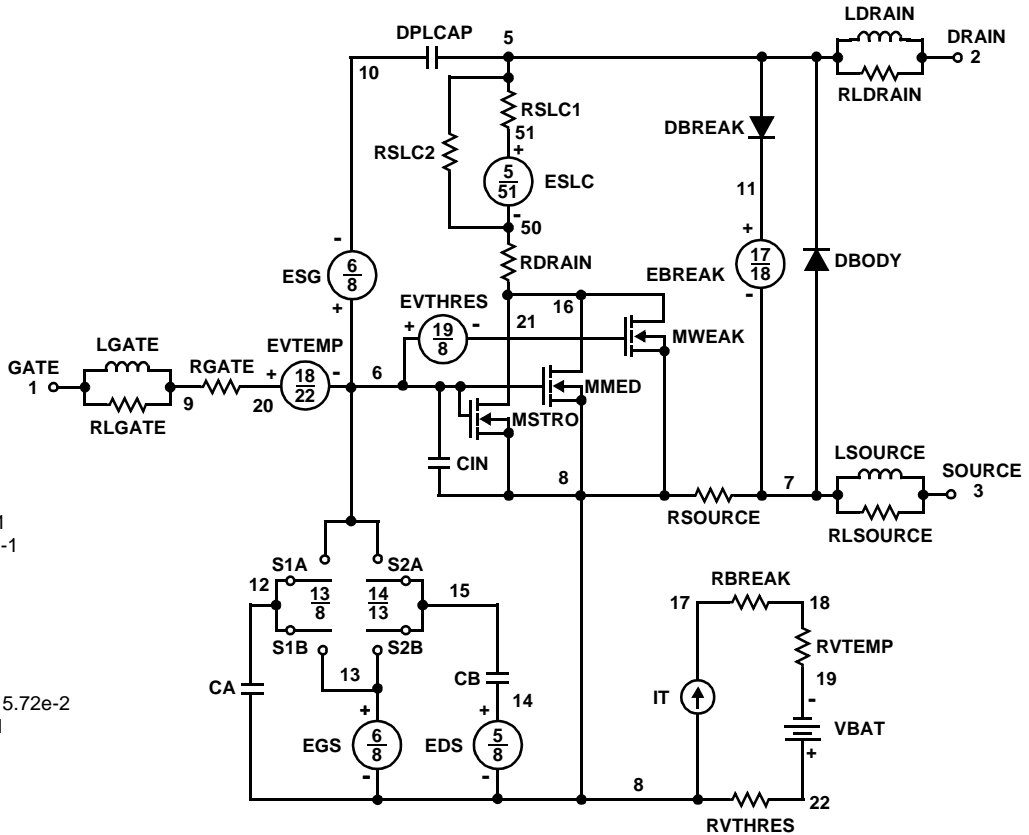

**SABER Electrical Model**

REV 18 January 2001

template HUFA76504dk8 n2,n1,n3  
electrical n2,n1,n3

```
{
var i iscl
dp..model dbodymod = (is = 3.1e-13, n1 = 1.03, rs = 4.2e-2, trs1 = 3e-4, trs2 = 1.3e-6, cjo = 6.82e-10, tt = 3.38e-8, m = 0.8, xti = 4)
dp..model dbreakmod = (rs = 1.65, trs1 = 1e-3, trs2 = -9e-6)
dp..model dplcapmod = (cjo = 1.7e-10, isl = 10e-30, n1 = 10, m = 0.85)
m..model mmedmod = (type=_n, vto = 2.2, kp = 1.1, is = 1e-30, tox = 1)
m..model mstrongmod = (type=_n, vto = 2.56, kp = 18, is = 1e-30, tox = 1)
m..model mweakmod = (type=_n, vto = 1.94, kp = 0.04, is = 1e-30, tox = 1, rs = .1)
sw_vcsp..model s1amod = (ron = 1e-5, roff = 0.1, von = -4, voff = -1)
sw_vcsp..model s1bmod = (ron = 1e-5, roff = 0.1, von = -1, voff = -4)
sw_vcsp..model s2amod = (ron = 1e-5, roff = 0.1, von = -0.5, voff = 0.5)
sw_vcsp..model s2bmod = (ron = 1e-5, roff = 0.1, von = 0.5, voff = -0.5)
```

```
c.ca n12 n8 = 2.5e-10
c.cb n15 n14 = 3e-10
c.cin n6 n8 = 2.6e-10
```

```
dp.dbody n7 n71 = model=dbodymod
dp.dbreak n72 n11 = model=dbreakmod
dp.dplcap n10 n5 = model=dplcapmod
```

```
i.it n8 n17 = 1
```

```
l.l drain n2 n5 = 1e-9
l.l gate n1 n9 = 4.21e-10
l.l source n3 n7 = 1.28e-10
```

```
m.mmed n16 n6 n8 n8 = model=mmedmod, l=1u, w=1u
m.mstrong n16 n6 n8 n8 = model=mstrongmod, l=1u, w=1u
m.mweak n16 n21 n8 n8 = model=mweakmod, l=1u, w=1u
```

```
res.rbreak n17 n18 = 1, tc1 = 1.12e-3, tc2 = -3e-7
res.rdrain n50 n16 = 1.1e-1, tc1 = 9e-3, tc2 = 2e-5
res.rgate n9 n20 = 5.74e1
res.rldrain n2 n5 = 10
res.rlgate n1 n9 = 42.1
res.rlsource n3 n7 = 12.8
res.rslc1 n5 n51 = 1e-6, tc1 = 2.8e-3, tc2 = 1.9e-5
res.rslc2 n5 n50 = 1e3
res.rsources n8 n7 = 5.72e-2, tc1 = 1e-3, tc2 = 1e-6
res.rvtemp n18 n19 = 1, tc1 = -1.5e-3, tc2 = 1e-6
res.rvthres n22 n8 = 1, tc1 = -2e-3, tc2 = -3e-6
```

```
spe.ebreak n11 n7 n17 n18 = 100.6
spe.eds n14 n8 n5 n8 = 1
spe.egs n13 n8 n6 n8 = 1
spe.esg n6 n10 n6 n8 = 1
spe.evtemp n20 n6 n18 n22 = 1
spe.evthres n6 n21 n19 n8 = 1
```

```
sw_vcsp.s1a n6 n12 n13 n8 = model=s1amod
sw_vcsp.s1b n13 n12 n13 n8 = model=s1bmod
sw_vcsp.s2a n6 n15 n14 n13 = model=s2amod
sw_vcsp.s2b n13 n15 n14 n13 = model=s2bmod
```

```
v.vbat n22 n19 = dc=1
```

```
equations {
i (n51->n50) +=iscl
iscl: v(n51,n50) = ((v(n5,n51))/(1e-9+abs(v(n5,n51))))*(abs(v(n5,n51))*1e6/12)** 3.7))
}
}
```

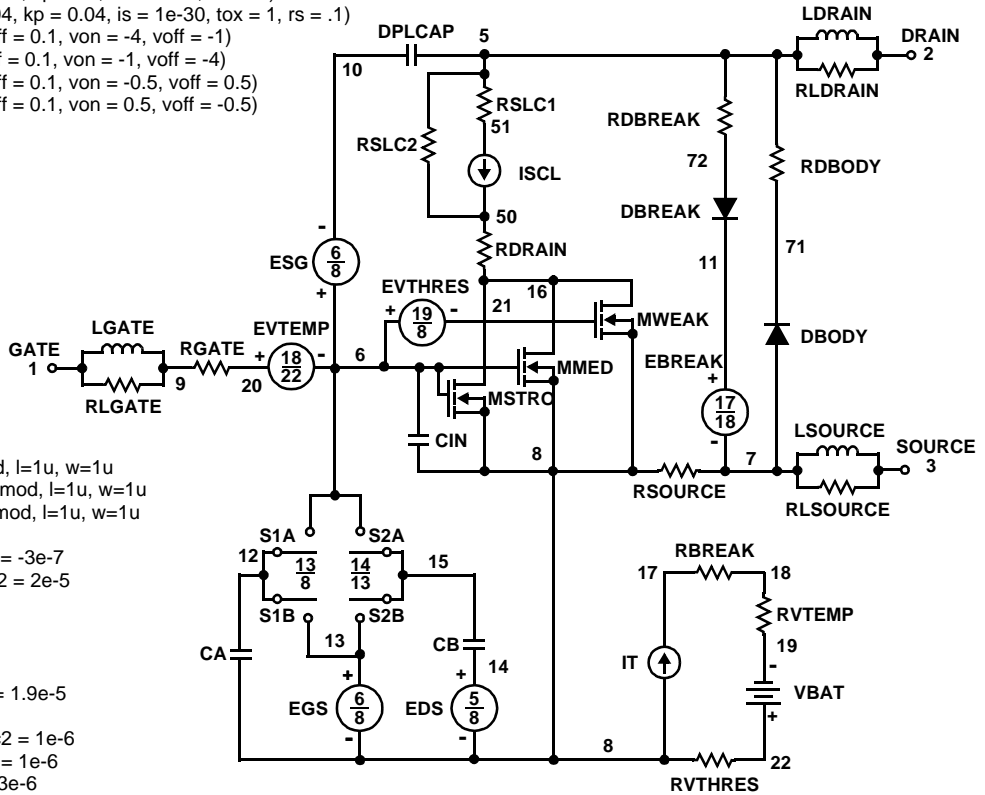

### SPICE Thermal Model

REV 18 January 2001  
 HUFA76504DK8  
 Copper Area = 0.38 in<sup>2</sup>  
 C THERM1 th 8 8.5e-4  
 C THERM2 8 7 1.8e-3  
 C THERM3 7 6 5.0e-3  
 C THERM4 6 5 1.3e-2  
 C THERM5 5 4 4.0e-2  
 C THERM6 4 3 1.5e-1  
 C THERM7 3 2 6.5e-1  
 C THERM8 2 tl 3.0

R THERM1 th 8 3.5e-2  
 R THERM2 8 7 6.0e-1  
 R THERM3 7 6 2  
 R THERM4 6 5 8  
 R THERM5 5 4 18  
 R THERM6 4 3 20  
 R THERM7 3 2 29  
 R THERM8 2 tl 31

### SABER Thermal Model

Copper Area = 0.38 in<sup>2</sup>  
 template thermal\_model th tl  
 thermal\_c th, tl  
 {  
 ctherm.ctherm1 th 8 = 8.5e-4  
 ctherm.ctherm2 8 7 = 1.8e-3  
 ctherm.ctherm3 7 6 = 5.0e-3  
 ctherm.ctherm4 6 5 = 1.3e-2  
 ctherm.ctherm5 5 4 = 4.0e-2  
 ctherm.ctherm6 4 3 = 1.5e-1  
 ctherm.ctherm7 3 2 = 6.5e-1  
 ctherm.ctherm8 2 tl = 3.0  
  
 rtherm.rtherm1 th 8 = 3.5e-2  
 rtherm.rtherm2 8 7 = 6.0e-1  
 rtherm.rtherm3 7 6 = 2  
 rtherm.rtherm4 6 5 = 8  
 rtherm.rtherm5 5 4 = 18  
 rtherm.rtherm6 4 3 = 20  
 rtherm.rtherm7 3 2 = 29  
 rtherm.rtherm8 2 tl = 31  
 }

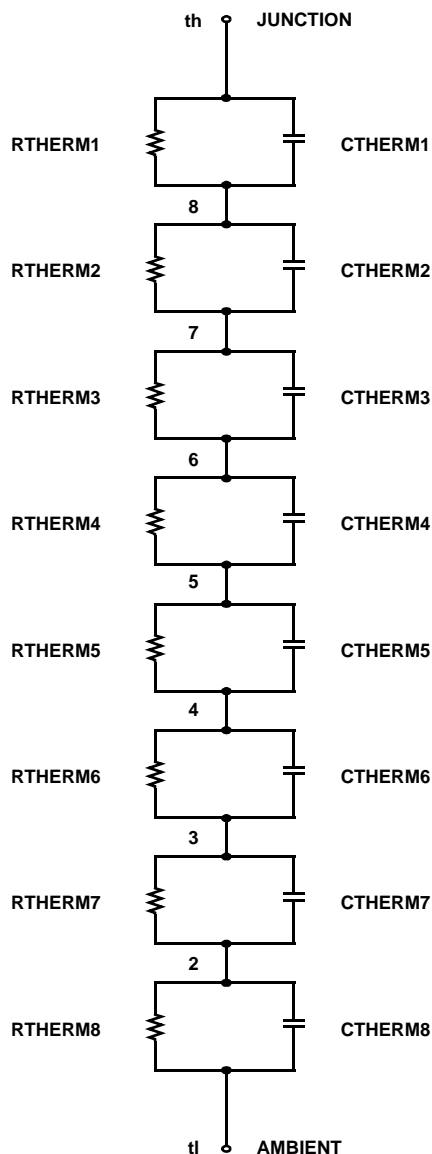

TABLE 1. Thermal Models

COMPONANT	0.02 in <sup>2</sup>	0.14 in <sup>2</sup>	0.257 in <sup>2</sup>	0.38 in <sup>2</sup>	0.493 in <sup>2</sup>
C THERM6	9.0e-2	1.3e-1	1.5e-1	1.5e-1	1.5e-1
C THERM7	4.0e-1	6.0e-1	4.5e-1	6.5e-1	7.5e-1
C THERM8	1.4	2.5	2.2	3	3
R THERM6	39	26	20	20	20
R THERM7	42	32	31	29	23
R THERM8	48	35	38	31	25

# MS-012AA

# HUFA76504DK8

## 8 LEAD JEDEC MS-012AA SMALL OUTLINE PLASTIC PACKAGE

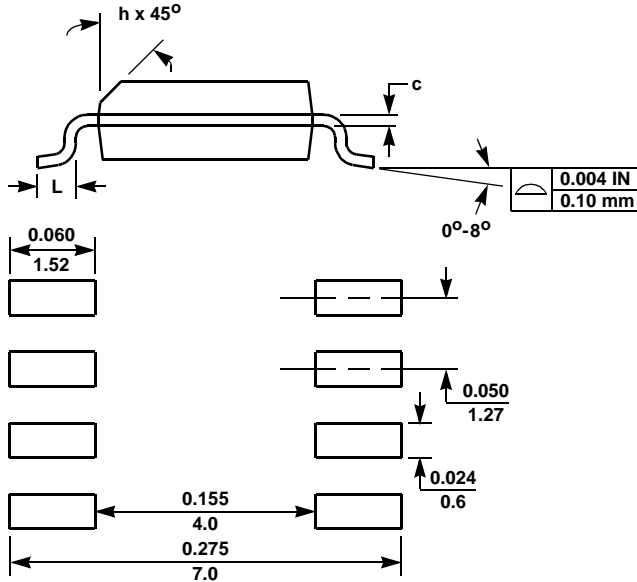
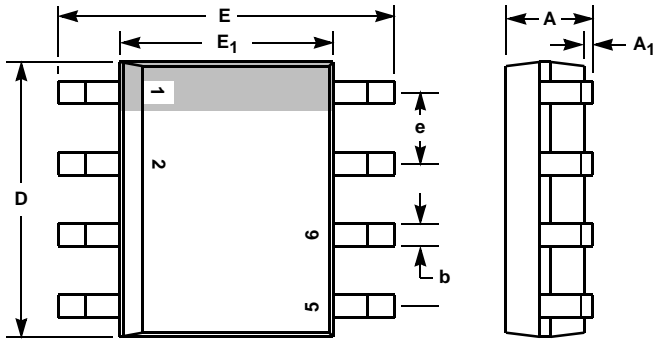

MINIMUM RECOMMENDED FOOTPRINT FOR SURFACE-MOUNTED APPLICATIONS

SYMBOL	INCHES		MILLIMETERS		NOTES
	MIN	MAX	MIN	MAX	
A	0.0532	0.0688	1.35	1.75	-
A <sub>1</sub>	0.004	0.0098	0.10	0.25	-
b	0.013	0.020	0.33	0.51	-
c	0.0075	0.0098	0.19	0.25	-
D	0.189	0.1968	4.80	5.00	2
E	0.2284	0.244	5.80	6.20	-
E <sub>1</sub>	0.1497	0.1574	3.80	4.00	3
e	0.050 BSC		1.27 BSC		-
H	0.0099	0.0196	0.25	0.50	-
L	0.016	0.050	0.40	1.27	4

NOTES:

1. All dimensions are within allowable dimensions of Rev. C of JEDEC MS-012AA outline dated 5-90.
2. Dimension "D" does not include mold flash, protrusions or gate burrs. Mold flash, protrusions or gate burrs shall not exceed 0.006 inches (0.15mm) per side.
3. Dimension "E<sub>1</sub>" does not include inter-lead flash or protrusions. Inter-lead flash and protrusions shall not exceed 0.010 inches (0.25mm) per side.
4. "L" is the length of terminal for soldering.
5. The chamfer on the body is optional. If it is not present, a visual index feature must be located within the crosshatched area.
6. Controlling dimension: Millimeter.
7. Revision 8 dated 5-99.

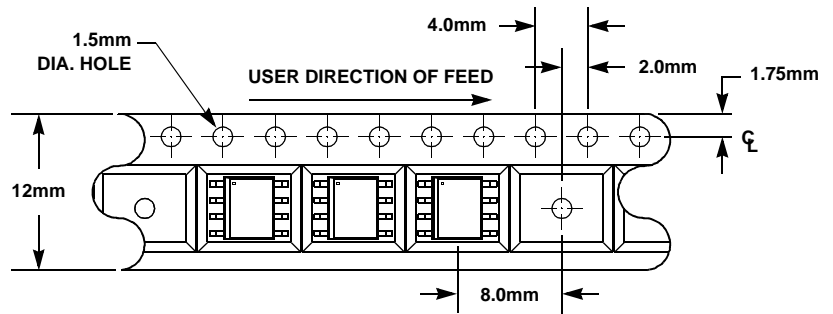

# MS-012AA

## 12mm TAPE AND REEL

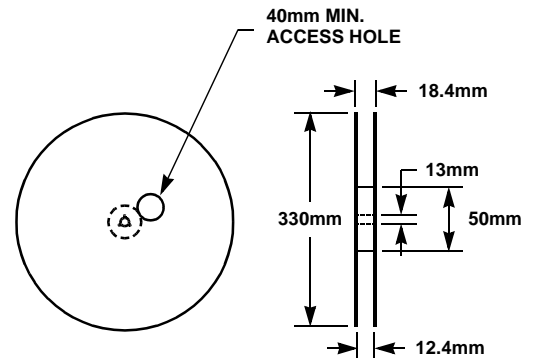
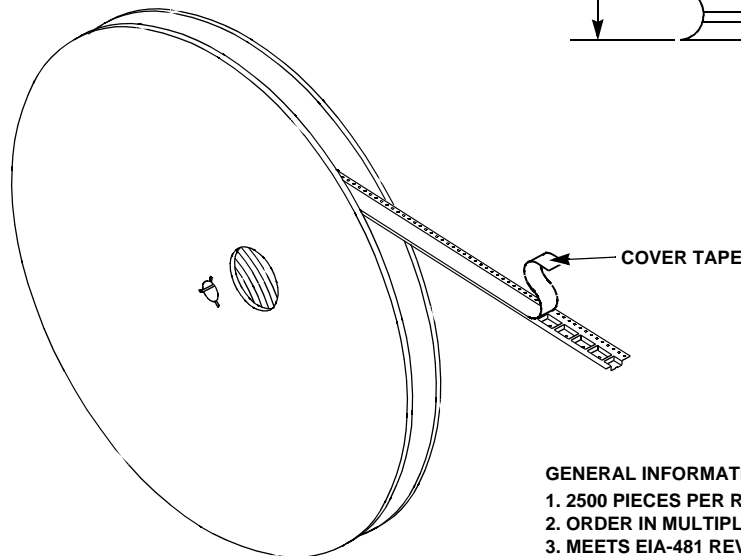

GENERAL INFORMATION

1. 2500 PIECES PER REEL.
2. ORDER IN MULTIPLES OF FULL REELS ONLY.
3. MEETS EIA-481 REVISION "A" SPECIFICATIONS.

## TRADEMARKS

The following are registered and unregistered trademarks Fairchild Semiconductor owns or is authorized to use and is not intended to be an exhaustive list of all such trademarks.

ACE <sub>x</sub> <sup>™</sup>	FAST <sup>®</sup>	OPTOPLANAR <sup>™</sup>	STAR*POWER <sup>™</sup>
Bottomless <sup>™</sup>	FAST <sub>r</sub> <sup>™</sup>	PACMAN <sup>™</sup>	Stealth <sup>™</sup>
CoolFET <sup>™</sup>	FRFET <sup>™</sup>	POP <sup>™</sup>	SuperSOT <sup>™</sup> -3
CROSSVOLT <sup>™</sup>	GlobalOptoisolator <sup>™</sup>	Power247 <sup>™</sup>	SuperSOT <sup>™</sup> -6
DenseTrench <sup>™</sup>	GTO <sup>™</sup>	PowerTrench <sup>®</sup>	SuperSOT <sup>™</sup> -8
DOME <sup>™</sup>	HiSeC <sup>™</sup>	QFET <sup>™</sup>	SyncFET <sup>™</sup>
EcoSPARK <sup>™</sup>	ISOPLANAR <sup>™</sup>	QS <sup>™</sup>	TinyLogic <sup>™</sup>
E <sup>2</sup> CMOS <sup>™</sup>	LittleFET <sup>™</sup>	QT Optoelectronics <sup>™</sup>	TruTranslation <sup>™</sup>
EnSigna <sup>™</sup>	MicroFET <sup>™</sup>	Quiet Series <sup>™</sup>	UHC <sup>™</sup>
FACT <sup>™</sup>	MICROWIRE <sup>™</sup>	SILENT SWITCHER <sup>®</sup>	UltraFET <sup>®</sup>
FACT Quiet Series <sup>™</sup>	OPTOLOGIC <sup>™</sup>	SMART START <sup>™</sup>	VCX <sup>™</sup>

STAR\*POWER is used under license

## DISCLAIMER

FAIRCHILD SEMICONDUCTOR RESERVES THE RIGHT TO MAKE CHANGES WITHOUT FURTHER NOTICE TO ANY PRODUCTS HEREIN TO IMPROVE RELIABILITY, FUNCTION OR DESIGN. FAIRCHILD DOES NOT ASSUME ANY LIABILITY ARISING OUT OF THE APPLICATION OR USE OF ANY PRODUCT OR CIRCUIT DESCRIBED HEREIN; NEITHER DOES IT CONVEY ANY LICENSE UNDER ITS PATENT RIGHTS, NOR THE RIGHTS OF OTHERS.

## LIFE SUPPORT POLICY

FAIRCHILD'S PRODUCTS ARE NOT AUTHORIZED FOR USE AS CRITICAL COMPONENTS IN LIFE SUPPORT DEVICES OR SYSTEMS WITHOUT THE EXPRESS WRITTEN APPROVAL OF FAIRCHILD SEMICONDUCTOR CORPORATION. As used herein:

1. Life support devices or systems are devices or systems which, (a) are intended for surgical implant into the body, or (b) support or sustain life, or (c) whose failure to perform when properly used in accordance with instructions for use provided in the labeling, can be reasonably expected to result in significant injury to the user.
2. A critical component is any component of a life support device or system whose failure to perform can be reasonably expected to cause the failure of the life support device or system, or to affect its safety or effectiveness.

## PRODUCT STATUS DEFINITIONS

### Definition of Terms

Datasheet Identification	Product Status	Definition
Advance Information	Formative or In Design	This datasheet contains the design specifications for product development. Specifications may change in any manner without notice.
Preliminary	First Production	This datasheet contains preliminary data, and supplementary data will be published at a later date. Fairchild Semiconductor reserves the right to make changes at any time without notice in order to improve design.
No Identification Needed	Full Production	This datasheet contains final specifications. Fairchild Semiconductor reserves the right to make changes at any time without notice in order to improve design.
Obsolete	Not In Production	This datasheet contains specifications on a product that has been discontinued by Fairchild semiconductor. The datasheet is printed for reference information only.



LittleDiode supplies new, hard to find or obsolete electronic components and semiconductors all over the world.

With over two million different components listed you are sure to find the part you need.

Feel free to visit us today at our online store:

[LittleDiode.com](http://LittleDiode.com)

Looking forward to providing you with the best possible service.