

HGTP14N40F3VL / HGT1S14N40F3VLS

330mJ, 400V, N-Channel Ignition IGBT

General Description

This N-Channel IGBT is a MOS gated, logic level device which is intended to be used as an ignition coil driver in automotive ignition circuits. Unique features include an active voltage clamp between the drain and the gate and ESD protection for the logic level gate. Some specifications are unique to this automotive application and are intended to assure device survival in this harsh environment.

Formerly Developmental Type 49023

Applications

- Automotive Ignition Coil Driver Circuits
- Coil-On Plug Applications

Features

- Logic Level Gate Drive
- Internal Voltage Clamp
- ESD Gate Protection
- Max $T_J = 175^\circ\text{C}$
- SCIS Energy = 330mJ at $T_J = 25^\circ\text{C}$

Package

JEDEC TO-263AB
D²-Pak

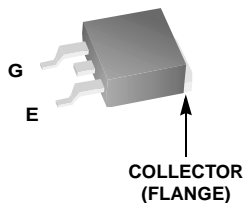

JEDEC TO-220AB

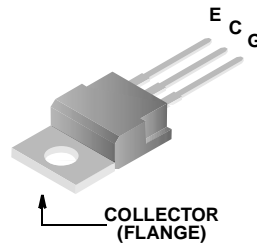

Symbol

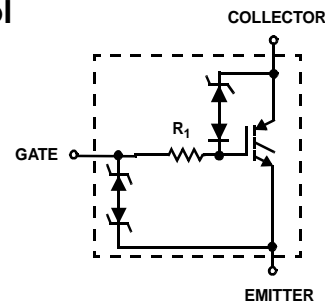

Device Maximum Ratings $T_A = 25^\circ\text{C}$ unless otherwise noted

Symbol	Parameter	Ratings	Units
BV_{CES}	Collector to Emitter Breakdown Voltage ($I_C = 1 \text{ mA}$)	420	V
BV_{CGR}	Collector to Gate Breakdown Voltage ($R_{GE} = 10\text{K}\Omega$)	420	V
E_{SCIS25}	Drain to Source Avalanche Energy at $L = 2.3\text{mH}$, $T_C = 25^\circ\text{C}$	330	mJ
I_{C25}	Collector Current Continuous, at $T_C = 25^\circ\text{C}$, $V_{GE} = 4.5\text{V}$	38	A
I_{C90}	Collector Current Continuous, at $T_C = 90^\circ\text{C}$, $V_{GE} = 4.5\text{V}$	35	A
V_{GES}	Gate to Emitter Voltage Continuous	± 10	V
V_{GEM}	Gate to Emitter Voltage Pulsed	± 12	V
I_{CO}	$L = 2.3\text{mH}$, $T_C = 25^\circ\text{C}$	17	A
I_{CO}	$L = 2.3\text{mH}$, $T_C = 150^\circ\text{C}$	12	A
P_D	Power Dissipation Total $T_C = 25^\circ\text{C}$	262	W
	Power Dissipation Derating $T_C > 25^\circ\text{C}$	1.75	W/ $^\circ\text{C}$
T_J, T_{STG}	Operating and Storage Junction Temperature Range	-40 to 175	$^\circ\text{C}$
T_L	Max Lead Temp for Soldering (Leads at 1.6mm from Case for 10s)	300	$^\circ\text{C}$
T_{pkg}	Max Lead Temp for Soldering (Package Body for 10s)	260	$^\circ\text{C}$
ESD	Electrostatic Discharge Voltage at 100pF, 1500Ω	6	KV

Package Marking and Ordering Information

Device Marking	Device	Package	Reel Size	Tape Width	Quantity
14N40FVL	HGT1S14N40F3VLT	TO-263AB	24mm	24mm	800 units
14N40FVL	HGT1S14N40F3VLS	TO-263AB	Tube	N/A	50 units
14N40FVL	HGTP14N40F3VL	TO-220AB	Tube	N/A	50 units

Electrical Characteristics $T_A = 25^\circ\text{C}$ unless otherwise noted

Symbol	Parameter	Test Conditions	Min	Typ	Max	Units
--------	-----------	-----------------	-----	-----	-----	-------

Off State Characteristics

BV_{CES}	Collector to Emitter Breakdown Voltage	$I_C = 10\text{mA}$, $V_{GE} = 0$	$T_C = 150^\circ\text{C}$	345	370	415	V
			$T_C = 25^\circ\text{C}$	350	375	420	V
			$T_C = -40^\circ\text{C}$	355	380	425	V
$BV_{CE(CL)}$	Collector to Emitter Clamp Breakdown Voltage	$I_C = 10\text{A}$, $R_G = 0$	$T_C = 150^\circ\text{C}$	350	385	430	V
BV_{ECS}	Emitter to Collector Breakdown Voltage	$I_C = 1\text{mA}$	$T_C = 25^\circ\text{C}$	24	-	-	V
BV_{GES}	Gate to Emitter Breakdown Voltage	$I_{GES} = \pm 1\text{mA}$		± 12	-	-	V
I_{CES}	Collector to Emitter Leakage Current	$V_{CE} = 250\text{V}$,	$T_C = 25^\circ\text{C}$	-	-	50	μA
			$T_C = 150^\circ\text{C}$	-	-	250	μA
I_{GES}	Gate to Emitter Leakage Current	$V_{GE} = \pm 10\text{V}$	$T_C = 25^\circ\text{C}$	-	-	± 10	μA
R_1	Series Gate Resistance			-	1000	-	Ω

On State Characteristics

$V_{CE(SAT)}$	Collector to Emitter Saturation Voltage	$I_C = 10\text{A}$, $V_{GE} = 4.5\text{V}$	$T_C = 25^\circ\text{C}$	-	1.3	2.0	V
			$T_C = 150^\circ\text{C}$	-	1.4	2.3	V
$V_{GE(TH)}$	Gate to Emitter Threshold Voltage	$I_C = 1\text{mA}$, $V_{CE} = V_{GE}$	$T_C = 25^\circ\text{C}$	1.0	-	2.0	V
			$T_C = 150^\circ\text{C}$	0.5	-	-	V

Switching Characteristics

$t_{d(OFF)} + t_{f(OFF)}$	Current Turn-Off Time-Inductive Load	$I_C = 6.5\text{A}$, $R_G = 25\Omega$, $L = 550\mu\text{H}$, $V_{CL} = 320\text{V}$, $V_{GE} = 5\text{V}$, $T_C = 25^\circ\text{C}$		-	12	16	μs
SCIS	Self Clamped Inductive Switching	$L = 2.3\text{mH}$, $V_{GE} = 5\text{V}$, See Fig. 1 & 2	$T_C = 25^\circ\text{C}$	17	-	-	A
			$T_C = 150^\circ\text{C}$	12	-	-	A

Thermal Characteristics

$R_{\theta JC}$	Thermal Resistance Junction to Case		-	-	0.57	$^\circ\text{C/W}$
-----------------	-------------------------------------	--	---	---	------	--------------------

Typical Performance Curves (Continued)

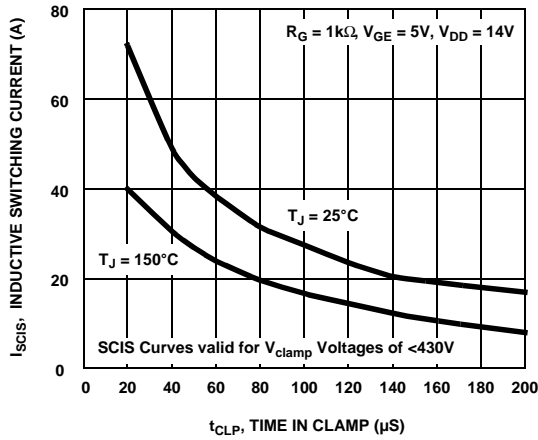

Figure 1. Self Clamped Inductive Switching Current vs Time

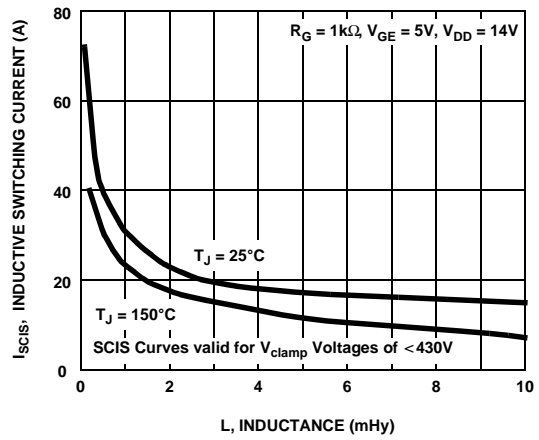

Figure 2. Self Clamped Inductive Switching Current vs Inductance

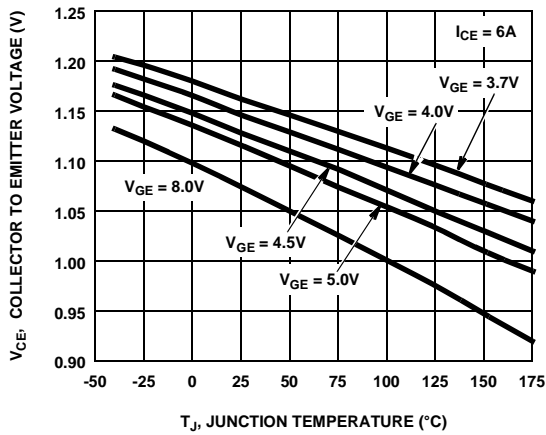

Figure 3. Collector to Emitter On-State Voltage vs Junction Temperature

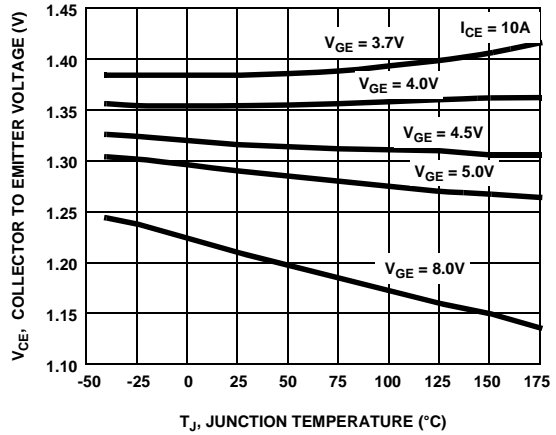

Figure 4. Collector to Emitter On-State Voltage vs Junction Temperature

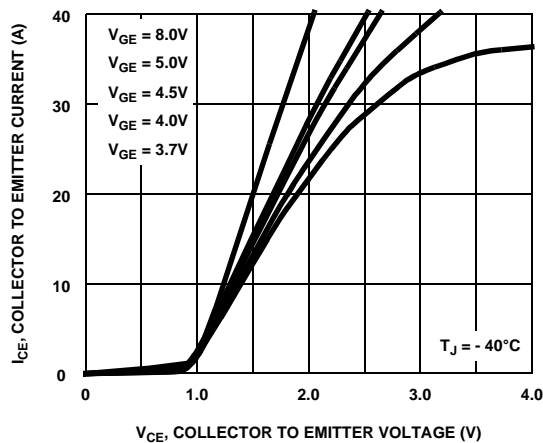

Figure 5. Collector to Emitter Current vs Collector to Emitter On-State Voltage

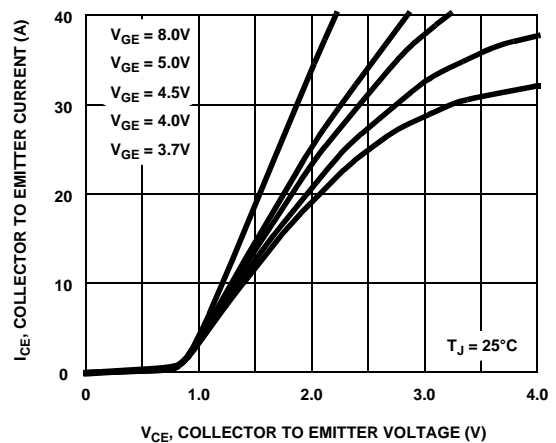

Figure 6. Collector to Emitter Current vs Collector to Emitter On-State Voltage

Typical Performance Curves (Continued)

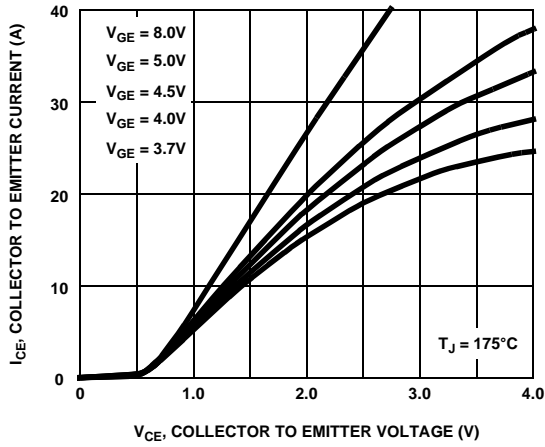

Figure 7. Collector to Emitter Current vs Collector to Emitter On-State Voltage

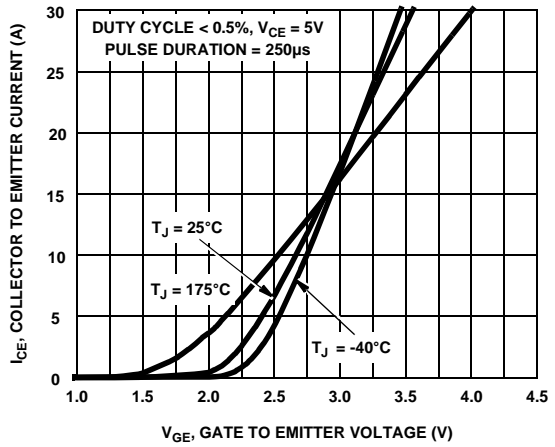

Figure 8. Transfer Characteristics

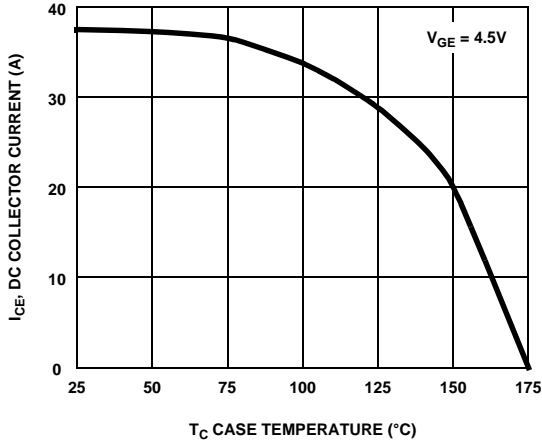

Figure 9. DC Collector Current vs Case Temperature

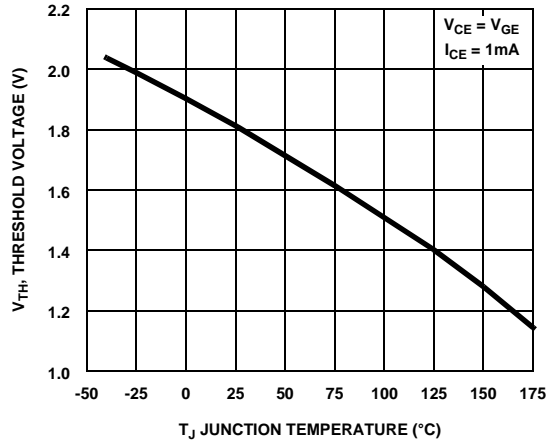

Figure 10. Threshold Voltage vs Junction Temperature

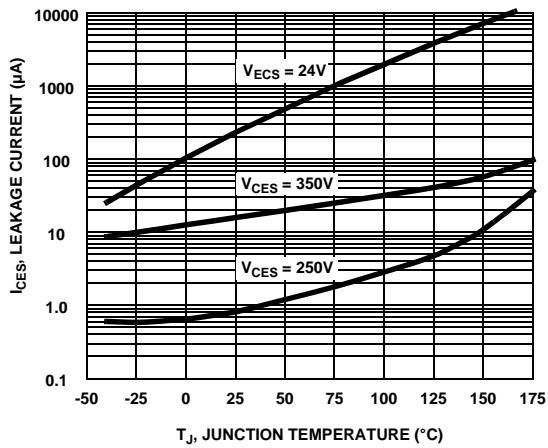

Figure 11. Leakage Current vs Junction Temperature

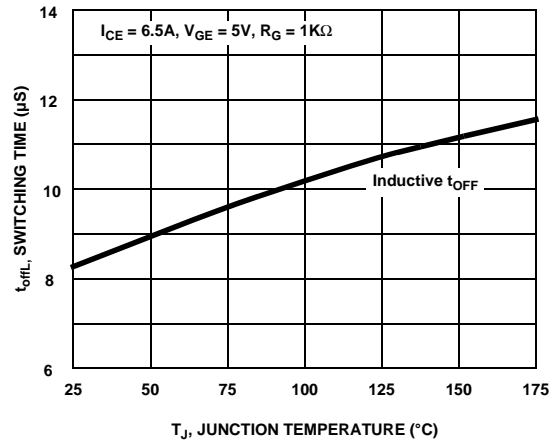

Figure 12. Switching Time vs Junction Temperature

Test Circuit and Waveforms

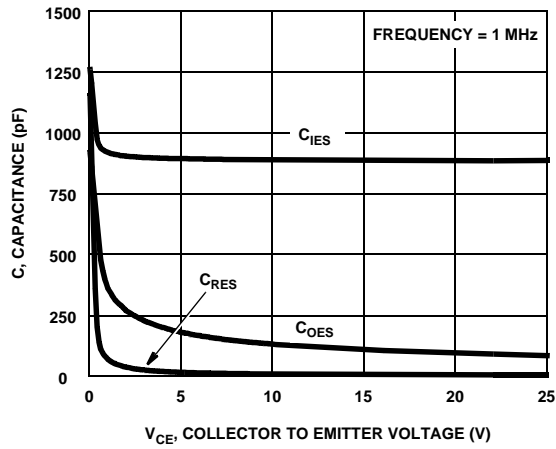

Figure 13. Capacitance vs Collector to Emitter Voltage

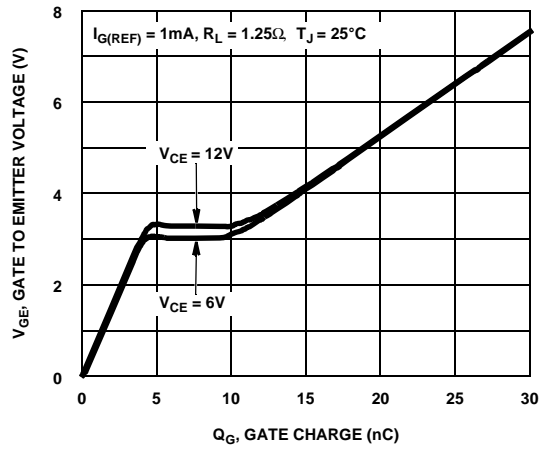

Figure 14. Gate Charge

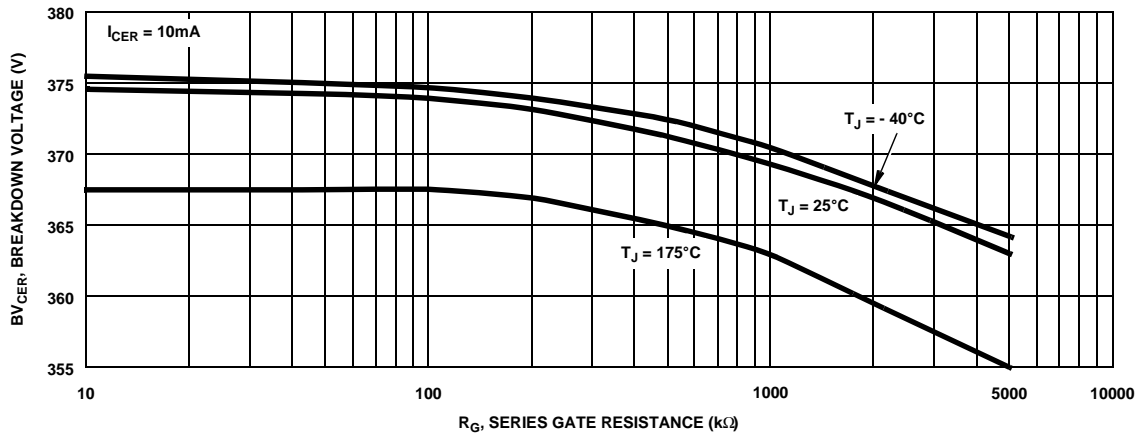

Figure 15. Breakdown Voltage vs Series Gate Resistance

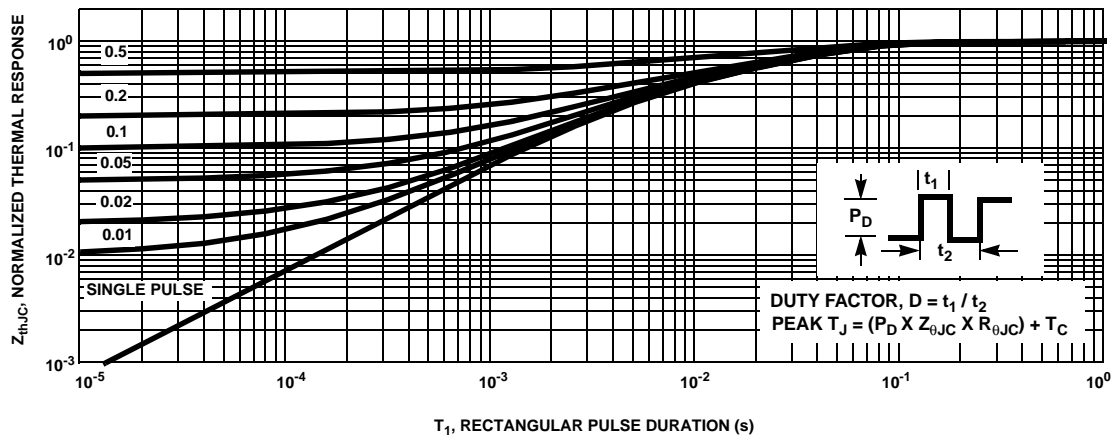

Figure 16. Normalized Transient Thermal Impedance

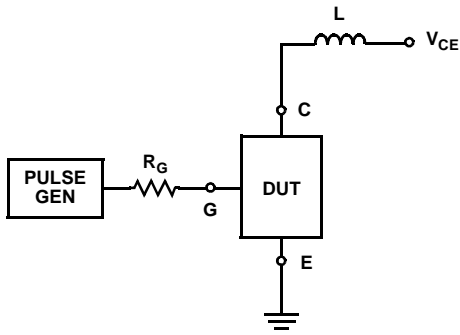

Figure 17. Inductive Switching Test Circuit

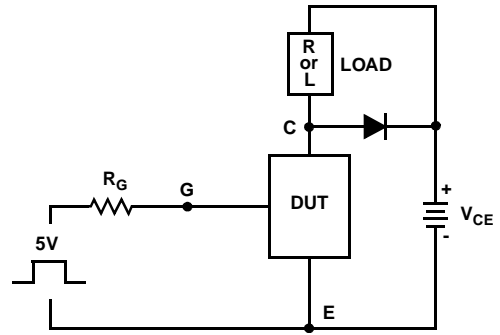

Figure 18. t_{ON} and t_{OFF} Switching Test Circuit

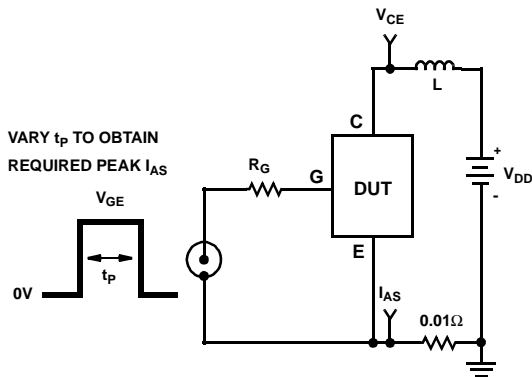

Figure 19. Unclamped Energy Test Circuit

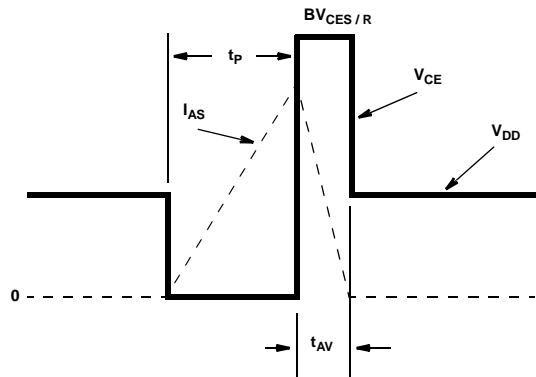

Figure 20. Unclamped Energy Waveforms

TRADEMARKS

The following are registered and unregistered trademarks Fairchild Semiconductor owns or is authorized to use and is not intended to be an exhaustive list of all such trademarks.

ACE _x TM	FAST [®]	OPTOLOGIC TM	SMART START TM	VCX TM
Bottomless TM	FAST _r TM	OPTOPLANAR TM	STAR*POWER TM	
CoolFET TM	FRFET TM	PACMAN TM	Stealth TM	
CROSSVOLT TM	GlobalOptoisolator TM	POPT TM	SuperSOT TM -3	
DenseTrench TM	GTO TM	Power247 TM	SuperSOT TM -6	
DOMET TM	HiSeC TM	PowerTrench [®]	SuperSOT TM -8	
EcoSPARK TM	ISOPLANAR TM	QFET TM	SyncFET TM	
E ² CMOS TM	LittleFET TM	QST TM	TinyLogic TM	
EnSigna TM	MicroFET TM	QT Optoelectronics TM	TruTranslation TM	
FACT TM	MicroPak TM	Quiet Series TM	UHC TM	
FACT Quiet Series TM	MICROWIRE TM	SILENT SWITCHER [®]	UltraFET [®]	

STAR*POWER is used under license

DISCLAIMER

FAIRCHILD SEMICONDUCTOR RESERVES THE RIGHT TO MAKE CHANGES WITHOUT FURTHER NOTICE TO ANY PRODUCTS HEREIN TO IMPROVE RELIABILITY, FUNCTION OR DESIGN. FAIRCHILD DOES NOT ASSUME ANY LIABILITY ARISING OUT OF THE APPLICATION OR USE OF ANY PRODUCT OR CIRCUIT DESCRIBED HEREIN; NEITHER DOES IT CONVEY ANY LICENSE UNDER ITS PATENT RIGHTS, NOR THE RIGHTS OF OTHERS.

LIFE SUPPORT POLICY

FAIRCHILD'S PRODUCTS ARE NOT AUTHORIZED FOR USE AS CRITICAL COMPONENTS IN LIFE SUPPORT DEVICES OR SYSTEMS WITHOUT THE EXPRESS WRITTEN APPROVAL OF FAIRCHILD SEMICONDUCTOR CORPORATION.

As used herein:

1. Life support devices or systems are devices or systems which, (a) are intended for surgical implant into the body, or (b) support or sustain life, or (c) whose failure to perform when properly used in accordance with instructions for use provided in the labeling, can be reasonably expected to result in significant injury to the user.
2. A critical component is any component of a life support device or system whose failure to perform can be reasonably expected to cause the failure of the life support device or system, or to affect its safety or effectiveness.

PRODUCT STATUS DEFINITIONS

Definition of Terms

Datasheet Identification	Product Status	Definition
Advance Information	Formative or In Design	This datasheet contains the design specifications for product development. Specifications may change in any manner without notice.
Preliminary	First Production	This datasheet contains preliminary data, and supplementary data will be published at a later date. Fairchild Semiconductor reserves the right to make changes at any time without notice in order to improve design.
No Identification Needed	Full Production	This datasheet contains final specifications. Fairchild Semiconductor reserves the right to make changes at any time without notice in order to improve design.
Obsolete	Not In Production	This datasheet contains specifications on a product that has been discontinued by Fairchild semiconductor. The datasheet is printed for reference information only.



LittleDiode supplies new, hard to find or obsolete electronic components and semiconductors all over the world.

With over two million different components listed you are sure to find the part you need.

Feel free to visit us today at our online store:

LittleDiode.com

Looking forward to providing you with the best possible service.