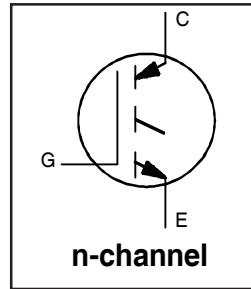


PDP Switch

**Features**

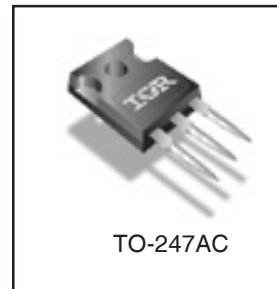
- Key parameters optimized for PDP sustain & Energy recovery applications
- 104A continuous collector current rating reduces component count
- High pulse current rating makes it ideal for capacitive load circuits
- Low temperature co-efficient of  $V_{CE(ON)}$  ensures reduced power dissipation at operating junction temperatures
- Reverse voltage avalanche rating improves the robustness in sustain driver application
- Short fall & rise times for fast switching



$V_{CES} = 250V$

$V_{CE(on) typ.} = 1.64V$

@ $V_{GE} = 15V, I_C = 30A$



**Description**

This IGBT is specifically designed for sustain & energy recovery application in plasma display panels. This IGBT features low  $V_{CE(ON)}$  and fast switching times to improve circuit efficiency and reliability. Low temperature co-efficient of  $V_{CE(ON)}$  makes this IGBT an ideal device for PDP sustain driver application.

**Absolute Maximum Ratings**

	Parameter	Max.	Units
$V_{CES}$	Collector-to-Emitter Voltage	250	V
$I_C @ T_C = 25^\circ C$	Continuous Collector Current	104*	A
$I_C @ T_C = 100^\circ C$	Continuous Collector Current	56	
$I_{CM}$	Pulse Collector Current ①	208	
$I_{LM}$	Clamped Inductive Load current ②	290	
$V_{GE}$	Gate-to-Emitter Voltage	$\pm 20$	V
$E_{ARV}$	Reverse Voltage Avalanche Energy ③	1240	mJ
$P_D @ T_C = 25^\circ C$	Maximum Power Dissipation	330	W
$P_D @ T_C = 100^\circ C$	Maximum Power Dissipation	130	
$T_J$	Operating Junction and Storage Temperature Range	-55 to +150	°C
$T_{STG}$			
	Solder Temperature Range, for 10 sec.	300 (0.063 in. (1.6mm) from case)	

**Thermal / Mechanical Characteristics**

	Parameter	Min.	Typ.	Max.	Units
$R_{\theta JC}$	Junction-to-Case- IGBT	—	—	0.38	°C/W
$R_{\theta CS}$	Case-to-Sink, flat, greased surface	—	0.24	—	
$R_{\theta JA}$	Junction-to-Ambient, typical socket mount	—	—	40	
Wt	Weight	—	6 (0.21)	—	g (oz.)

\*Package limited to 60A.

## Electrical Characteristics @ T<sub>J</sub> = 25°C (unless otherwise specified)

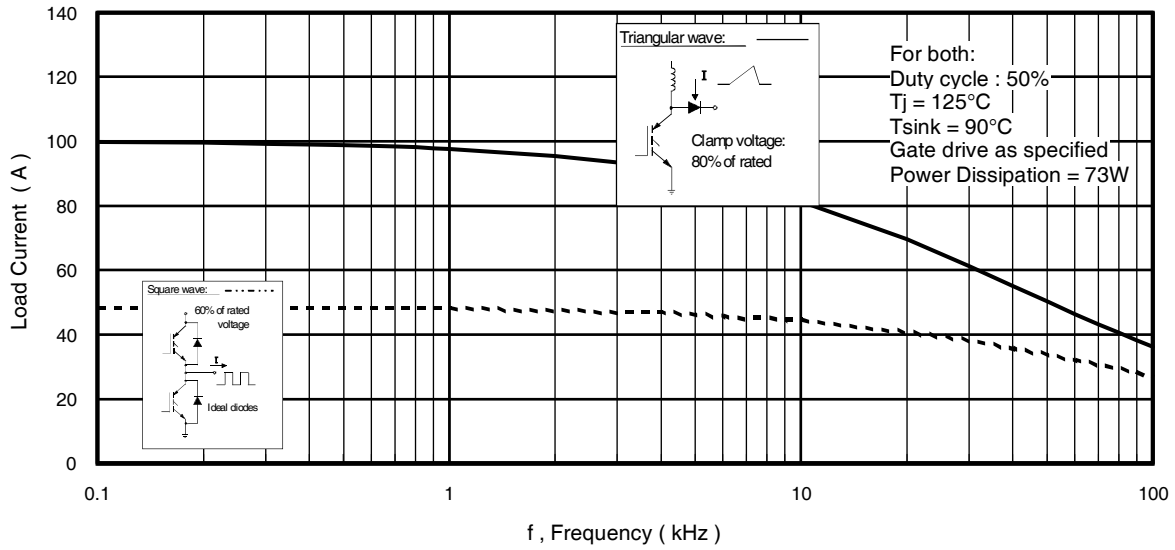
Parameter	Min.	Typ.	Max.	Units	Conditions	
V <sub>(BR)CES</sub>	250	—	—	V	V <sub>GE</sub> = 0V, I <sub>C</sub> = 250μA	
V <sub>(BR)ECS</sub>	18	—	—	V	V <sub>GE</sub> = 0V, I <sub>C</sub> = 1.0A	
ΔV <sub>(BR)CES</sub> /ΔT <sub>J</sub>	—	8.2	—	mV/°C	V <sub>GE</sub> = 0V, I <sub>C</sub> = 1mA	
V <sub>CE(on)</sub>	Collector-to-Emitter Saturation Voltage	—	1.64	1.90	V	I <sub>C</sub> = 30A I <sub>C</sub> = 56A I <sub>C</sub> = 104A, T <sub>J</sub> = 150°C V <sub>GE</sub> = 15V See Fig. 2, 5
		—	2.04	—		
		—	2.60	—		
V <sub>GE(th)</sub>	3.0	—	6.0		V <sub>CE</sub> = V <sub>GE</sub> , I <sub>C</sub> = 250μA	
ΔV <sub>GE(th)</sub> /ΔT <sub>J</sub>	—	-11	—	mV/°C	V <sub>CE</sub> = V <sub>GE</sub> , I <sub>C</sub> = 0.25mA	
g <sub>fe</sub>	34	51	—	S	V <sub>CE</sub> = 100V, I <sub>C</sub> = 56A	
I <sub>CES</sub>	Zero Gate Voltage Collector Current	—	—	250	μA	V <sub>GE</sub> = 0V, V <sub>CE</sub> = 250V V <sub>GE</sub> = 0V, V <sub>CE</sub> = 10V V <sub>GE</sub> = 0V, V <sub>CE</sub> = 250V, T <sub>J</sub> = 150°C
		—	—	2.0		
		—	—	5000		
I <sub>GES</sub>	Gate-to-Emitter Leakage Current	—	—	±100	nA	V <sub>GE</sub> = ±20V

## Switching Characteristics @ T<sub>J</sub> = 25°C (unless otherwise specified)

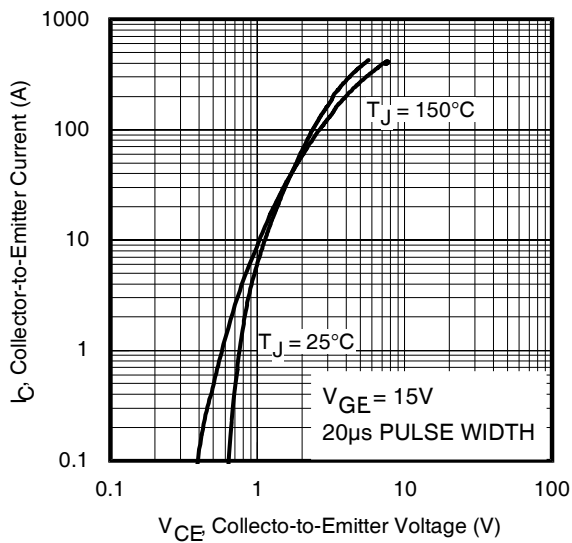
Parameter	Min.	Typ.	Max.	Units	Conditions
Q <sub>g</sub>	—	230	350	nC	I <sub>C</sub> = 56A V <sub>CC</sub> = 200V V <sub>GE</sub> = 15V See Fig. 8
Q <sub>ge</sub>	—	37	56		
Q <sub>gc</sub>	—	78	120		
t <sub>d(on)</sub>	—	37	—	ns	T <sub>J</sub> = 25°C I <sub>C</sub> = 30A, V <sub>CC</sub> = 180V V <sub>GE</sub> = 15V, R <sub>G</sub> = 5.0Ω Energy losses include "tail" See Fig. 9, 10, 14
t <sub>r</sub>	—	35	—		
t <sub>d(off)</sub>	—	120	180		
t <sub>f</sub>	—	59	89		
E <sub>on</sub>	—	45	—		
E <sub>off</sub>	—	125	—	μJ	
E <sub>TS</sub>	—	170	—		
t <sub>d(on)</sub>	—	35	—	ns	T <sub>J</sub> = 150°C I <sub>C</sub> = 30A, V <sub>CC</sub> = 180V V <sub>GE</sub> = 15V, R <sub>G</sub> = 5.0Ω Energy losses include "tail" See Fig. 11, 14
t <sub>r</sub>	—	35	—		
t <sub>d(off)</sub>	—	130	—		
t <sub>f</sub>	—	120	—		
E <sub>TS</sub>	—	280	—		
L <sub>E</sub>	—	13	—	nH	Measured 5mm from package
C <sub>ies</sub>	—	4650	—	pF	V <sub>GE</sub> = 0V V <sub>CC</sub> = 30V, f = 1.0MHz See Fig. 7
C <sub>oes</sub>	—	480	—		
C <sub>res</sub>	—	92	—		

### Notes:

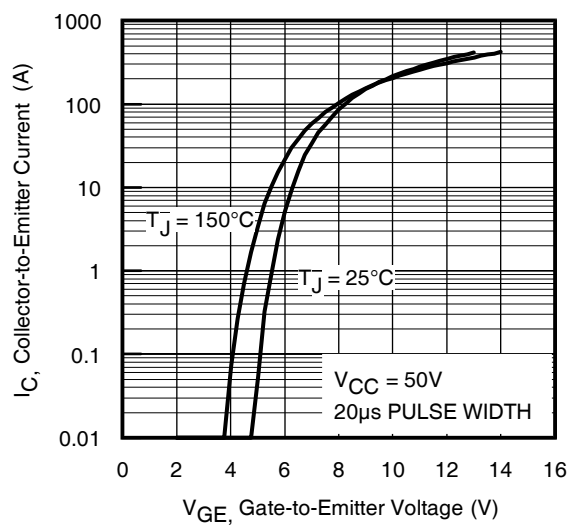
- ① Repetitive rating; V<sub>GE</sub> = 20V, pulse width limited by max. junction temperature. ( See fig. 13b )
- ② V<sub>CC</sub> = 80%(V<sub>CES</sub>), V<sub>GE</sub> = 20V, L = 10μH, R<sub>G</sub> = 5.0Ω, (See fig. 13a).
- ③ Repetitive rating; pulse width limited by maximum junction temperature.
- ④ Pulse width ≤ 2.5ms; duty factor ≤ 0.1%.
- ⑤ Pulse width 5.0μs, single shot.



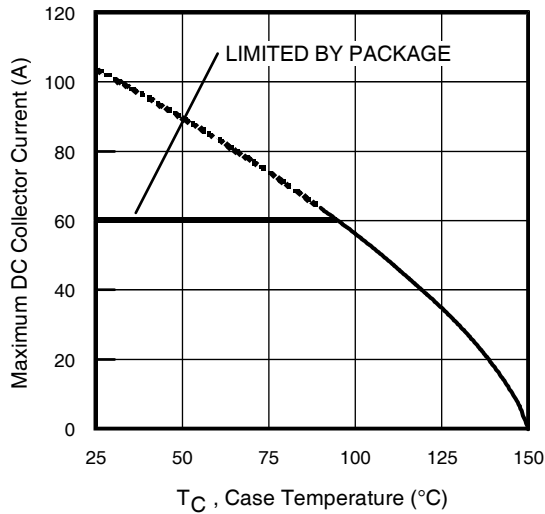
**Fig. 1 - Typical Load Current vs. Frequency**  
(Load Current =  $I_{RMS}$  of fundamental)



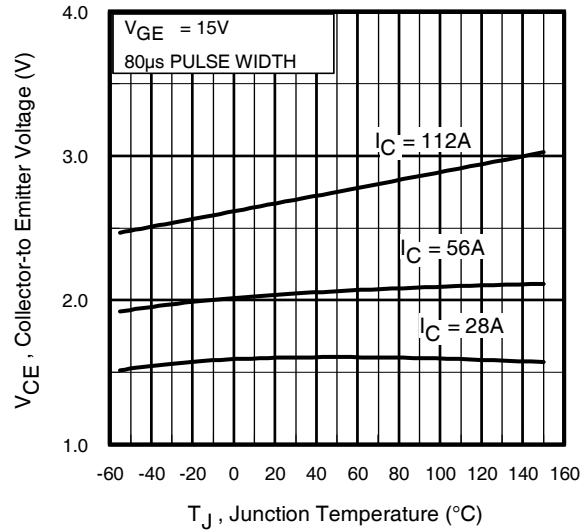
**Fig. 2 - Typical Output Characteristics**



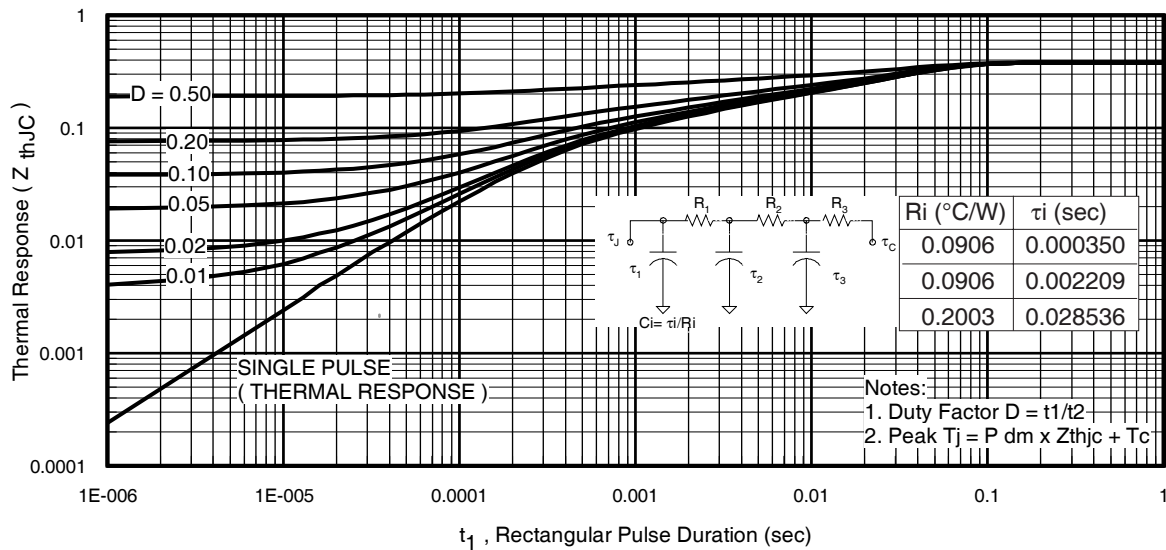
**Fig. 3 - Typical Transfer Characteristics**



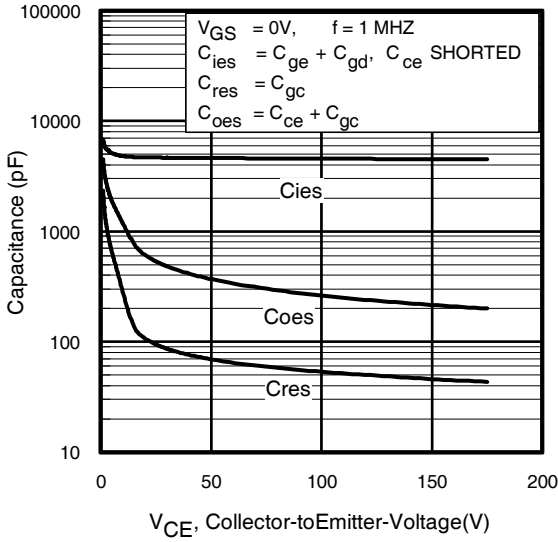
**Fig. 4 - Maximum Collector Current vs. Case Temperature**



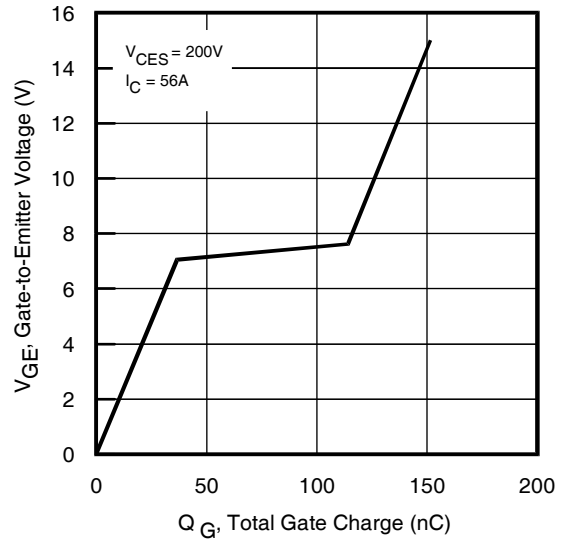
**Fig. 5 - Typical Collector-to-Emitter Voltage vs. Junction Temperature**



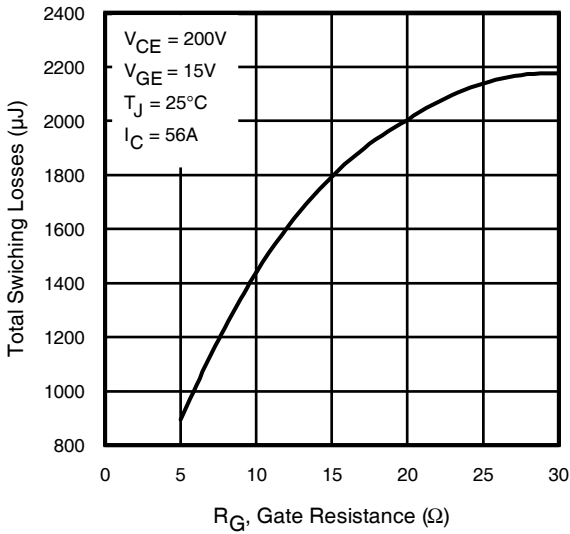
**Fig. 6 - Maximum Effective Transient Thermal Impedance, Junction-to-Case**



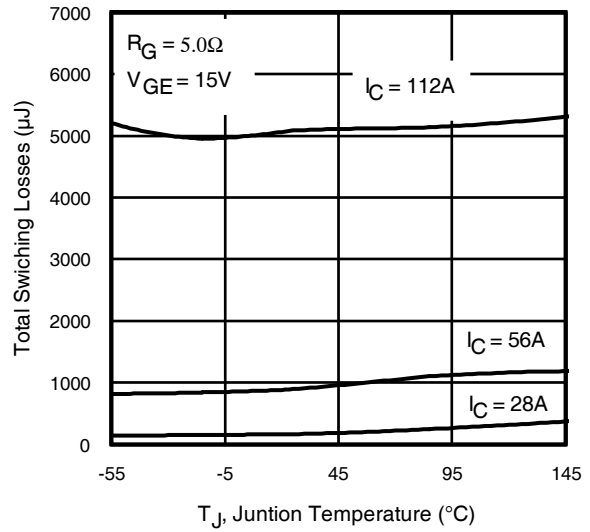
**Fig. 7** - Typical Capacitance vs. Collector-to-Emitter Voltage



**Fig. 8** - Typical Gate Charge vs. Gate-to-Emitter Voltage

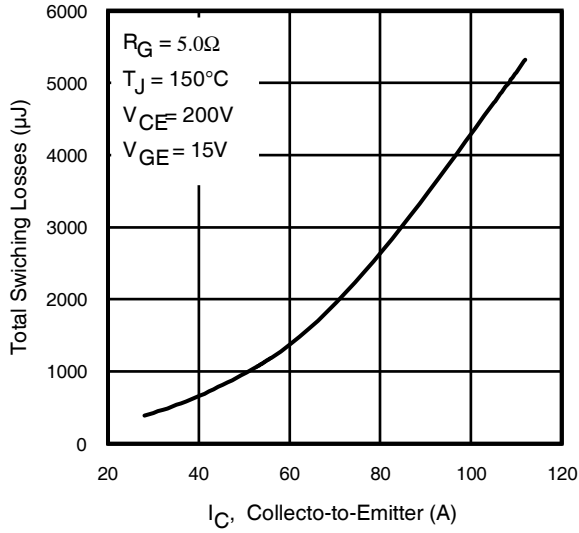


**Fig. 9** - Typical Switching Losses vs. Gate Resistance

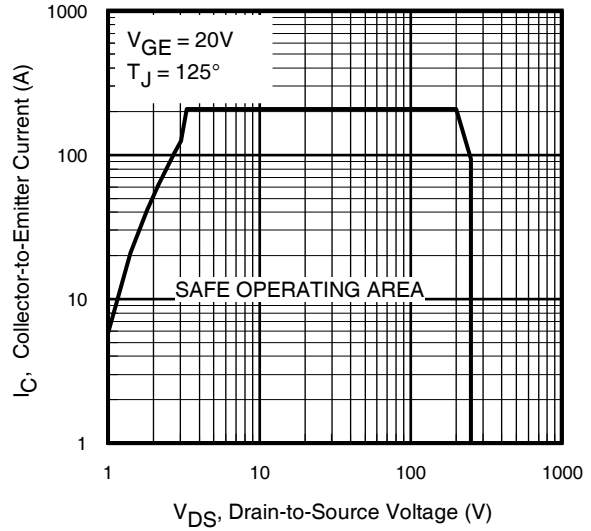


**Fig. 10** - Typical Switching Losses vs. Junction Temperature

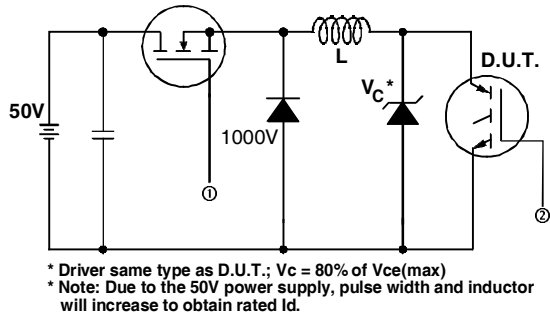
# IRGP4050



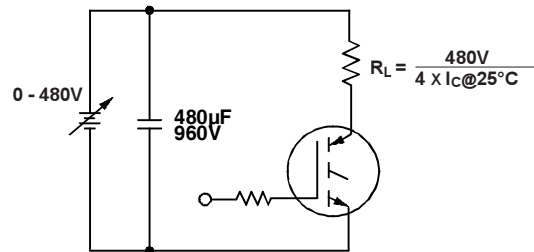
**Fig. 11** - Typical Switching Losses vs. Collector-to-Emitter Current



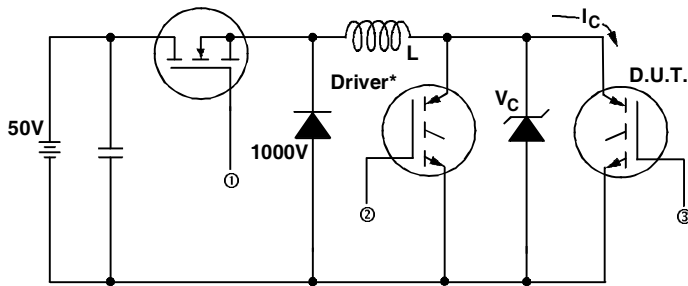
**Fig. 12** - Turn-Off SOA



**Fig. 13a** - Clamped Inductive Load Test Circuit

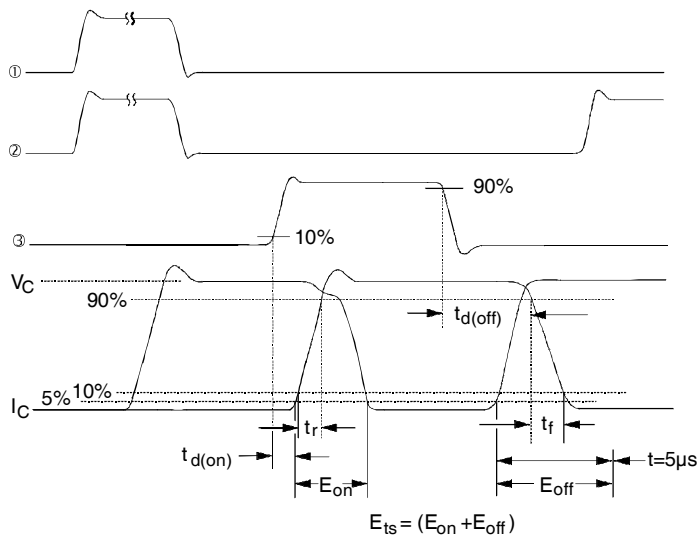


**Fig. 13b** - Pulsed Collector Current Test Circuit



**Fig. 14a** - Switching Loss Test Circuit

\* Driver same type as D.U.T., Vc = 480V



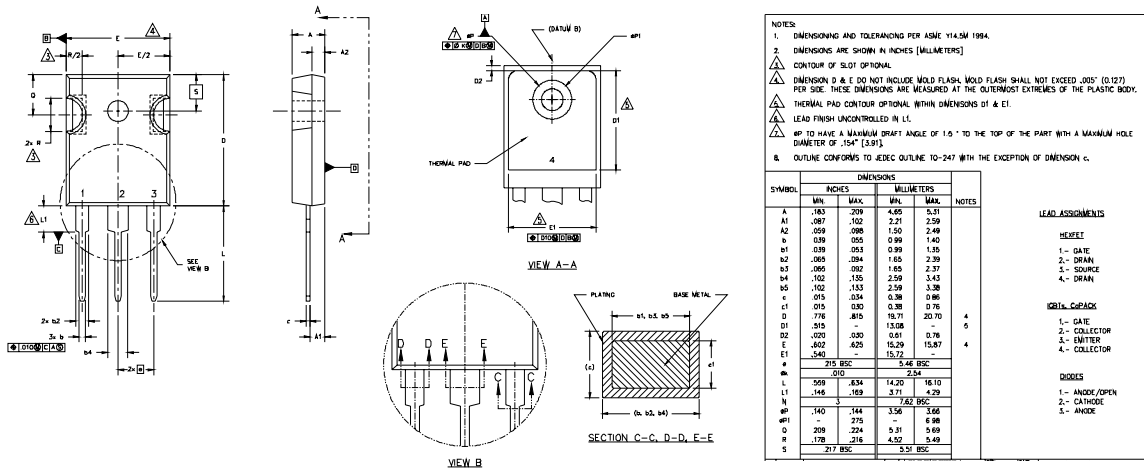
**Fig. 14b** - Switching Loss Waveforms

# IRGP4050

## TO-247AC Package Outline

Dimensions are shown in millimeters (inches)

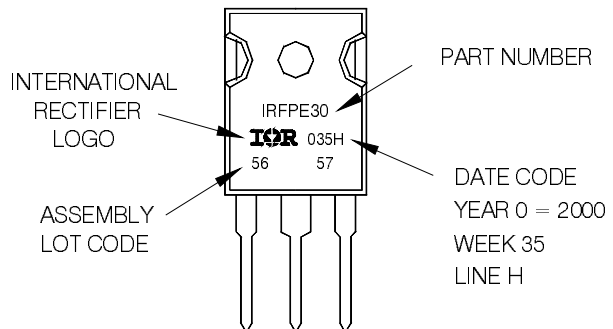
International  
**IR** Rectifier



## TO-247AC Part Marking Information

EXAMPLE: THIS IS AN IRFPE30  
WITH ASSEMBLY  
LOT CODE 5657  
ASSEMBLED ON WW 35, 2000  
IN THE ASSEMBLY LINE "H"

**Note:** "P" in assembly line position indicates "Lead-Free"



**TO-247AC package is not recommended for Surface Mount Application.**

Data and specifications subject to change without notice.  
This product has been designed and qualified for the Industrial market.  
Qualification Standards can be found on IR's Web site.

International  
**IR** Rectifier

IR WORLD HEADQUARTERS: 233 Kansas St., El Segundo, California 90245, USA Tel: (310) 252-7105  
TAC Fax: (310) 252-7903

Visit us at [www.irf.com](http://www.irf.com) for sales contact information.06/04



LittleDiode supplies new, hard to find or obsolete electronic components and semiconductors all over the world.

With over two million different components listed you are sure to find the part you need.

Feel free to visit us today at our online store:

**[LittleDiode.com](http://LittleDiode.com)**

Looking forward to providing you with the best possible service.