

REPETITIVE AVALANCHE AND dv/dt RATED HEXFET® TRANSISTOR

IRHM9230

P-CHANNEL
RAD HARD

-200 Volt, 0.8 Ω , RAD HARD HEXFET

International Rectifier's P-Channel RAD HARD technology HEXFETs demonstrate excellent threshold voltage stability and breakdown voltage stability at total radiation doses as high as 10^5 Rads (Si). Under **identical** pre- and post-radiation test conditions, International Rectifier's P-Channel RAD HARD HEXFETs retain **identical** electrical specifications up to 1×10^5 Rads (Si) total dose. No compensation in gate drive circuitry is required. These devices are also capable of surviving transient ionization pulses as high as 1×10^{12} Rads (Si)/Sec, and return to normal operation within a few microseconds. Single Event Effect (SEE) testing of International Rectifier P-Channel RAD HARD HEXFETs has demonstrated virtual immunity to SEE failure. Since the P-Channel RAD HARD process utilizes International Rectifier's patented HEXFET technology, the user can expect the highest quality and reliability in the industry.

P-Channel RAD HARD HEXFET transistors also feature all of the well-established advantages of MOSFETs, such as voltage control, very fast switching, ease of paralleling and temperature stability of the electrical parameters.

They are well-suited for applications such as switching power supplies, motor controls, inverters, choppers, audio amplifiers and high-energy pulse circuits in space and weapons environments.

Product Summary

Part Number	BV_{DSS}	$R_{DS(on)}$	I_D
IRHM9230	-200V	0.8 Ω	-6.5A

Features:

- Radiation Hardened up to 1×10^5 Rads (Si)
- Single Event Burnout (SEB) Hardened
- Single Event Gate Rupture (SEGR) Hardened
- Gamma Dot (Flash X-Ray) Hardened
- Neutron Tolerant
- Identical Pre- and Post-Electrical Test Conditions
- Repetitive Avalanche Rating
- Dynamic dv/dt Rating
- Simple Drive Requirements
- Ease of Paralleling
- Hermetically Sealed
- Ceramic Eyelets
- Electrically Isolated

Absolute Maximum Ratings

Pre-Radiation

	Parameter	IRHM9230	Units
I_D @ $V_{GS} = -12V, T_C = 25^\circ C$	Continuous Drain Current	-6.5	A
I_D @ $V_{GS} = -12V, T_C = 100^\circ C$	Continuous Drain Current	-4.1	
I_{DM}	Pulsed Drain Current ①	-26	
P_D @ $T_C = 25^\circ C$	Max. Power Dissipation	75	W
	Linear Derating Factor	0.2	W/K ⑤
V_{GS}	Gate-to-Source Voltage	± 20	V
EAS	Single Pulse Avalanche Energy②	330	mJ
I_{AR}	Avalanche Current ①	-6.5	A
EAR	Repetitive Avalanche Energy②	7.5	mJ
dv/dt	Peak Diode Recovery dv/dt ③	-5.0	V/ns
T_J	Operating Junction	-55 to 150	$^\circ C$
T_{STG}	Storage Temperature Range		
	Lead Temperature	300 (0.063 in. (1.6mm) from case for 10s)	
	Weight	9.3 (typical)	

Notes: See page 4

Electrical Characteristics @ T_j = 25°C (Unless Otherwise Specified)

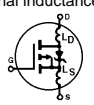
	Parameter	Min.	Typ.	Max.	Units	Test Conditions
BV _{DSS}	Drain-to-Source Breakdown Voltage	-200	—	—	V	V _{GS} = 0V, I _D = -1.0 mA
ΔBV _{DSS} /ΔT _J	Temperature Coefficient of Breakdown Voltage	—	-0.10	—	V/°C	Reference to 25°C, I _D = -1.0 mA
R _{DS(on)}	Static Drain-to-Source On-State Resistance	—	—	0.8	Ω	V _{GS} = -12V, I _D = -4.1A
		—	—	0.92		V _{GS} = -12V, I _D = -6.5A ④
V _{GS(th)}	Gate Threshold Voltage	-2.0	—	-4.0	V	V _{DS} = V _{GS} , I _D = -1.0 mA
g _{fs}	Forward Transconductance	2.2	—	—	S (Ω)	V _{DS} > -15V, I _{DS} = -6.5A④
I _{DSS}	Zero Gate Voltage Drain Current	—	—	-25	μA	V _{DS} = 0.8 x Max. Rating, V _{GS} = 0V
		—	—	-250		V _{DS} = 0.8 x Max. Rating V _{GS} = 0V, T _J = 125°C
I _{GSS}	Gate-to-Source Leakage Forward	—	—	-100	nA	V _{GS} = -20V
I _{GSS}	Gate-to-Source Leakage Reverse	—	—	100	nA	V _{GS} = 20V
Q _g	Total Gate Charge	—	—	35	nC	V _{GS} = -12V, I _D = -6.5A V _{DS} = Max. Rating x 0.5
Q _{gs}	Gate-to-Source Charge	—	—	10		
Q _{gd}	Gate-to-Drain (“Miller”) Charge	—	—	25		
t _{d(on)}	Turn-On Delay Time	—	—	50	ns	V _{DD} = -100V, I _D = -6.5A, R _G = 2.35Ω
t _r	Rise Time	—	—	90		
t _{d(off)}	Turn-Off Delay Time	—	—	90		
t _f	Fall Time	—	—	90		
L _D	Internal Drain Inductance	—	5.0	—	nH	Measured from the drain lead, 6mm (0.25 in.) from package to center of die. Modified MOSFET symbol showing the internal inductances. 
L _S	Internal Source Inductance	—	15	—		
C _{iss}	Input Capacitance	—	1100	—	pF	V _{GS} = 0V, V _{DS} = -25V f = 1.0 MHz
C _{oss}	Output Capacitance	—	310	—		
C _{rss}	Reverse Transfer Capacitance	—	55	—		

Source-Drain Diode Ratings and Characteristics

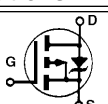
	Parameter	Min.	Typ.	Max.	Units	Test Conditions
I _S	Continuous Source Current (Body Diode)	—	—	-6.5	A	Modified MOSFET symbol showing the integral Reverse p-n junction rectifier. 
I _{SM}	Pulse Source Current (Body Diode) ①	—	—	-26		
V _{SD}	Diode Forward Voltage	—	—	-5.0	V	T _J = 25°C, I _S = -6.5A, V _{GS} = 0V ④
t _{rr}	Reverse Recovery Time	—	—	400	ns	T _J = 25°C, I _F = -6.5A, di/dt ≤ -100 A/μs V _{DD} ≤ -50V ④
Q _{RR}	Reverse Recovery Charge	—	—	3.0	μC	
t _{on}	Forward Turn-On Time	Intrinsic turn-on time is negligible. Turn-on speed is substantially controlled by L _S + L _D .				

Thermal Resistance

	Parameter	Min.	Typ.	Max.	Units	Test Conditions
R _{thJC}	Junction-to-Case	—	—	1.67	K/W ⑤	
R _{thJA}	Junction-to-Ambient	—	30	—		

Radiation Performance of P-Channel Rad Hard HEXFETs

International Rectifier Radiation Hardened HEXFETs are tested to verify their hardness capability. The hardness assurance program at International Rectifier uses two radiation environments.

Every manufacturing lot is tested in a low dose rate (total dose) environment per MIL-STD-750, test method 1019. International Rectifier has imposed a standard gate voltage of -12 volts per note 6 and a V_{DSS} bias condition equal to 80% of the device rated voltage per note 7. Pre- and post-radiation limits of the devices irradiated to 1×10^5 Rads (Si) are identical and are presented in Table 1. The values in Table 1 will be met for either of the two low dose rate test circuits that are used.

Both pre- and post-radiation performance are tested and specified using the same drive circuitry and test conditions in order to provide a direct comparison. It should be noted that at a radiation level of 1×10^5 Rads (Si), no change in limits are specified in DC parameters.

High dose rate testing may be done on a special request basis, using a dose rate up to 1×10^{12} Rads (Si)/Sec.

International Rectifier radiation hardened P-Channel HEXFETs are considered to be neutron-tolerant, as stated in MIL-PRF-19500 Group D. International Rectifier P-Channel radiation hardened HEXFETs have been characterized in heavy ion Single Event Effects environment and the results are shown in Table 3.

Table 1. Low Dose Rate ⑥ ⑦

Parameter		IRHM9230		Units	Test Conditions ⑩
		100K Rads (Si) min.	max.		
BV_{DSS}	Drain-to-Source Breakdown Voltage	-200	—	V	$V_{GS} = 0V, I_D = -1.0 \text{ mA}$
$V_{GS(th)}$	Gate Threshold Voltage ④	-2.0	-4.0	V	$V_{GS} = V_{DS}, I_D = -1.0 \text{ mA}$
I_{GSS}	Gate-to-Source Leakage Forward	—	-100	nA	$V_{GS} = -20V$
I_{GSS}	Gate-to-Source Leakage Reverse	—	100	nA	$V_{GS} = 20V$
I_{DSS}	Zero Gate Voltage Drain Current	—	-25	μA	$V_{DS} = 0.8 \times \text{Max Rating}, V_{GS} = 0V$
$R_{DS(on)1}$	Static Drain-to-Source ④ On-State Resistance One	—	0.8	Ω	$V_{GS} = -12V, I_D = -4.1A$
V_{SD}	Diode Forward Voltage ④	—	-5.0	V	$T_C = 25^\circ C, I_S = -6.5A, V_{GS} = 0V$

Table 2. High Dose Rate ⑧

Parameter	10 ¹¹ Rads (Si)/sec			10 ¹² Rads (Si)/sec			Units	Test Conditions
	Min.	Typ.	Max.	Min.	Typ.	Max.		
V_{DSS}	—	—	-160	—	—	-160	V	Applied drain-to-source voltage during gamma-dot
I_{PP}	—	-100	—	—	-100	—	A	Peak radiation induced photo-current
di/dt	—	-800	—	—	-160	—	A/ μ sec	Rate of rise of photo-current
L_1	1	—	—	20	—	—	μH	Circuit inductance required to limit di/dt

Table 3. Single Event Effects ⑨

Parameter	Typ.	Units	Ion	LET (Si) (MeV/mg/cm ²)	Fluence (ions/cm ²)	Range (μm)	V_{DS} Bias (V)	V_{GS} Bias (V)
BV_{DSS}	-200	V	Ni	28	1×10^6	~41	-200	5

- ① Repetitive Rating; Pulse width limited by maximum junction temperature. Refer to current HEXFET reliability report.
- ② @ $V_{DD} = -50V$, Starting $T_J = 25^\circ C$, $E_{AS} = [0.5 * L * (I_L^2) * [BV_{DSS}/(BV_{DSS}-V_{DD})]]$
Peak $I_L = -6.5A$, $V_{GS} = -12V$, $25 \leq R_G \leq 200 \Omega$
- ③ $I_{SD} \leq -6.5A$, $di/dt \leq -140 A/\mu s$, $V_{DD} \leq BV_{DSS}$, $T_J \leq 150^\circ C$
Suggested $R_G = 2.35\Omega$
- ④ Pulse width $\leq 300 \mu s$; Duty Cycle $\leq 2\%$
- ⑤ $K/W = ^\circ C/W$
 $W/K = W/^\circ C$
- ⑥ **Total Dose Irradiation with V_{GS} Bias.**
-12 volt V_{GS} applied and $V_{DS} = 0$ during irradiation per MIL-STD-750, method 1019.
- ⑦ **Total Dose Irradiation with V_{DS} Bias.**
 $V_{DS} = 0.8$ rated BV_{DSS} (pre-radiation) applied and $V_{GS} = 0$ during irradiation per MIL-STD-750, method 1019.
- ⑧ This test is performed using a flash x-ray source operated in the e-beam mode (energy ~2.5 MeV), 30 nsec pulse.
- ⑨ Process characterized by independent laboratory.
- ⑩ All Pre-Radiation and Post-Radiation test conditions are **identical** to facilitate direct comparison for circuit applications.

Case Outline and Dimensions

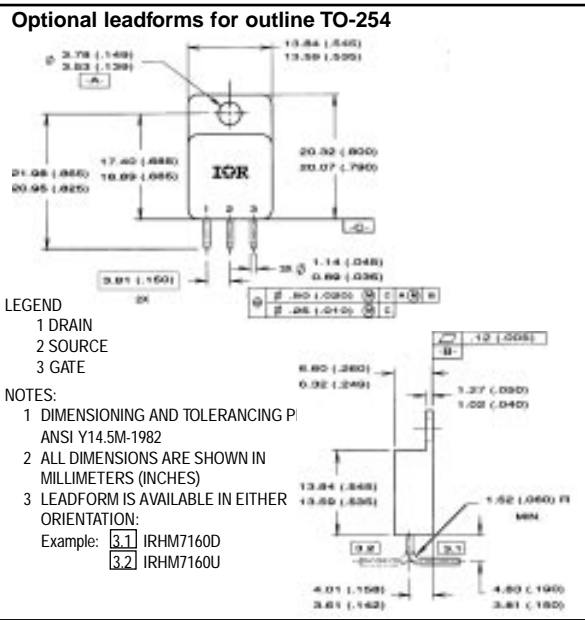
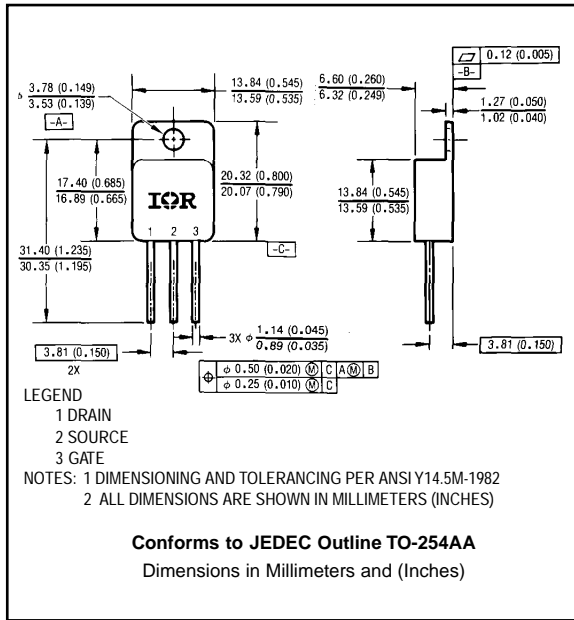

CAUTION

BERYLLIA WARNING PER MIL-PRF-19500

Packages containing beryllia shall not be ground, sandblasted, machined, or have other operations performed on them which will produce beryllia or beryllium dust. Furthermore, beryllium oxide packages shall not be placed in acids that will produce fumes containing beryllium.

WORLD HEADQUARTERS: 233 Kansas St., El Segundo, California 90245, Tel: (310) 322 3331
EUROPEAN HEADQUARTERS: Hurst Green, Oxted, Surrey RH8 9BB, UK Tel: ++ 44 1883 732020
IR CANADA: 7321 Victoria Park Ave., Suite 201, Markham, Ontario L3R 2Z8, Tel: (905) 475 1897
IR GERMANY: Saalburgstrasse 157, 61350 Bad Homburg Tel: ++ 49 6172 96590
IR ITALY: Via Liguria 49, 10071 Borgaro, Torino Tel: ++ 39 11 451 0111
IR FAR EAST: 171 (K&H Bldg.),30-4 Nishi-ikebukuro 3-Chome, Toshima-ku, Tokyo Japan Tel: 81 3 3983 0086
IR SOUTHEAST ASIA: 315 Outram Road, #10-02 Tan Boon Liat Building, Singapore 0316 Tel: 65 221 8371





LittleDiode supplies new, hard to find or obsolete electronic components and semiconductors all over the world.

With over two million different components listed you are sure to find the part you need.

Feel free to visit us today at our online store:

LittleDiode.com

Looking forward to providing you with the best possible service.