

REPETITIVE AVALANCHE AND dv/dt RATED HEXFET® TRANSISTOR

IRHM2C50SE IRHM7C50SE

N-CHANNEL SINGLE EVENT EFFECT (SEE) RAD HARD

600Volt, 0.6Ω, (SEE) RAD HARD HEXFET

International Rectifier's (SEE) RAD HARD technology HEXFETs demonstrate immunity to SEE failure. Additionally, under **identical** pre- and post-irradiation test conditions, International Rectifier's RAD HARD HEXFETs retain **identical** electrical specifications up to 1×10^5 Rads (Si) total dose. No compensation in gate drive circuitry is required. These devices are also capable of surviving transient ionization pulses as high as 1×10^{12} Rads (Si)/Sec, and return to normal operation within a few microseconds. Since the SEE process utilizes International Rectifier's patented HEXFET technology, the user can expect the highest quality and reliability in the industry.

RAD HARD HEXFET transistors also feature all of the well-established advantages of MOSFETs, such as voltage control, very fast switching, ease of paralleling and temperature stability of the electrical parameters. They are well-suited for applications such as switching power supplies, motor controls, inverters, choppers, audio amplifiers and high-energy pulse circuits in space and weapons environments.

Absolute Maximum Ratings

	Parameter	IRHM2C50SE, IRHM7C50SE	Units
I_D @ $V_{GS} = 12V, T_C = 25^\circ C$	Continuous Drain Current	10.4	A
I_D @ $V_{GS} = 12V, T_C = 100^\circ C$	Continuous Drain Current	6.5	
I_{DM}	Pulsed Drain Current ①	41.6	
P_D @ $T_C = 25^\circ C$	Max. Power Dissipation	151	W
	Linear Derating Factor	1.2	W/°C
V_{GS}	Gate-to-Source Voltage	±20	V
EAS	Single Pulse Avalanche Energy ②	500	mJ
I_{AR}	Avalanche Current ①	10.4	A
EAR	Repetitive Avalanche Energy ①	15.1	mJ
dv/dt	Peak Diode Recovery dv/dt ③	4.0	V/ns
T_J	Operating Junction	-55 to 150	°C
T_{STG}	Storage Temperature Range		
	Lead Temperature	300 (0.063 in. (1.6mm) from case for 10 sec.)	
	Weight	9.3 (typical)	g

Product Summary

Part Number	BV_{DSS}	$R_{DS(on)}$	I_D
IRHM2C50SE	600V	0.60Ω	10.4A
IRHM7C50SE	600V	0.60Ω	10.4A

Features:

- Radiation Hardened up to 1×10^6 Rads (Si)
- Single Event Burnout (SEB) Hardened
- Single Event Gate Rupture (SEGR) Hardened
- Gamma Dot (Flash X-Ray) Hardened
- Neutron Tolerant
- Identical Pre- and Post-Electrical Test Conditions
- Repetitive Avalanche Rating
- Dynamic dv/dt Rating
- Simple Drive Requirements
- Ease of Paralleling
- Hermetically Sealed
- Electrically Isolated
- Ceramic Eyelets

Pre-Irradiation

Electrical Characteristics @ Tj = 25°C (Unless Otherwise Specified)

	Parameter	Min	Typ	Max	Units	Test Conditions
BVDSS	Drain-to-Source Breakdown Voltage	600	—	—	V	VGS = 0V, ID = 1.0mA
ΔBVDSS/ΔTj	Temperature Coefficient of Breakdown Voltage	—	0.6	—	V/°C	Reference to 25°C, ID = 1.0mA
RDS(on)	Static Drain-to-Source On-State Resistance	—	—	0.60	Ω	VGS = 12V, ID = 6.5A ④
		—	—	0.65		VGS = 12V, ID = 10.4A
VGS(th)	Gate Threshold Voltage	2.5	—	4.5	V	VDS = VGS, ID = 1.0mA
gfs	Forward Transconductance	3.0	—	—	S (τ)	VDS > 15V, IDS = 6.5A ④
IDSS	Zero Gate Voltage Drain Current	—	—	50	μA	VDS = 0.8 x Max Rating, VGS = 0V
		—	—	250		VDS = 0.8 x Max Rating, VGS = 0V, Tj = 125°C
IGSS	Gate-to-Source Leakage Forward	—	—	100	nA	VGS = 20V
IGSS	Gate-to-Source Leakage Reverse	—	—	-100		VGS = -20V
Qg	Total Gate Charge	—	—	150	nC	VGS = 12V, ID = 10.4A
Qgs	Gate-to-Source Charge	—	—	30		VDS = Max Rating x 0.5
Qgd	Gate-to-Drain ('Miller') Charge	—	—	75		
td(on)	Turn-On Delay Time	—	—	28	ns	VDD = 300V, ID = 10.4A, RG = 2.35Ω
tr	Rise Time	—	—	75		
td(off)	Turn-Off Delay Time	—	—	75		
tf	Fall Time	—	—	75		
LD	Internal Drain Inductance	—	8.7	—	nH	Measured from drain lead, 6mm (0.25 in) from package to center of die.
LS	Internal Source Inductance	—	8.7	—		Measured from source lead, 6mm (0.25 in) from package to source bonding pad.
Ciss	Input Capacitance	—	2510	—	pF	VGS = 0V, VDS = 25V f = 1.0MHz
Coss	Output Capacitance	—	400	—		
Crss	Reverse Transfer Capacitance	—	110	—		

Source-Drain Diode Ratings and Characteristics

	Parameter	Min	Typ	Max	Units	Test Conditions
IS	Continuous Source Current (Body Diode)	—	—	10.4	A	Modified MOSFET symbol showing the integrated reverse-pn junction rectifier.
ISM	Pulse Source Current (Body Diode) ①	—	—	41.6		
VSD	Diode Forward Voltage	—	—	1.6	V	Tj = 25°C, IS = 10.4A, VGS = 0V ④
trr	Reverse Recovery Time	—	—	750	ns	Tj = 25°C, IF = 10.4A, di/dt ≤ 100A/μs
QRR	Reverse Recovery Charge	—	—	9.8	μC	VDD ≤ 50V ④
ton	Forward Turn-On Time	Intrinsic turn-on time is negligible. Turn-on speed is substantially controlled by LS + LD.				

Thermal Resistance

	Parameter	Min	Typ	Max	Units	Test Conditions
RthJC	Junction-to-Case	—	—	0.83	°C/W	Typical socket mount
RthCS	Case-to-Sink	—	0.21	—		
RthJA	Junction-to-Ambient	—	—	48		

Radiation Performance of Rad Hard HEXFETs

International Rectifier Radiation Hardened HEXFETs are tested to verify their hardness capability. The hardness assurance program at International Rectifier comprises 3 radiation environments.

Every manufacturing lot is tested in a low dose rate (total dose) environment per MIL-STD-750, test method 1019 condition A. International Rectifier has imposed a standard gate condition of 12 volts per note 5 and a V_{DS} bias condition equal to 80% of the device rated voltage per note 6. Pre and Post-irradiation limits of the devices irradiated to 0.5×10^5 Rads (Si) and 1×10^5 Rads (Si) are identical and presented in Table 1, column 1, IRHM2C50SE and column 2, IRHM7C50SE. The values in Table 1 will be

met for either of the two low dose rate test circuits that are used. Both pre- and post-irradiation performance are tested and specified using the same drive circuitry and test conditions in order to provide a direct comparison. It should be noted that at a radiation level of 1×10^5 Rads (Si) the only parameter limit change is V_{GSTh} minimum.

High dose rate testing may be done on a special request basis using a dose rate up to 1×10^{12} Rads (Si)/Sec (See Table 2).

International Rectifier radiation hardened HEXFETs have been characterized in heavy ion Single Event Effects (SEE) environments. Single Event Effects characterization is shown in Table 3.

Table 1. Low Dose Rate ⑤ ⑥

	Parameter	IRHM2C50SE		IRHM7C50SE		Units	Test Conditions ⑧
		50 K Rads (Si)		100 K Rads (Si)			
		Min	Max	Min	Max		
V_{DSS}	Drain-to-Source Breakdown Voltage	600	—	600	—	V	$V_{GS} = 0V, I_D = 1.0mA$
$V_{GS(th)}$	Gate Threshold Voltage ④	2.5	4.5	2.0	4.5		$V_{GS} = V_{DS}, I_D = 1.0mA$
I_{GSS}	Gate-to-Source Leakage Forward	—	100	—	100	nA	$V_{GS} = 20V$
I_{GSS}	Gate-to-Source Leakage Reverse	—	-100	—	-100		$V_{GS} = -20V$
I_{DSS}	Zero Gate Voltage Drain Current	—	50	—	50	μA	$V_{DS}=0.8 \times \text{Max Rating}, V_{GS} = 0V$
$R_{DS(on)1}$	Static Drain-to-Source On-State Resistance One ④	—	0.6	—	0.6	Ω	$V_{GS} = 12V, I_D = 6.5A$
V_{SD}	Diode Forward Voltage ④	—	1.6	—	1.6	V	$T_C = 25^\circ C, I_S = 10.4A, V_{GS} = 0V$

Table 2. High Dose Rate ⑦

	Parameter	10^{11} Rads (Si)/sec			10^{12} Rads (Si)/sec			Units	Test Conditions
		Min	Typ	Max	Min	Typ	Max		
V_{DSS}	Drain-to-Source Voltage	—	—	480	—	—	480	V	Applied drain-to-source voltage during gamma-dot
I_{PP}		—	6.4	—	—	6.4	—	A	Peak radiation induced photo-current
di/dt		—	16	—	—	2.3	—	A/ μ sec	Rate of rise of photo-current
L_1		—	20	—	—	137	—	μH	Circuit inductance required to limit di/dt

Table 3. Single Event Effects

Ion	LET (Si) (MeV/mg/cm ²)	Fluence (ions/cm ²)	Range (μm)	V_{DS} Bias (V)	V_{GS} Bias (V)
Ni	28	1×10^5	~28	480	-5

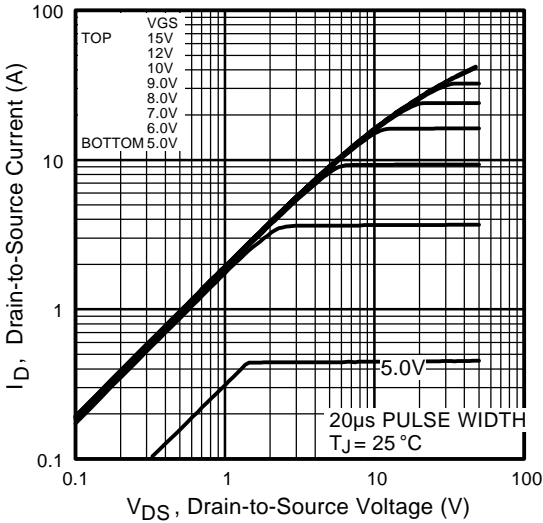

Fig 1. Typical Output Characteristics

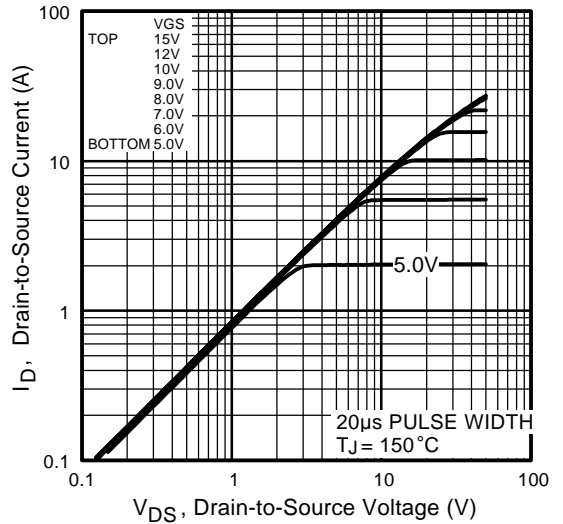

Fig 2. Typical Output Characteristics

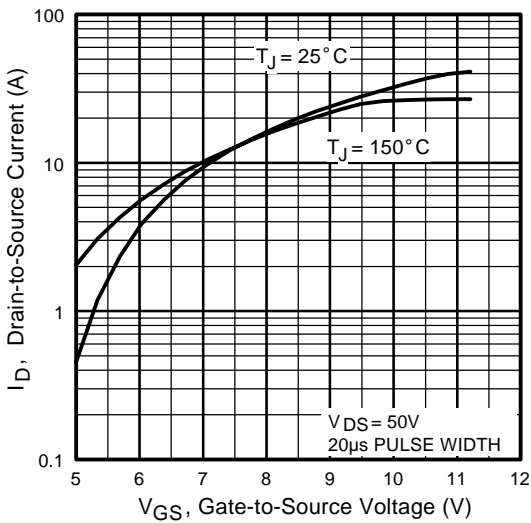

Fig 3. Typical Transfer Characteristics

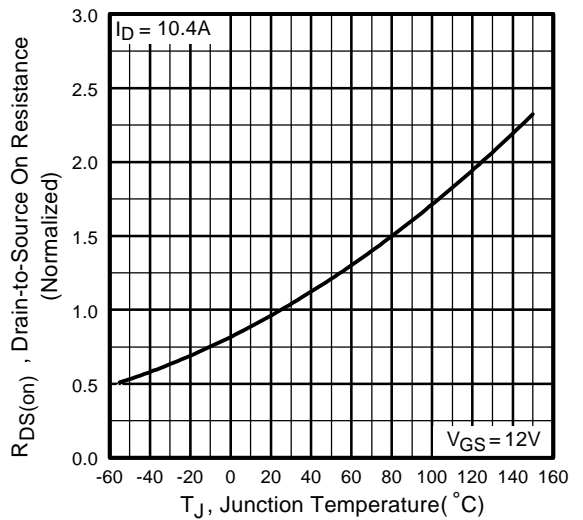

Fig 4. Normalized On-Resistance Vs. Temperature

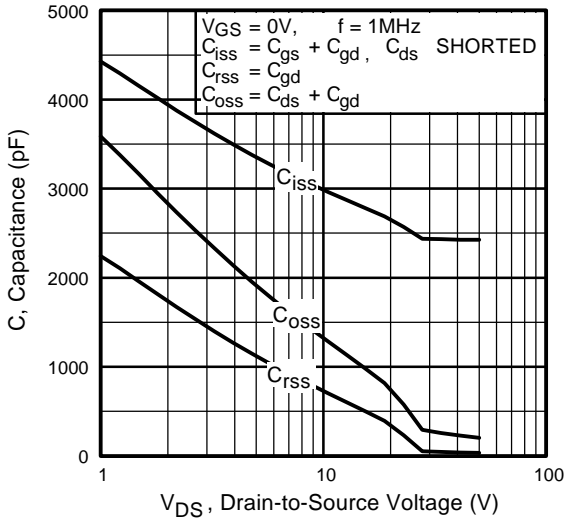

Fig 5. Typical Capacitance Vs. Drain-to-Source Voltage

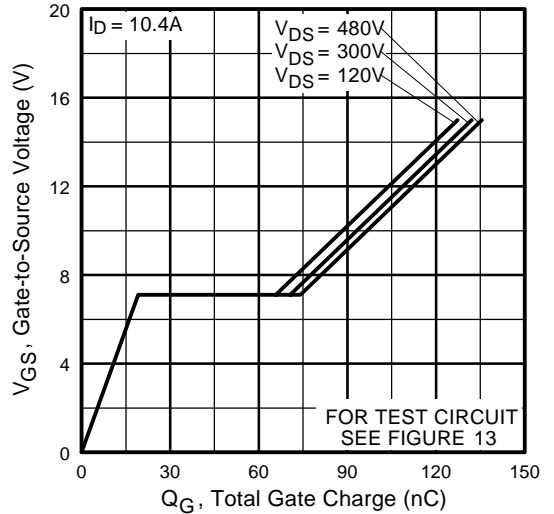

Fig 6. Typical Gate Charge Vs. Gate-to-Source Voltage

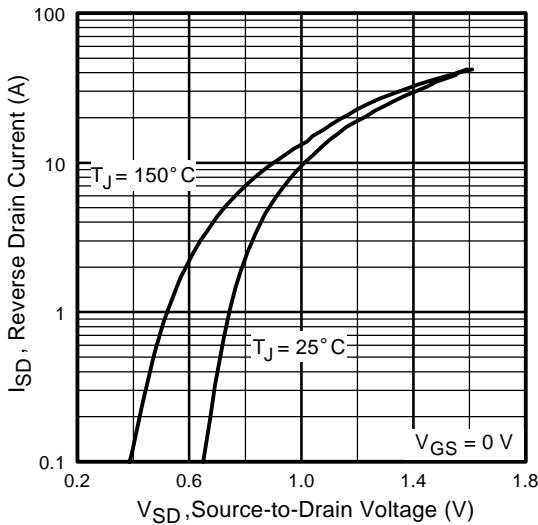

Fig 7. Typical Source-Drain Diode Forward Voltage

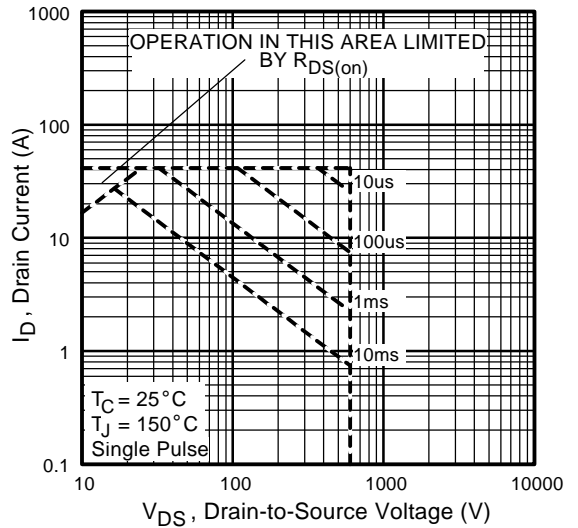

Fig 8. Maximum Safe Operating Area

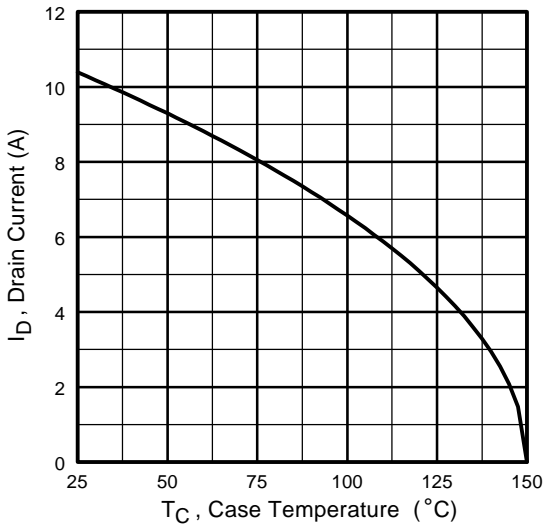

Fig 9. Maximum Drain Current Vs. Case Temperature

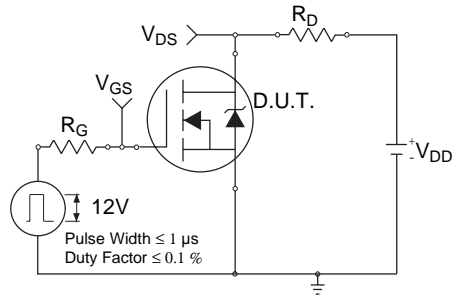

Fig 10a. Switching Time Test Circuit

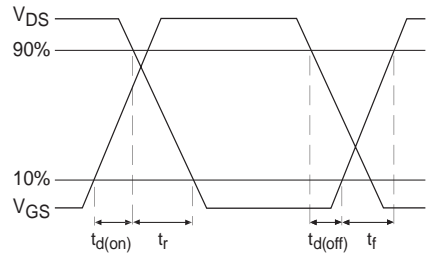

Fig 10b. Switching Time Waveforms

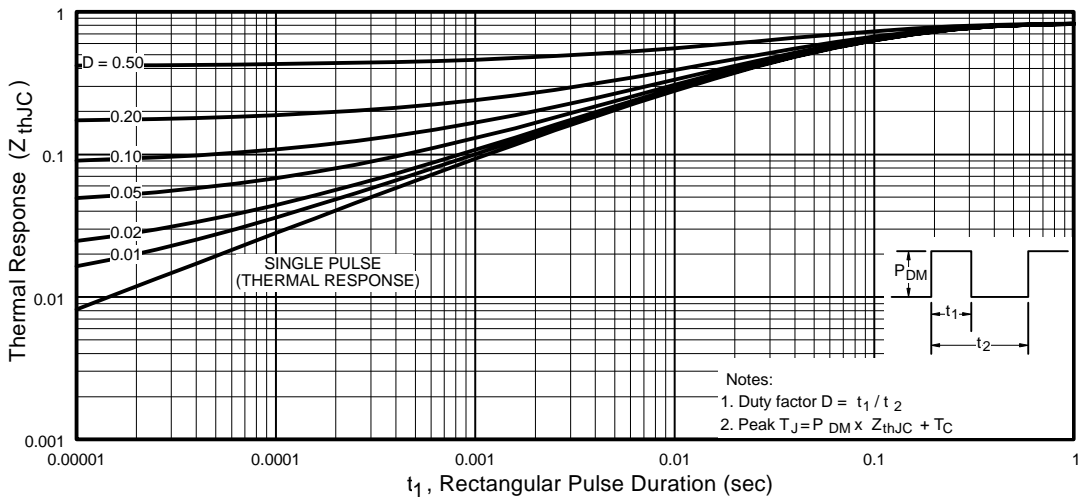

Fig 11. Maximum Effective Transient Thermal Impedance, Junction-to-Case

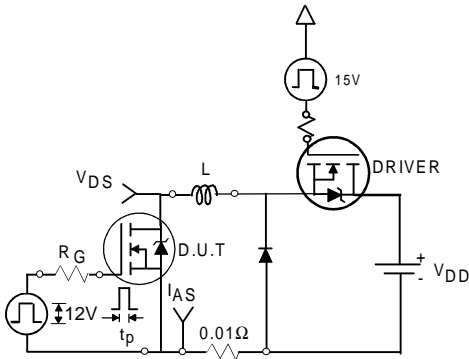

Fig 12a. Unclamped Inductive Test Circuit

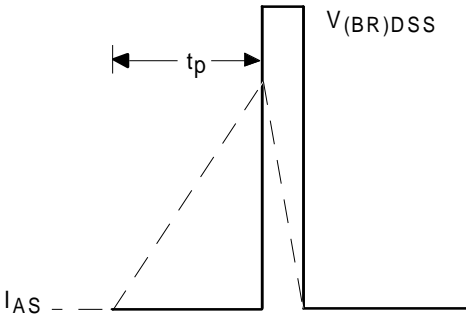

Fig 12b. Unclamped Inductive Waveforms

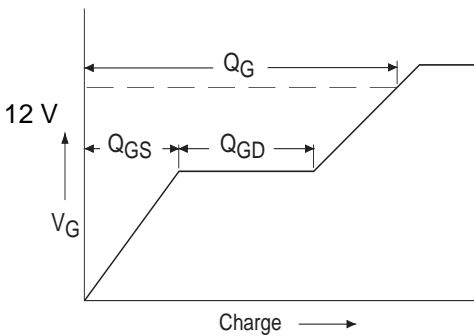

Fig 13a. Basic Gate Charge Waveform

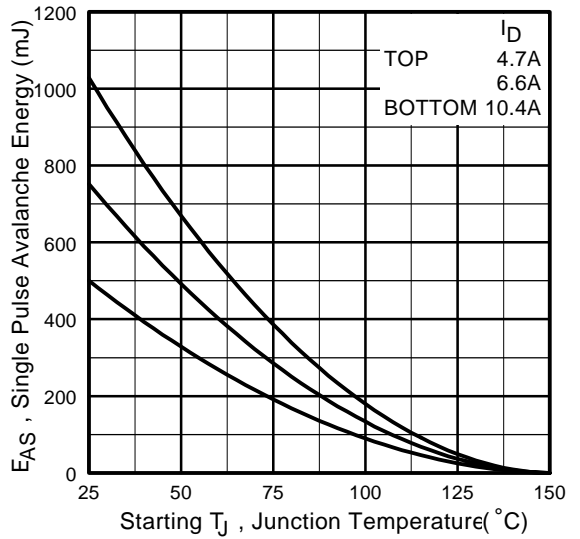

Fig 12c. Maximum Avalanche Energy Vs. Drain Current

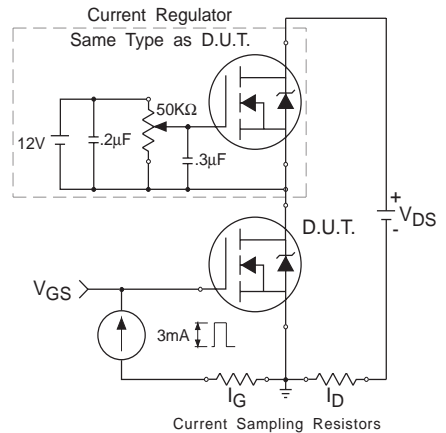
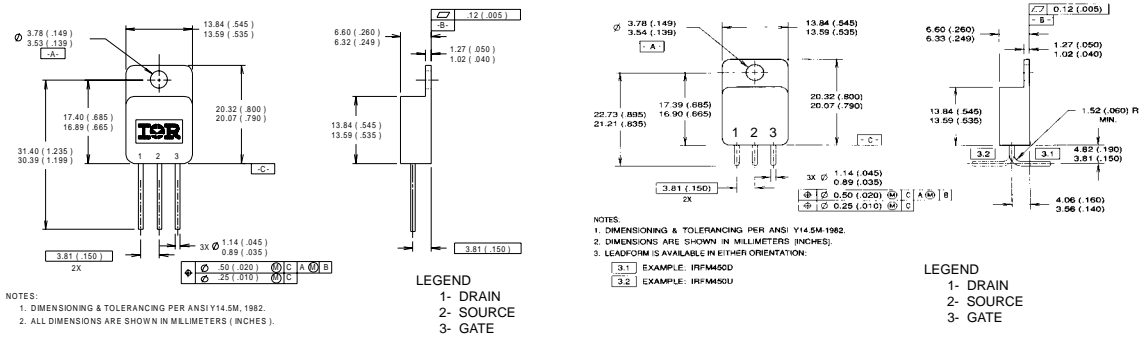

Fig 13b. Gate Charge Test Circuit

- ① Repetitive Rating; Pulse width limited by maximum junction temperature. Refer to current HEXFET reliability report.
- ② @ Starting $T_J = 25^\circ\text{C}$,
 $E_{AS} = [0.5 * L * (I_L^2)]$, $V_{DD} = 50\text{V}$
 Peak $I_L = 10.4\text{A}$, $V_{GS} = 12\text{V}$, $25 \leq R_G \leq 200\Omega$
- ③ $I_{SD} \leq 10.4\text{A}$, $di/dt \leq 400\text{A}/\mu\text{s}$,
 $V_{DD} \leq BV_{DSS}$, $T_J \leq 150^\circ\text{C}$
 Suggested $R_G = 2.35\Omega$
- ④ Pulse width $\leq 300 \mu\text{s}$; Duty Cycle $\leq 2\%$
- ⑤ **Total Dose Irradiation with V_{GS} Bias.**
 12 volt V_{GS} applied and $V_{DS} = 0$ during irradiation per MIL-STD-750, method 1019, condition A.
- ⑥ **Total Dose Irradiation with V_{DS} Bias.**
 $V_{DS} = 0.8$ rated BV_{DSS} (pre-irradiation) applied and $V_{GS} = 0$ during irradiation per MIL-STD -750, method 1019, condition A.
- ⑦ This test is performed using a flash x-ray source operated in the e-beam mode (energy $\sim 2.5\text{ MeV}$), 30 nsec pulse.
- ⑧ All Pre-Irradiation and Post-Irradiation test conditions are **identical** to facilitate direct comparison for circuit applications.

Case Outline and Dimensions — TO-254AA



Conforms to JEDEC Outline TO-254AA
 Dimensions in Millimeters and (Inches)

CAUTION

BERYLLIA WARNING PER MIL-PRF-19500

Package containing beryllia shall not be ground, sandblasted, machined, or have other operations performed on them which will produce beryllia or beryllium dust. Furthermore, beryllium oxide packages shall not be placed in acids that will produce fumes containing beryllium.



WORLD HEADQUARTERS: 233 Kansas St., El Segundo, California 90245, Tel: (310) 322 3331

IR GREAT BRITAIN: Hurst Green, Oxted, Surrey RH8 9BB, UK Tel: ++ 44 1883 732020

IR CANADA: 15 Lincoln Court, Brampton, Ontario L6T3Z2, Tel: (905) 453 2200

IR GERMANY: Saalburgstrasse 157, 61350 Bad Homburg Tel: ++ 49 6172 96590

IR ITALY: Via Liguria 49, 10071 Borgaro, Torino Tel: ++ 39 11 451 0111

IR FAR EAST: K&H Bldg., 2F, 30-4 Nishi-Ikebukuro 3-Chome, Toshima-Ku, Tokyo Japan 171 Tel: 81 3 3983 0086

IR SOUTHEAST ASIA: 1 Kim Seng Promenade, Great World City West Tower, 13-11, Singapore 237994 Tel: ++ 65 838 4630

IR TAIWAN: 16 Fl. Suite D. 207, Sec. 2, Tun Haw South Road, Taipei, 10673, Taiwan Tel: 886-2-2377-9936

<http://www.irf.com/> Data and specifications subject to change without notice. 1/99



LittleDiode supplies new, hard to find or obsolete electronic components and semiconductors all over the world.

With over two million different components listed you are sure to find the part you need.

Feel free to visit us today at our online store:

LittleDiode.com

Looking forward to providing you with the best possible service.