

WARP2 SERIES IGBT WITH
ULTRAFAST SOFT RECOVERY DIODE

Applications

- Telecom and Server SMPS
- PFC and ZVS SMPS Circuits
- Uninterruptable Power Supplies
- Consumer Electronics Power Supplies

Features

- NPT Technology, Positive Temperature Coefficient
- Lower $V_{CE(SAT)}$
- Lower Parasitic Capacitances
- Minimal Tail Current
- HEXFRED Ultra Fast Soft-Recovery Co-Pack Diode
- Tighter Distribution of Parameters
- Higher Reliability

Benefits

- Parallel Operation for Higher Current Applications
- Lower Conduction Losses and Switching Losses
- Higher Switching Frequency up to 150kHz

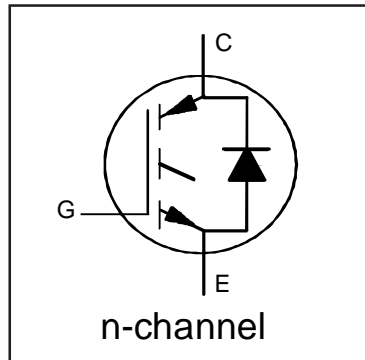

$V_{CES} = 600V$
 $V_{CE(on)} \text{ typ.} = 2.00V$
 @ $V_{GE} = 15V$ $I_C = 33A$

Equivalent MOSFET Parameters①

$R_{CE(on)} \text{ typ.} = 61m\Omega$
 I_D (FET equivalent) = 50A

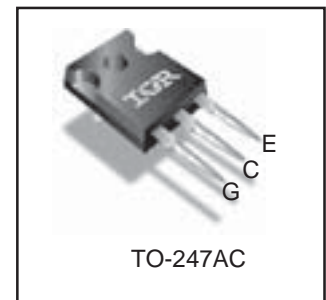

Absolute Maximum Ratings

| | Parameter | Max. | Units | |
|---------------------------|--|-----------------------------------|------------|---|
| V_{CES} | Collector-to-Emitter Voltage | 600 | V | |
| $I_C @ T_C = 25^\circ C$ | Continuous Collector Current | 75 | A | |
| $I_C @ T_C = 100^\circ C$ | Continuous Collector Current | 45 | | |
| I_{CM} | Pulse Collector Current (Ref. Fig. C.T.4) | 150 | | |
| I_{LM} | Clamped Inductive Load Current ② | 150 | | |
| $I_F @ T_C = 25^\circ C$ | Diode Continuous Forward Current | 40 | | |
| $I_F @ T_C = 100^\circ C$ | Diode Continuous Forward Current | 15 | | |
| I_{FRM} | Maximum Repetitive Forward Current ③ | 60 | | |
| V_{GE} | Gate-to-Emitter Voltage | ± 20 | | V |
| $P_D @ T_C = 25^\circ C$ | Maximum Power Dissipation | 390 | | W |
| $P_D @ T_C = 100^\circ C$ | Maximum Power Dissipation | 156 | | |
| T_J | Operating Junction and Storage Temperature Range | -55 to +150 | $^\circ C$ | |
| T_{STG} | | | | |
| | Soldering Temperature for 10 sec. | 300 (0.063 in. (1.6mm) from case) | | |
| | Mounting Torque, 6-32 or M3 Screw | 10 lbf-in (1.1 N-m) | | |

Thermal Resistance

| | Parameter | Min. | Typ. | Max. | Units |
|-------------------------|--|------|------------|------|--------------|
| $R_{\theta JC}$ (IGBT) | Thermal Resistance Junction-to-Case-(each IGBT) | — | — | 0.32 | $^\circ C/W$ |
| $R_{\theta JC}$ (Diode) | Thermal Resistance Junction-to-Case-(each Diode) | — | — | 1.7 | |
| $R_{\theta CS}$ | Thermal Resistance, Case-to-Sink (flat, greased surface) | — | 0.24 | — | |
| $R_{\theta JA}$ | Thermal Resistance, Junction-to-Ambient (typical socket mount) | — | — | 40 | |
| | Weight | — | 6.0 (0.21) | — | g (oz) |

Electrical Characteristics @ T_J = 25°C (unless otherwise specified)

| | Parameter | Min. | Typ. | Max. | Units | Conditions | Ref.Fig |
|--|---|------|------|------|-------|--|------------|
| V _{(BR)CES} | Collector-to-Emitter Breakdown Voltage | 600 | — | — | V | V _{GE} = 0V, I _C = 500μA | |
| ΔV _{(BR)CES} /ΔT _J | Temperature Coeff. of Breakdown Voltage | — | 0.31 | — | V/°C | V _{GE} = 0V, I _C = 1mA (25°C-125°C) | |
| R _G | Internal Gate Resistance | — | 1.7 | — | Ω | 1MHz, Open Collector | |
| V _{CE(on)} | Collector-to-Emitter Saturation Voltage | — | 2.00 | 2.35 | V | I _C = 33A, V _{GE} = 15V | 4, 5,6,8,9 |
| | | — | 2.45 | 2.85 | | I _C = 50A, V _{GE} = 15V | |
| | | — | 2.60 | 2.95 | | I _C = 33A, V _{GE} = 15V, T _J = 125°C | |
| | | — | 3.20 | 3.60 | | I _C = 50A, V _{GE} = 15V, T _J = 125°C | |
| V _{GE(th)} | Gate Threshold Voltage | 3.0 | 4.0 | 5.0 | V | I _C = 250μA | 7,8,9 |
| ΔV _{GE(th)} /ΔT _J | Threshold Voltage temp. coefficient | — | -10 | — | mV/°C | V _{CE} = V _{GE} , I _C = 1.0mA | |
| g _{fe} | Forward Transconductance | — | 41 | — | S | V _{CE} = 50V, I _C = 33A, PW = 80μs | |
| I _{CES} | Collector-to-Emitter Leakage Current | — | 5.0 | 500 | μA | V _{GE} = 0V, V _{CE} = 600V | |
| | | — | 1.0 | — | mA | V _{GE} = 0V, V _{CE} = 600V, T _J = 125°C | |
| V _{FM} | Diode Forward Voltage Drop | — | 1.30 | 1.70 | V | I _F = 15A, V _{GE} = 0V | 10 |
| | | — | 1.20 | 1.60 | | I _F = 15A, V _{GE} = 0V, T _J = 125°C | |
| I _{GES} | Gate-to-Emitter Leakage Current | — | — | ±100 | nA | V _{GE} = ±20V, V _{CE} = 0V | |

Switching Characteristics @ T_J = 25°C (unless otherwise specified)

| | Parameter | Min. | Typ. | Max. | Units | Conditions | Ref.Fig | |
|----------------------------|---|-------------|------|------|--|--|-------------|--------------------------|
| Q _g | Total Gate Charge (turn-on) | — | 205 | 308 | nC | I _C = 33A | 17 | |
| Q _{gc} | Gate-to-Collector Charge (turn-on) | — | 70 | 105 | | V _{CC} = 400V | CT1 | |
| Q _{ge} | Gate-to-Emitter Charge (turn-on) | — | 30 | 45 | | V _{GE} = 15V | | |
| E _{on} | Turn-On Switching Loss | — | 255 | 305 | μJ | I _C = 33A, V _{CC} = 390V | CT3 | |
| E _{off} | Turn-Off Switching Loss | — | 375 | 445 | | V _{GE} = +15V, R _G = 3.3Ω, L = 200μH | | |
| E _{total} | Total Switching Loss | — | 630 | 750 | | T _J = 25°C ④ | | |
| t _{d(on)} | Turn-On delay time | — | 30 | 40 | ns | I _C = 33A, V _{CC} = 390V | CT3 | |
| t _r | Rise time | — | 10 | 15 | | V _{GE} = +15V, R _G = 3.3Ω, L = 200μH | | |
| t _{d(off)} | Turn-Off delay time | — | 130 | 150 | | T _J = 25°C ④ | | |
| t _f | Fall time | — | 11 | 15 | | | | |
| E _{on} | Turn-On Switching Loss | — | 580 | 700 | | I _C = 33A, V _{CC} = 390V | | CT3 |
| E _{off} | Turn-Off Switching Loss | — | 480 | 550 | V _{GE} = +15V, R _G = 3.3Ω, L = 200μH | 11,13 | | |
| E _{total} | Total Switching Loss | — | 1060 | 1250 | μJ | T _J = 125°C ④ | WF1,WF2 | |
| t _{d(on)} | Turn-On delay time | — | 26 | 35 | ns | I _C = 33A, V _{CC} = 390V | CT3 | |
| t _r | Rise time | — | 13 | 20 | | V _{GE} = +15V, R _G = 3.3Ω, L = 200μH | | |
| t _{d(off)} | Turn-Off delay time | — | 146 | 165 | | T _J = 125°C ④ | | |
| t _f | Fall time | — | 15 | 20 | | | | |
| E _{on} | Turn-On Switching Loss | — | 580 | 700 | | μJ | | T _J = 125°C ④ |
| C _{ies} | Input Capacitance | — | 3648 | — | pF | V _{GE} = 0V | 16 | |
| C _{oes} | Output Capacitance | — | 322 | — | | V _{CC} = 30V | | |
| C _{res} | Reverse Transfer Capacitance | — | 56 | — | | f = 1Mhz | | |
| C _{oes eff.} | Effective Output Capacitance (Time Related) ⑤ | — | 215 | — | | V _{GE} = 0V, V _{CE} = 0V to 480V | | 15 |
| C _{oes eff. (ER)} | Effective Output Capacitance (Energy Related) ⑤ | — | 163 | — | | | | |
| RBSOA | Reverse Bias Safe Operating Area | FULL SQUARE | | | | T _J = 150°C, I _C = 150A V _{CC} = 480V, V _p = 600V R _g = 22Ω, V _{GE} = +15V to 0V | 3 CT2 | |
| t _{rr} | Diode Reverse Recovery Time | — | 42 | 60 | ns | T _J = 25°C I _F = 15A, V _R = 200V, | 19 | |
| | | — | 74 | 120 | | T _J = 125°C di/dt = 200A/μs | | |
| Q _{rr} | Diode Reverse Recovery Charge | — | 80 | 180 | nC | T _J = 25°C I _F = 15A, V _R = 200V, | 21 | |
| | | — | 220 | 600 | | T _J = 125°C di/dt = 200A/μs | | |
| I _{rr} | Peak Reverse Recovery Current | — | 4.0 | 6.0 | A | T _J = 25°C I _F = 15A, V _R = 200V, | 19,20,21,22 | |
| | | — | 6.5 | 10 | | T _J = 125°C di/dt = 200A/μs | | |

Notes:

① R_{CE(on)} typ. = equivalent on-resistance = V_{CE(on)} typ. / I_C, where V_{CE(on)} typ. = 2.00V and I_C = 33A. I_D (FET Equivalent) is the equivalent MOSFET I_D rating @ 25°C for applications up to 150kHz. These are provided for comparison purposes (only) with equivalent MOSFET solutions.

② V_{CC} = 80% (V_{CES}), V_{GE} = 15V, L = 28 μH, R_G = 22 Ω.

③ Pulse width limited by max. junction temperature.

④ Energy losses include "tail" and diode reverse recovery, Data generated with use of Diode 30ETH06.

⑤ C_{oes eff.} is a fixed capacitance that gives the same charging time as C_{oes} while V_{CE} is rising from 0 to 80% V_{CES}.

C_{oes eff. (ER)} is a fixed capacitance that stores the same energy as C_{oes} while V_{CE} is rising from 0 to 80% V_{CES}.

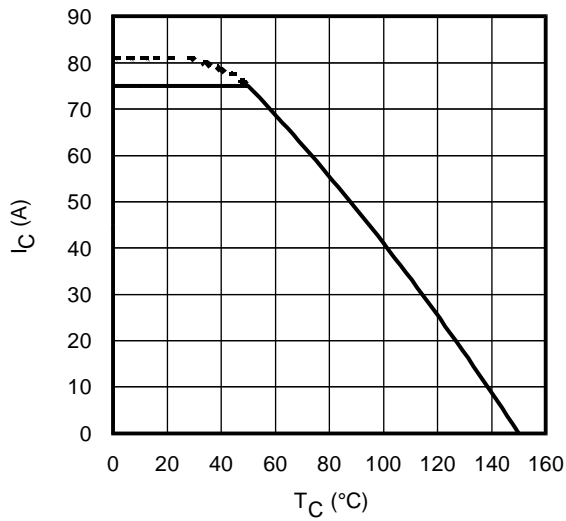

Fig. 1 - Maximum DC Collector Current vs. Case Temperature

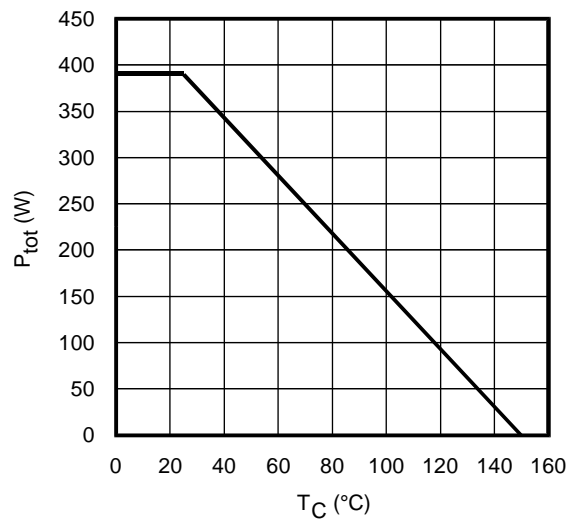

Fig. 2 - Power Dissipation vs. Case Temperature

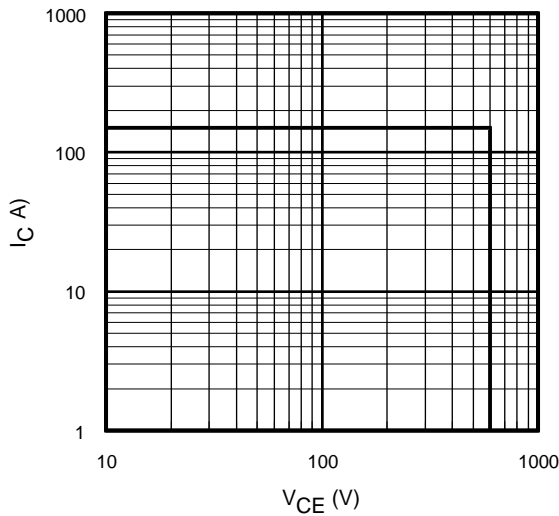

Fig. 3 - Reverse Bias SOA
 $T_J = 150^\circ\text{C}$; $V_{GE} = 15\text{V}$

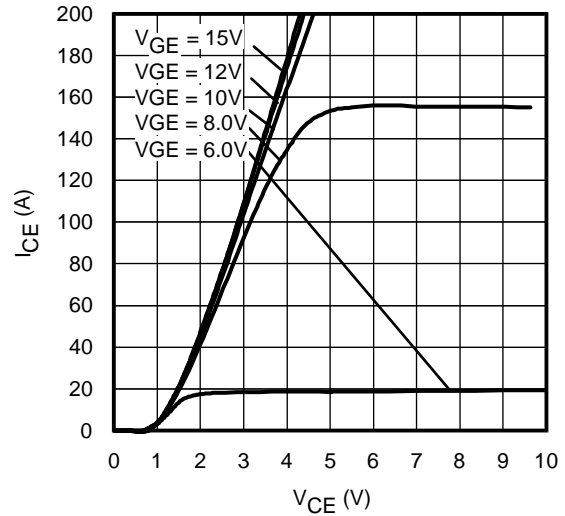

Fig. 4 - Typ. IGBT Output Characteristics
 $T_J = -40^\circ\text{C}$; $t_p = 80\mu\text{s}$

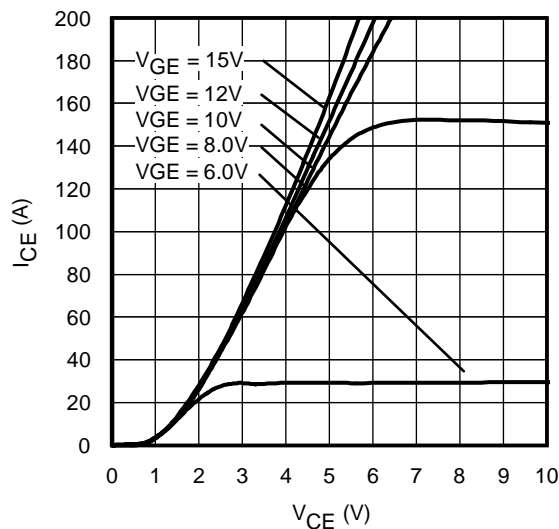

Fig. 5 - Typ. IGBT Output Characteristics
 $T_J = 25^\circ\text{C}$; $t_p = 80\mu\text{s}$

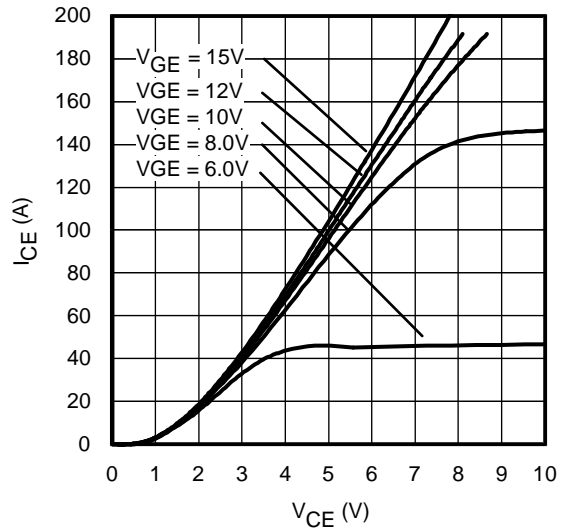

Fig. 6 - Typ. IGBT Output Characteristics
 $T_J = 125^\circ\text{C}$; $t_p = 80\mu\text{s}$

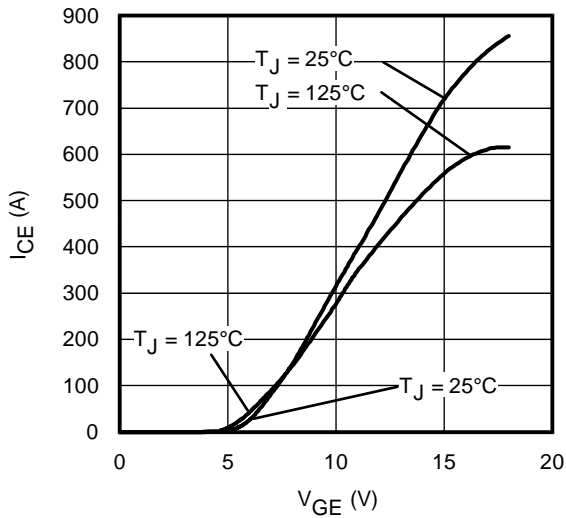

Fig. 7 - Typ. Transfer Characteristics
 $V_{CE} = 50V$; $t_p = 10\mu s$

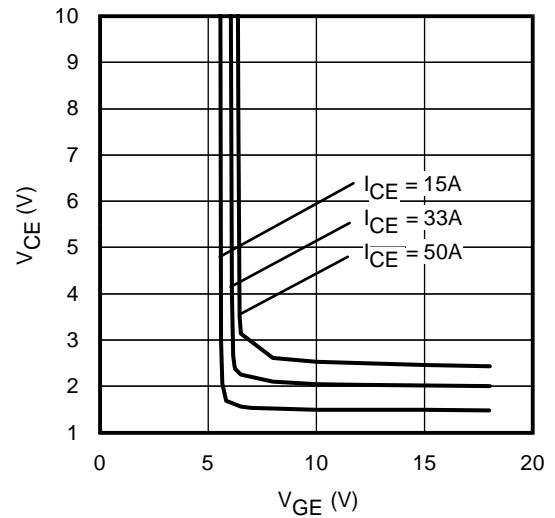

Fig. 8 - Typical V_{CE} vs. V_{GE}
 $T_J = 25^\circ C$

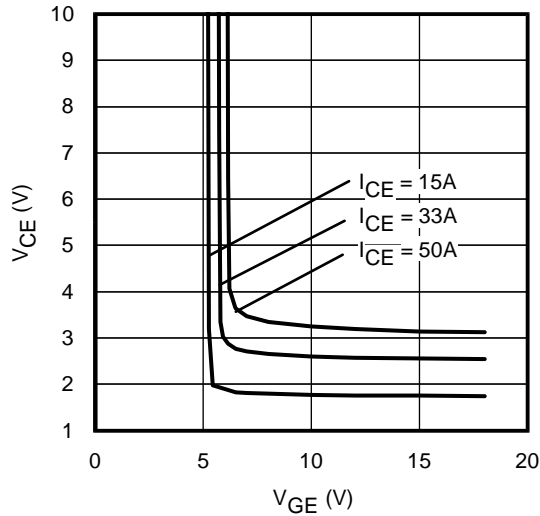

Fig. 9 - Typical V_{CE} vs. V_{GE}
 $T_J = 125^\circ C$

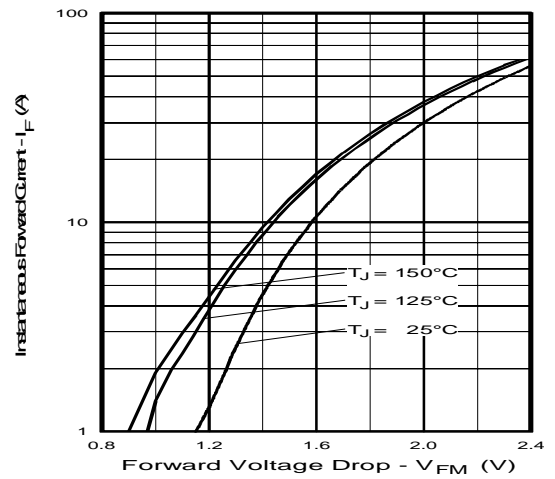

Fig. 10 - Typ. Diode Forward Characteristics
 $t_p = 80\mu s$

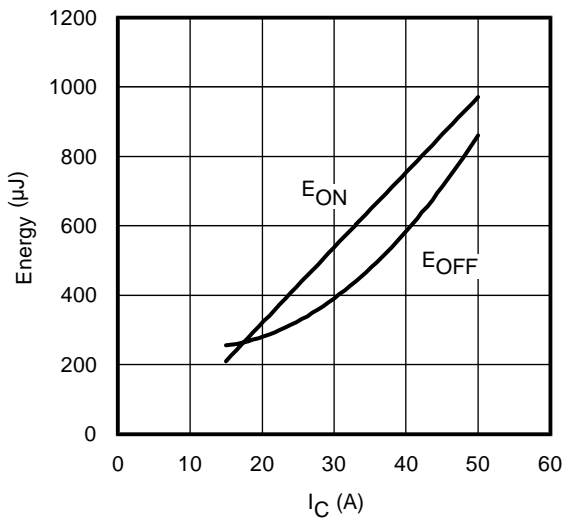

Fig. 11 - Typ. Energy Loss vs. I_C
 $T_J = 125^\circ C$; $L = 200\mu H$; $V_{CE} = 390V$; $R_G = 3.3\Omega$; $V_{GE} = 15V$.
Diode clamp used: 30ETH06 (See C.T.3)

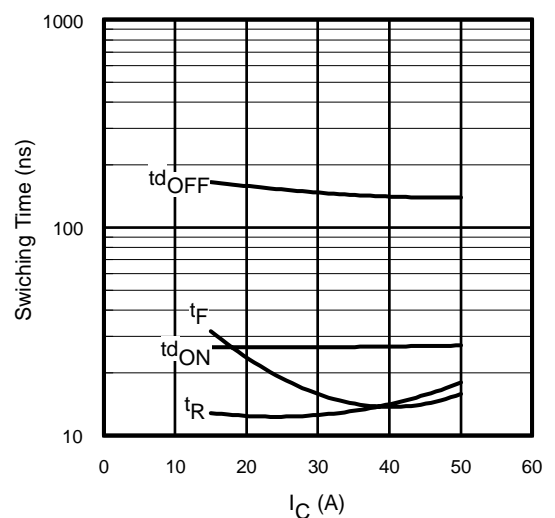

Fig. 12 - Typ. Switching Time vs. I_C
 $T_J = 125^\circ C$; $L = 200\mu H$; $V_{CE} = 390V$; $R_G = 3.3\Omega$; $V_{GE} = 15V$.
Diode clamp used: 30ETH06 (See C.T.3)

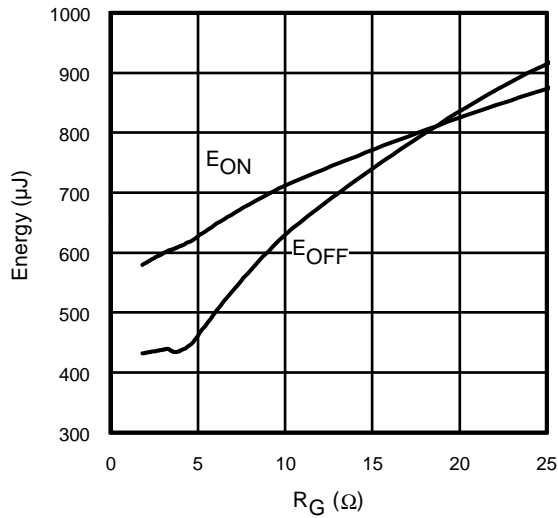

Fig. 13 - Typ. Energy Loss vs. R_G
 $T_J = 125^\circ\text{C}$; $L = 200\mu\text{H}$; $V_{CE} = 390\text{V}$; $I_{CE} = 33\text{A}$; $V_{GE} = 15\text{V}$
 Diode clamp used: 30ETH06 (See C.T.3)

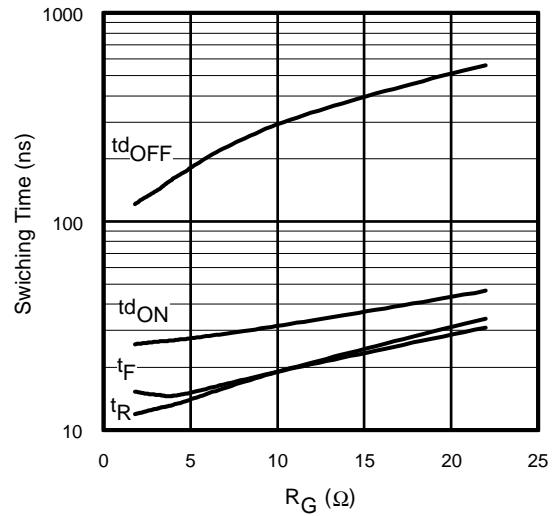
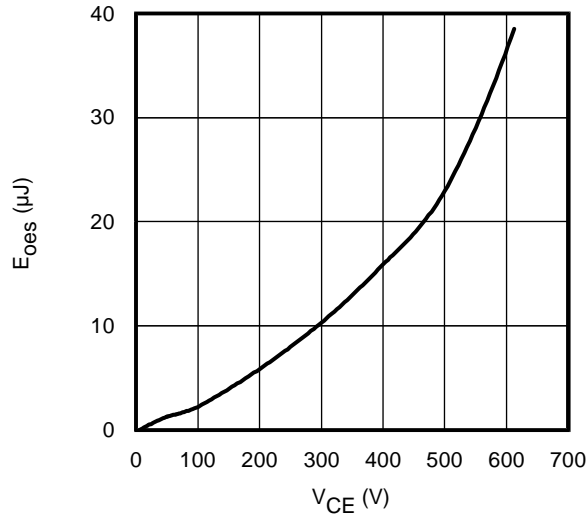

Fig. 14 - Typ. Switching Time vs. R_G
 $T_J = 125^\circ\text{C}$; $L = 200\mu\text{H}$; $V_{CE} = 390\text{V}$; $I_{CE} = 33\text{A}$; $V_{GE} = 15\text{V}$
 Diode clamp used: 30ETH06 (See C.T.3)



**Fig. 15- Typ. Output Capacitance
 Stored Energy vs. V_{CE}**

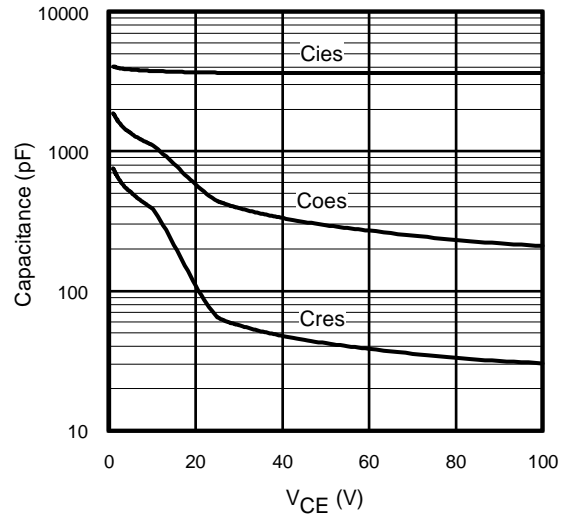

Fig. 16- Typ. Capacitance vs. V_{CE}
 $V_{GE} = 0\text{V}$; $f = 1\text{MHz}$

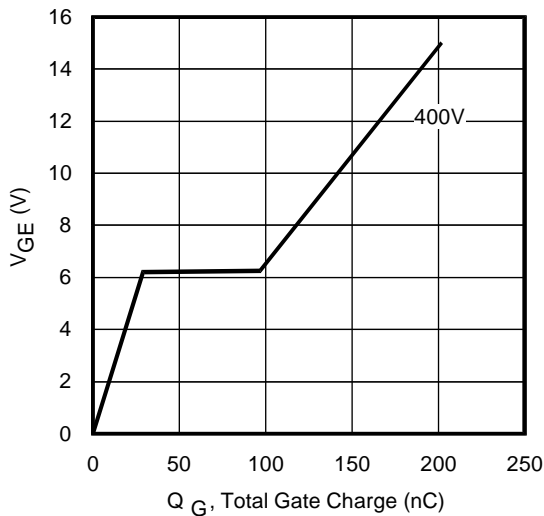
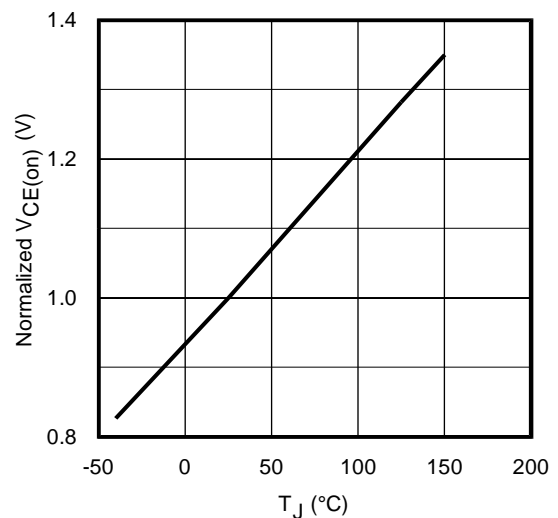

Fig. 17 - Typical Gate Charge vs. V_{GE}
 $I_{CE} = 33\text{A}$



**Fig. 18 - Normalized Typ. $V_{CE(on)}$
 vs. Junction Temperature**
 $I_C = 33\text{A}$, $V_{GE} = 15\text{V}$

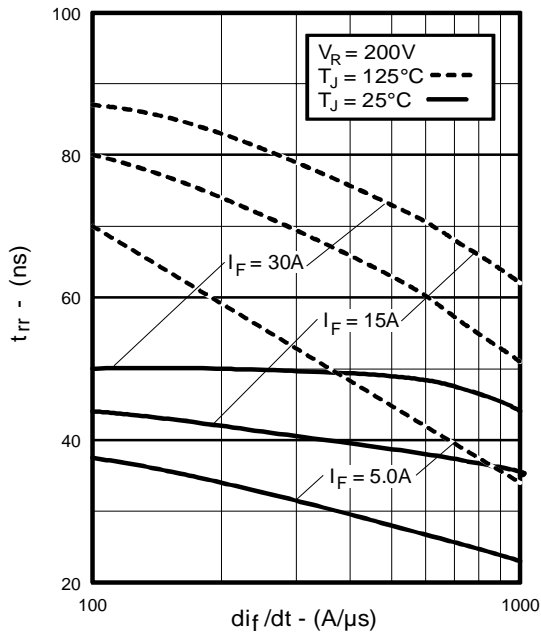

Fig. 19 - Typical Reverse Recovery vs. di_f/dt

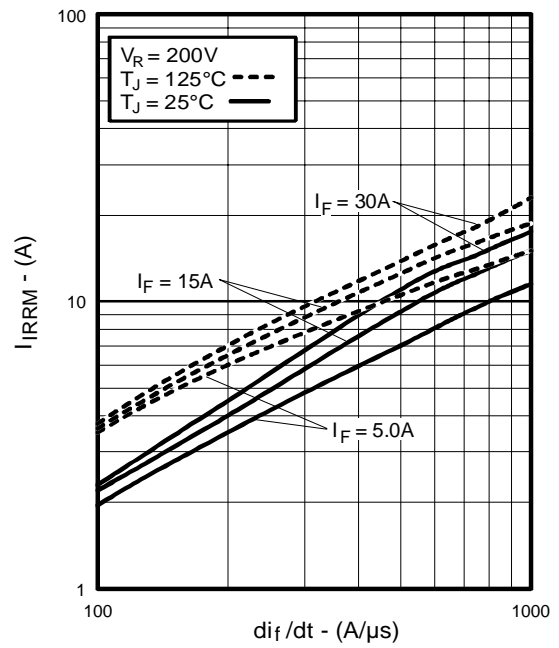

Fig. 20 - Typical Recovery Current vs. di_f/dt

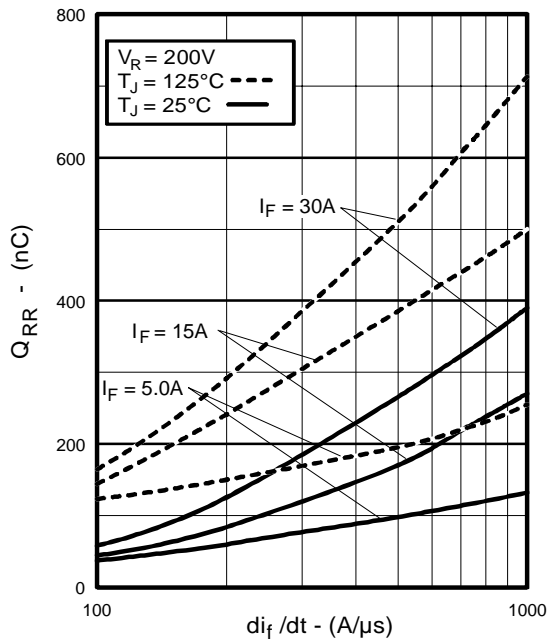

Fig. 21 - Typical Stored Charge vs. di_f/dt

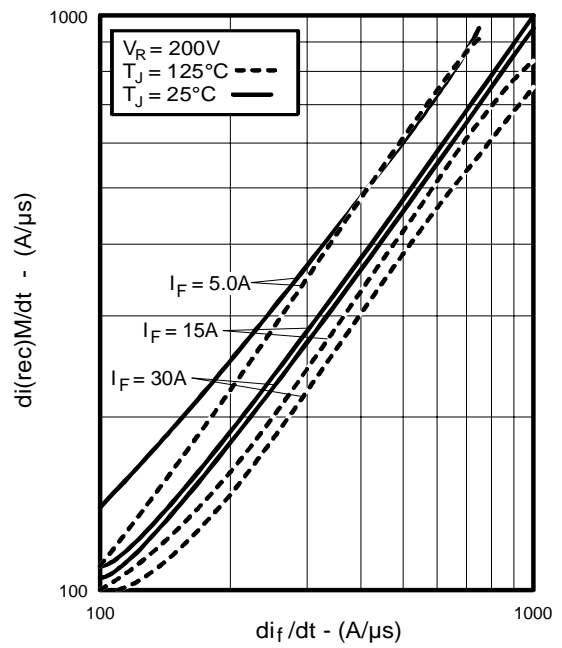

Fig. 22 - Typical $di_{(rec)M}/dt$ vs. di_f/dt

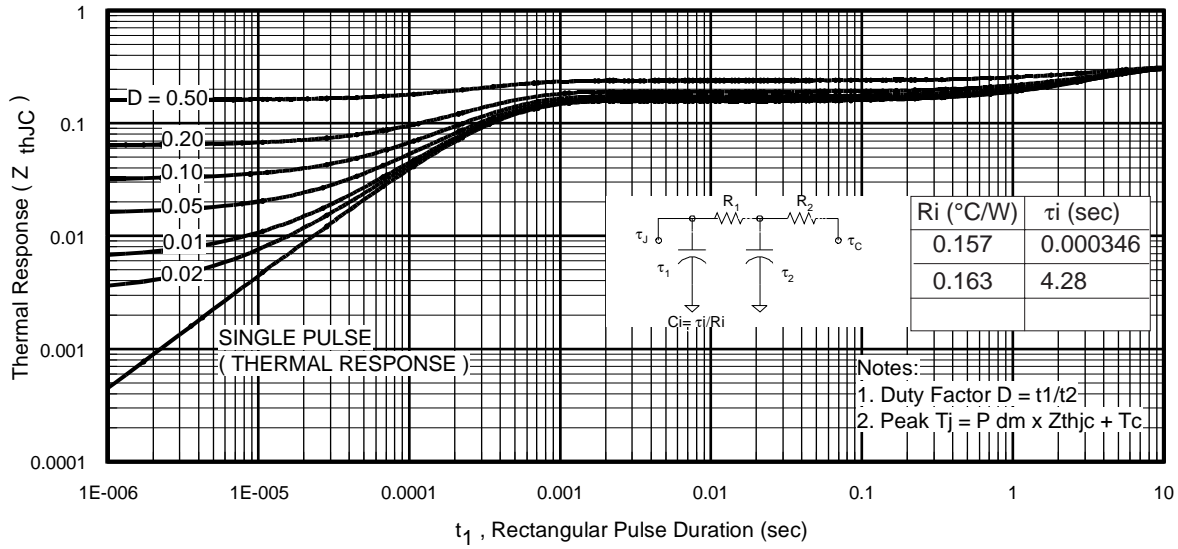

Fig. 23. Maximum Transient Thermal Impedance, Junction-to-Case (IGBT)

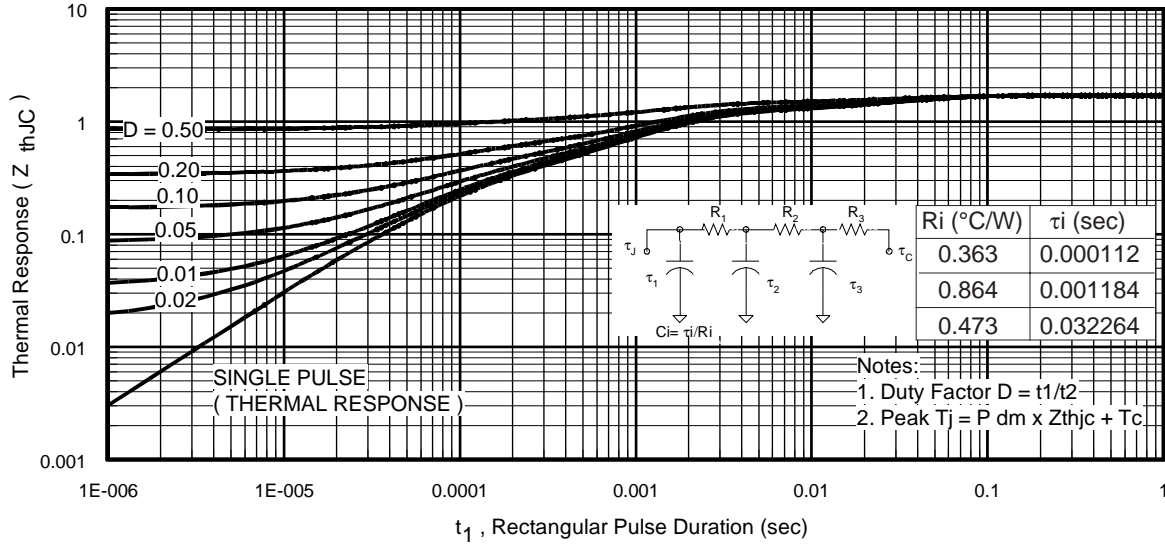

Fig. 24. Maximum Transient Thermal Impedance, Junction-to-Case (DIODE)

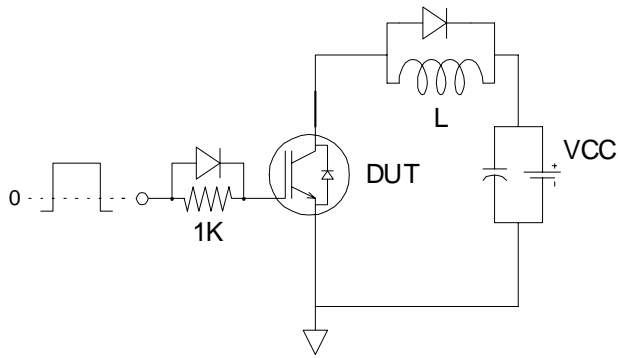

Fig.C.T.1 - Gate Charge Circuit (turn-off)

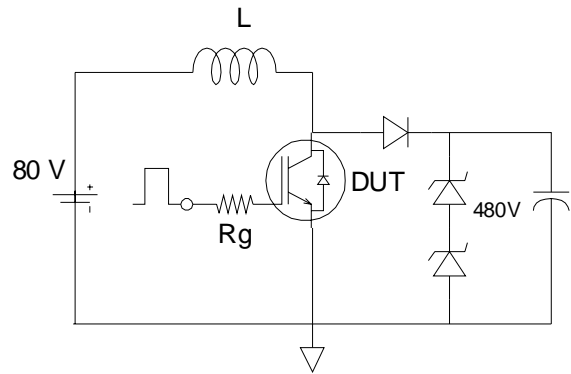

Fig.C.T.2 - RBSOA Circuit

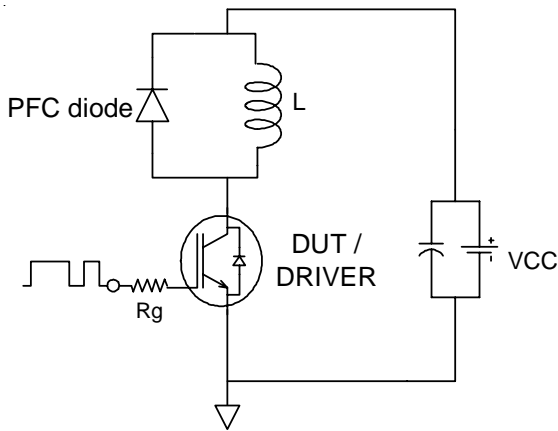

Fig.C.T.3 - Switching Loss Circuit

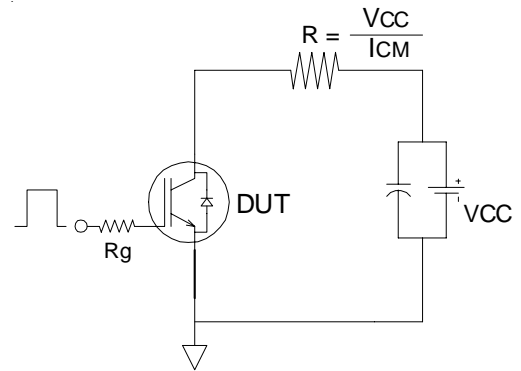

Fig.C.T.4 - Resistive Load Circuit

REVERSE RECOVERY CIRCUIT

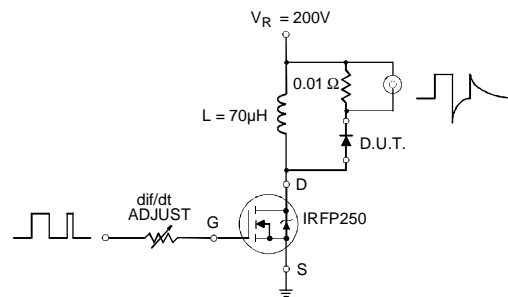

Fig. C.T.5 - Reverse Recovery Parameter Test Circuit

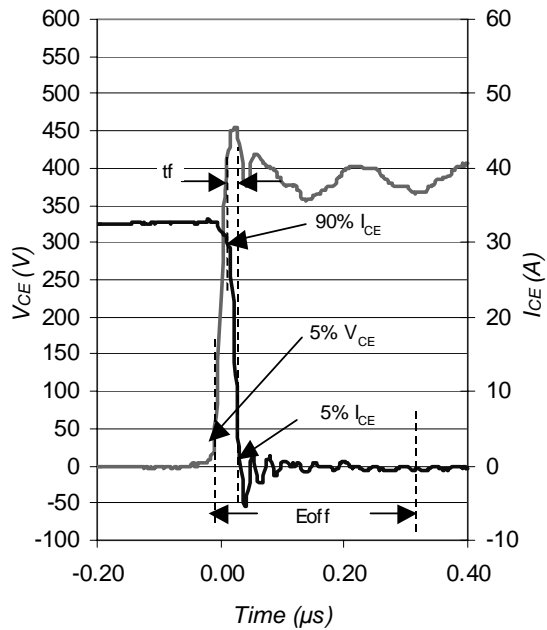

Fig. WF1 - Typ. Turn-off Loss Waveform
@ $T_J = 25^\circ\text{C}$ using Fig. CT.3

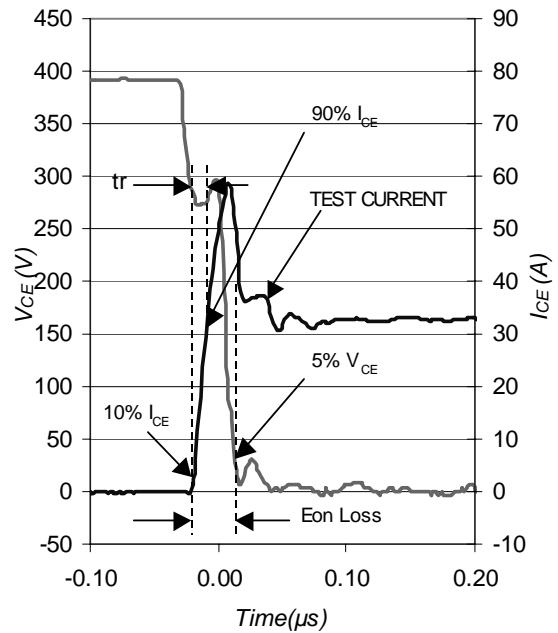
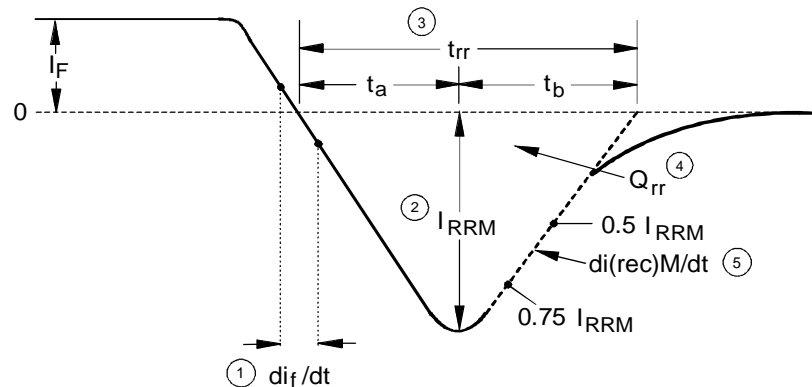

Fig. WF2 - Typ. Turn-on Loss Waveform
@ $T_J = 25^\circ\text{C}$ using Fig. CT.3



1. di_f/dt - Rate of change of current through zero crossing
2. I_{RRM} - Peak reverse recovery current
3. t_{rr} - Reverse recovery time measured from zero crossing point of negative going I_F to point where a line passing through $0.75 I_{RRM}$ and $0.50 I_{RRM}$ extrapolated to zero current

4. Q_{rr} - Area under curve defined by t_{rr} and I_{RRM}

$$Q_{rr} = \frac{t_{rr} \times I_{RRM}}{2}$$

5. $di_{(rec)M}/dt$ - Peak rate of change of current during t_b portion of t_{rr}

Fig. WF3 - Reverse Recovery Waveform and Definitions

TO-247AC Package Outline

Dimensions are shown in millimeters (inches)

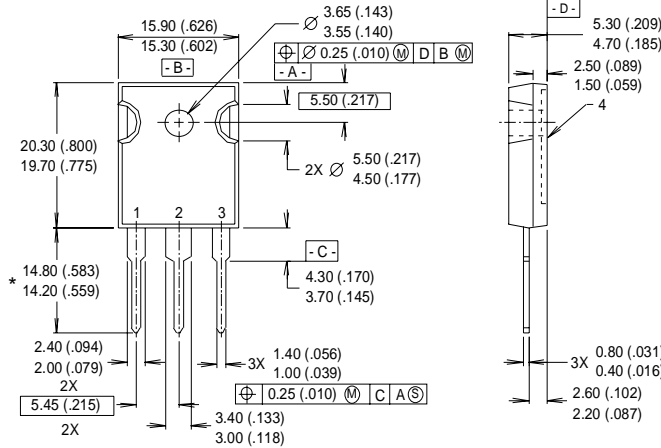

NOTES:

- 1 DIMENSIONS & TOLERANCING PER ANSI Y14.5M, 1982.
- 2 CONTROLLING DIMENSION : INCH.
- 3 DIMENSIONS ARE SHOWN MILLIMETERS (INCHES).
- 4 CONFORMS TO JEDEC OUTLINE TO-247AC.

LEAD ASSIGNMENTS

- 1 - GATE
- 2 - COLLECTOR
- 3 - EMITTER
- 4 - COLLECTOR

* LONGER LEADED (20mm) VERSION AVAILABLE (TO-247AD) TO ORDER ADD "E" SUFFIX TO PART NUMBER

CONFORMS TO JEDEC OUTLINE TO-247AC (TO-3P)
Dimensions in Millimeters and (Inches)

TO-247AC Part Marking Information

Notes: This part marking information applies to devices produced before 02/26/2001 or for parts manufactured in GB.

EXAMPLE: THIS IS AN IRFPE30 WITH ASSEMBLY LOT CODE 3A1Q

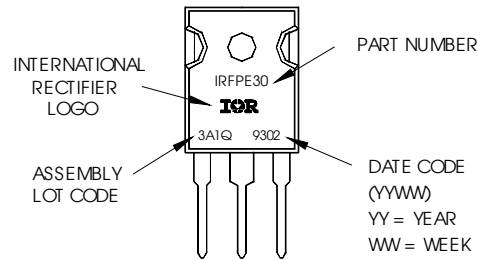

Notes: This part marking information applies to devices produced after 02/26/2001

EXAMPLE: THIS IS AN IRFPE30 WITH ASSEMBLY LOT CODE 5657 ASSEMBLED ON WW 35, 2000 IN THE ASSEMBLY LINE "H"

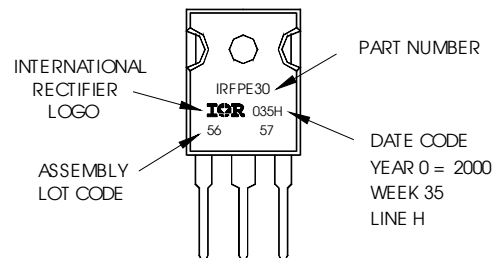

TO-247AC package is not recommended for Surface Mount Application.

Data and specifications subject to change without notice.
This product has been designed and qualified for Industrial market.
Qualification Standards can be found on IR's Web site.



LittleDiode supplies new, hard to find or obsolete electronic components and semiconductors all over the world.

With over two million different components listed you are sure to find the part you need.

Feel free to visit us today at our online store:

LittleDiode.com

Looking forward to providing you with the best possible service.