

HiPerFET™ Power MOSFET

IXFE 55N50
IXFE 50N50

Single Die MOSFET

Preliminary data sheet

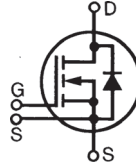

V_{DSS}	I_{D25}	$R_{DS(on)}$
500 V	50 A	90 mΩ
500 V	47 A	100 mΩ

$t_{rr} \leq 250$ ns

Symbol Test Conditions

Maximum Ratings

V_{DSS}	$T_J = 25^\circ\text{C}$ to 150°C	500	V
V_{DGR}	$T_J = 25^\circ\text{C}$ to 150°C , $R_{GS} = 1\text{M}\Omega$	500	V
V_{GS}	Continuous	± 20	V
V_{GSM}	Transient	± 30	V
I_{D25}	$T_C = 25^\circ\text{C}$	55N50: 47 50N50: 50	A
I_{DM}	$T_C = 25^\circ\text{C}$; Note 1	55N50: 200 50N50: 220	A
I_{AR}	$T_C = 25^\circ\text{C}$	55	A
E_{AR}	$T_C = 25^\circ\text{C}$	60	mJ
dv/dt	$I_S \leq I_{DM}$, $di/dt \leq 100$ A/ μs , $V_{DD} \leq V_{DSS}$ $T_J \leq 150^\circ\text{C}$, $R_G = 2 \Omega$	5	V/ns
P_D	$T_C = 25^\circ\text{C}$	500	W
T_J		-40 ... +150	$^\circ\text{C}$
T_{JM}		150	$^\circ\text{C}$
T_{stg}		-40 ... +150	$^\circ\text{C}$
V_{ISOL}	50/60 Hz, RMS $t = 1$ min $I_{ISOL} \leq 1$ mA $t = 1$ s	2500 3000	V~ V~
M_d	Mounting torque Terminal connection torque	1.5/13 Nm/lb.in. 1.5/13 Nm/lb.in.	
Weight		19	g

ISOPLUS 227™ (IXFE)

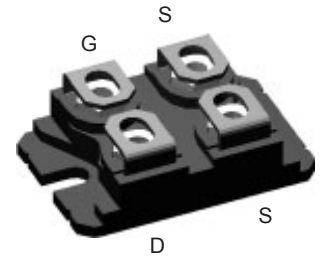

G = Gate
S = Source
D = Drain

Either Source terminal at miniBLOC can be used as Main or Kelvin Source

Features

- Low cost direct-copper bonded aluminium package
- Encapsulating epoxy meets UL 94 V-0, flammability classification
- 2500V isolation
- Low drain to case capacitance
- Low $R_{DS(on)}$ HDMOS™ process
- Rugged polysilicon gate cell structure
- Unclamped Inductive Switching (UIS) rated
- Low package inductance
- Fast intrinsic Rectifier
- Conforms to SOT-227B outline

Applications

- DC-DC converters
- Battery chargers
- Switched-mode and resonant-mode power supplies
- DC choppers
- Temperature and lighting controls

Advantages

- Easy to mount
- Space savings
- High power density

Symbol Test Conditions

($T_J = 25^\circ\text{C}$, unless otherwise specified)

Characteristic Values

		Min.	Typ.	Max.
V_{DSS}	$V_{GS} = 0$ V, $I_D = 1$ mA	500		V
$V_{GS(th)}$	$V_{DS} = V_{GS}$, $I_D = 8$ mA	2.5		4.5 V
I_{GSS}	$V_{GS} = \pm 20$ V, $V_{DS} = 0$ V			± 200 nA
I_{DSS}	$V_{DS} = V_{DSS}$ $V_{GS} = 0$ V		$T_J = 25^\circ\text{C}$ $T_J = 125^\circ\text{C}$	25 μA 2 mA
$R_{DS(on)}$	$V_{GS} = 10$ V, $I_D = I_T$ Note 2	55N50 50N50		90 mΩ 100 mΩ

Symbol	Test Conditions	Characteristic Values		
		Min.	Typ.	Max.
g_{fs}	$V_{DS} = 10\text{ V}; I_D = I_T$ Note 2		45	S
C_{iss}	$V_{GS} = 0\text{ V}, V_{DS} = 25\text{ V}, f = 1\text{ MHz}$		9400	pF
C_{oss}			1200	pF
C_{rss}			460	pF
$t_{d(on)}$ t_r $t_{d(off)}$ t_f	$V_{GS} = 10\text{ V}, V_{DS} = 0.5 \cdot V_{DSS}, I_D = I_T$ $R_G = 1\ \Omega$ (External),		45	ns
			60	ns
			120	ns
			45	ns
$Q_{g(on)}$ Q_{gs} Q_{gd}	$V_{GS} = 10\text{ V}, V_{DS} = 0.5 \cdot V_{DSS}, I_D = I_T$		330	nC
			55	nC
			185	nC
R_{thJC} R_{thCK}			0.25	K/W
			0.07	K/W

Source-Drain Diode

($T_J = 25^\circ\text{C}$, unless otherwise specified)

Symbol	Test Conditions	Characteristic Values			
		Min.	Typ.	Max.	
I_S	$V_{GS} = 0$	55N50 50N50		55 50	A A
I_{SM}	Repetitive; pulse width limited by T_{JM}	55N50 50N50		220 200	A A
V_{SD}	$I_F = I_S, V_{GS} = 0\text{ V}$, Note 2			1.5	V
t_{rr} Q_{RM} I_{RM}	$I_F = 25\text{ A}, -di/dt = 100\text{ A}/\mu\text{s}, V_R = 100\text{ V}$		1.0	250	ns μC
			10		A

- Notes:
1. Pulse width limited by T_{JM} .
 2. Pulse test, $t \leq 300\text{ ms}$, duty cycle $d \leq 2\%$.
 3. I_T Test current:
IXFE55N50: $I_T = 27.5\text{ A}$
IXFE50N50: $I_T = 25\text{ A}$

ISOPLUS-227 B

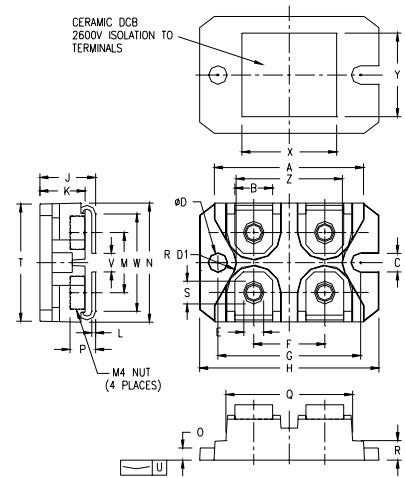

SYM	INCHES		MILLIMETERS	
	MIN	MAX	MIN	MAX
A	1.240	1.270	31.50	32.26
B	.310	.330	7.87	8.38
C	.155	.165	3.94	4.19
D	.155	.165	3.94	4.19
D1	.150	.157	3.81	3.98
E	.160	.168	4.06	4.27
F	.587	.595	14.91	15.11
G	1.186	1.193	30.12	30.30
H	1.489	1.505	37.80	38.23
J	.465	.481	11.81	12.22
K	.370	.380	9.40	9.65
L	.030	.033	0.76	0.84
M	.496	.506	12.60	12.85
N	.990	1.001	25.15	25.42
O	.100	.105	2.54	2.67
P	.195	.235	4.95	5.97
Q	1.045	1.059	26.54	26.90
R	.160	.170	4.06	4.32
S	.186	.191	4.72	4.85
T	.968	.987	24.59	25.07
U	-.001	.002	-0.03	0.05
V	.130	.160	3.30	4.06
W	.780	.830	19.81	21.08
X	.770	.810	19.56	20.57
Y	.680	.720	17.27	18.29
Z	.885	.892	22.48	22.66

Please see IXFN55N50 data sheet for characteristic curves.

IXYS reserves the right to change limits, test conditions, and dimensions.

IXYS MOSFETs and IGBTs are covered by one or more of the following U.S. patents:

4,835,592 4,881,106 5,017,508 5,049,961 5,187,117 5,486,715 6,306,728B1 6,259,123B1 6,306,728B1
4,850,072 4,931,844 5,034,796 5,063,307 5,237,481 5,381,025 6,404,065B1 6,162,665 6,534,343



LittleDiode supplies new, hard to find or obsolete electronic components and semiconductors all over the world.

With over two million different components listed you are sure to find the part you need.

Feel free to visit us today at our online store:

LittleDiode.com

Looking forward to providing you with the best possible service.