

DESCRIPTION

2SC908 is a silicon NPN epitaxial planar type transistor designed for industrial use RF power amplifiers on UHF band mobile radio applications.

FEATURES

- High power gain: $G_{pe} \geq 4\text{dB}$
@ $V_{CC} = 13.5\text{V}$, $P_O = 1\text{W}$, $f = 500\text{MHz}$
- TO-39 metal sealed package for high reliability.
- All electrodes are isolated from the case.

APPLICATION

0.5 to 0.8 watt power amplifiers, and driver stage in UHF band.

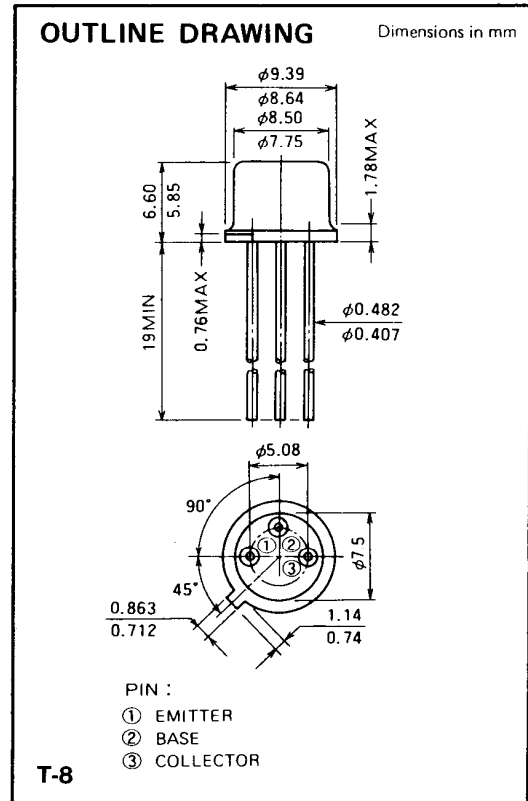

ABSOLUTE MAXIMUM RATINGS ($T_C = 25^\circ\text{C}$ unless otherwise specified)

Symbol	Parameter	Conditions	Ratings	Unit
V_{CBO}	Collector to base voltage		40	V
V_{EBO}	Emitter to base voltage		4	V
V_{CER}	Collector to emitter voltage	$R_{BE} = 10 \Omega$	40	V
I_C	Collector current		0.5	A
P_C	Collector dissipation	$T_a = 25^\circ\text{C}$	0.86	W
		$T_C = 25^\circ\text{C}$	4.3	W
T_j	Junction temperature		175	$^\circ\text{C}$
T_{stg}	Storage temperature		-65 to 175	$^\circ\text{C}$
R_{th-a}	Thermal resistance	Junction to ambient	175	$^\circ\text{C}/\text{W}$
R_{th-c}		Junction to case	35	$^\circ\text{C}/\text{W}$

Note. Above parameters are guaranteed independently.

ELECTRICAL CHARACTERISTICS ($T_C = 25^\circ\text{C}$ unless otherwise specified)

Symbol	Parameter	Test conditions	Limits			Unit
			Min	Typ	Max	
$V_{(BR)EBO}$	Emitter to base breakdown voltage	$I_E = 1\text{mA}$, $I_C = 0$	4			V
$V_{(BR)CBO}$	Collector to base breakdown voltage	$I_C = 10\text{mA}$, $I_E = 0$	40			V
$V_{(BR)CER}$	Collector to emitter breakdown voltage	$I_C = 10\text{mA}$, $R_{BE} = 10 \Omega$	40			V
I_{CBO}	Collector cutoff current	$V_{CB} = 15\text{V}$, $I_E = 0$			50	μA
I_{EBO}	Emitter cutoff current	$V_{EB} = 3\text{V}$, $I_C = 0$			100	μA
h_{FE}	DC forward current gain*	$V_{CE} = 10\text{V}$, $I_C = 0.1\text{A}$	10	50	180	—
P_O	Output power	$V_{CC} = 13.5\text{V}$, $P_{in} = 0.4\text{W}$, $f = 500\text{MHz}$	1	1.2		W
η_C	Collector efficiency		50	70		%

Note. * Pulse test, $P_W = 150\mu\text{s}$, duty = 5%.

Above parameters, ratings, limits and conditions are subject to change.

TEST CIRCUIT

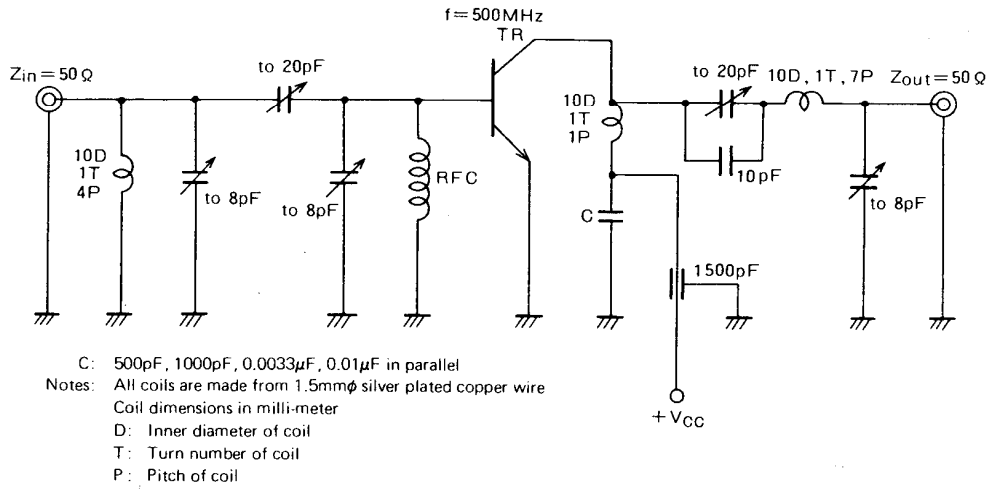

TYPICAL PERFORMANCE DATA

COLLECTOR DISSIPATION VS. AMBIENT TEMPERATURE

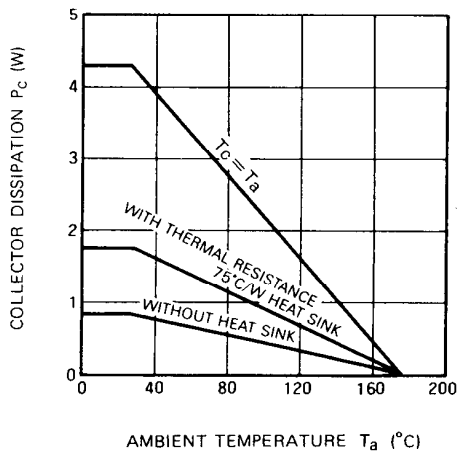

THERMAL RESISTANCE 75°C HEAT SINK DRAWING

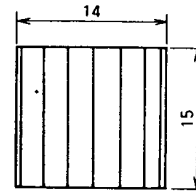
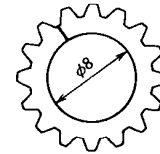

MATERIAL: Al
DIMENSIONS: mm

COLLECTOR CURRENT VS. COLLECTOR TO EMITTER VOLTAGE

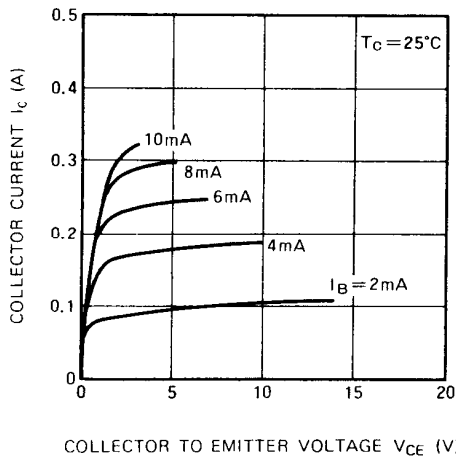

COLLECTOR TO EMITTER BREAKDOWN VOLTAGE VS. BASE TO EMITTER RESISTANCE

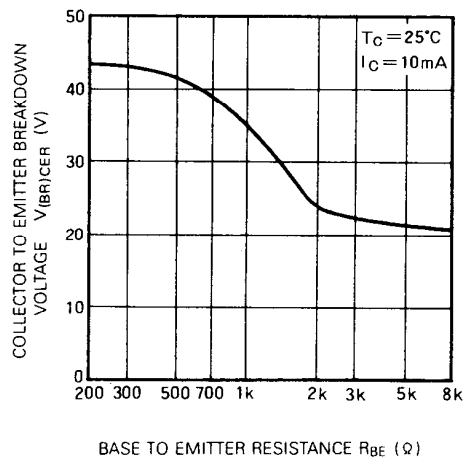

DC CURRENT GAIN VS. COLLECTOR CURRENT

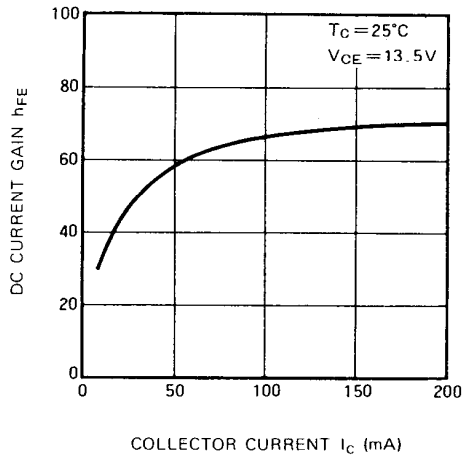

COLLECTOR OUTPUT CAPACITANCE VS. COLLECTOR TO BASE VOLTAGE

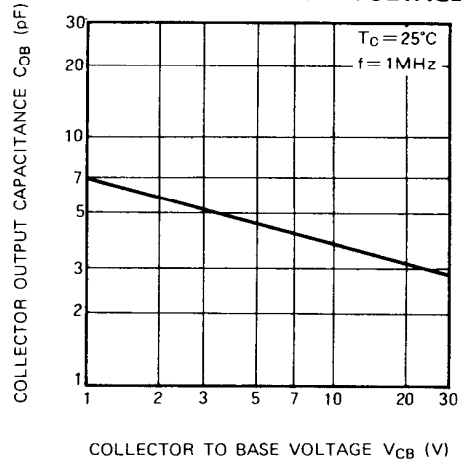

OUTPUT POWER VS. COLLECTOR SUPPLY VOLTAGE

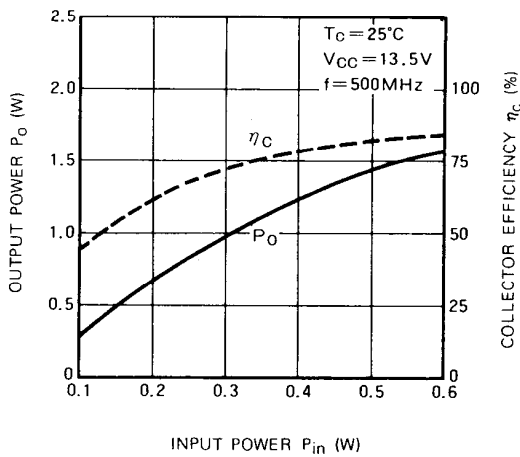

OUTPUT POWER, COLLECTOR EFFICIENCY VS. INPUT POWER

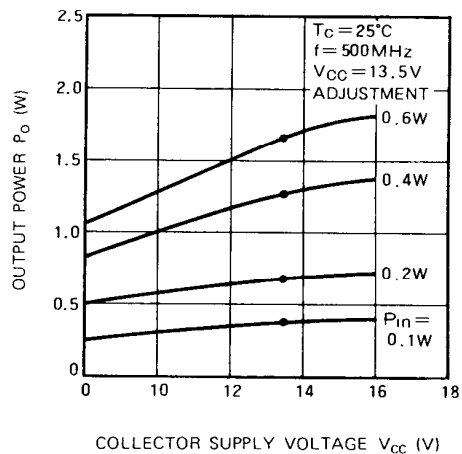

OUTPUT POWER VS. FREQUENCY

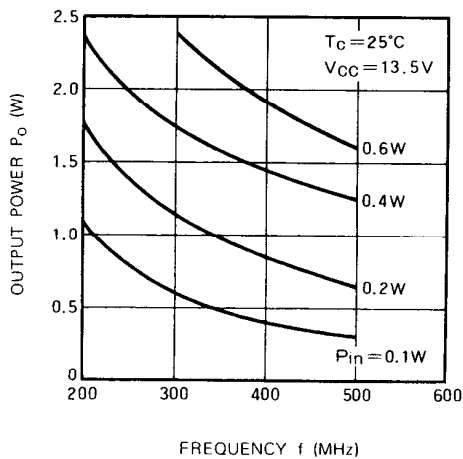



LittleDiode supplies new, hard to find or obsolete electronic components and semiconductors all over the world.

With over two million different components listed you are sure to find the part you need.

Feel free to visit us today at our online store:

LittleDiode.com

Looking forward to providing you with the best possible service.